

Name: _____	Date: _____ Event: _____
City: _____ State: _____	Track: _____

Track  Indoor  Tight  Smooth  Hard Packed  Blue Groove  Wet  Low Bite  High Bite  
 Conditions  Outdoor  Open  Rough  Loose/Loamy  Dry  Dusty  Med Bite  Other \_\_\_\_\_

**Front Suspension**

Toe: \_\_\_\_\_  
 Ride Height: \_\_\_\_\_  
 Camber: \_\_\_\_\_  
 Caster: \_\_\_\_\_  
 Spindle Height:  High  Low  
 Wheel Hex: \_\_\_\_\_  
 Sway Bar: \_\_\_\_\_  
 Piston/Oil: \_\_\_\_\_  
 Shock Type:  Bladder  Emulsion  
 Spring: \_\_\_\_\_  
 Limiter/Droop: \_\_\_\_\_  
 Overall Shock Length: \_\_\_\_\_  
 Steering Ackerman: \_\_\_\_\_  
 Bump Steer: \_\_\_\_\_  
 Camber Link: \_\_\_\_\_  
 Shock Location: \_\_\_\_\_  
 Receiver Battery Type: \_\_\_\_\_

**Differentials**

Front:  Standard  Smart  
 Spring Wire Dia. \_\_\_\_\_  
 Qty of Springs: \_\_\_\_\_  
 Ramp Plate: \_\_\_\_\_  
 Grease: \_\_\_\_\_  
 Diff Fluid: \_\_\_\_\_

Center:  Standard  Smart  
 Spring Wire Dia.: \_\_\_\_\_  
 Qty of Springs: \_\_\_\_\_  
 Ramp Plate: \_\_\_\_\_  
 Grease: \_\_\_\_\_  
 Diff Fluid: \_\_\_\_\_

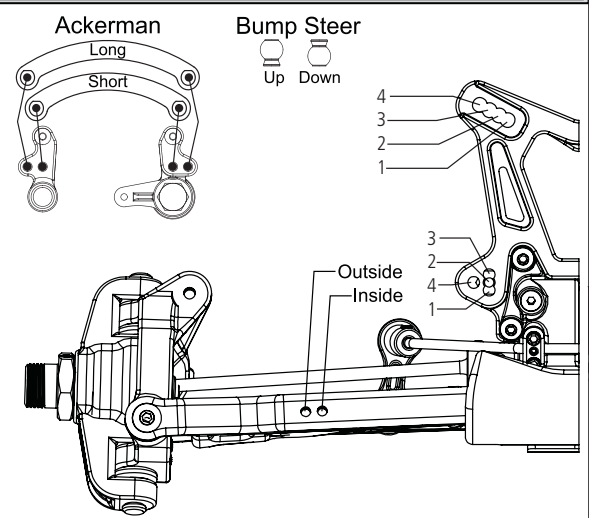

Notes: \_\_\_\_\_  
 \_\_\_\_\_  
 \_\_\_\_\_

**Rear Suspension**

Roll Center:  HRC  LRC  
 Toe: \_\_\_\_\_  
 Anti-Squat: \_\_\_\_\_  
 Ride Height: \_\_\_\_\_  
 Camber: \_\_\_\_\_  
 Rear Hub Spacing: \_\_\_\_\_  
 Wheel Hex: \_\_\_\_\_  
 Sway Bar: \_\_\_\_\_  
 Piston/Oil: \_\_\_\_\_  
 Shock Type:  Bladder  Emulsion  
 Spring: \_\_\_\_\_  
 Limiter/Droop: \_\_\_\_\_  
 Overall Shock Length: \_\_\_\_\_  
 Camber Link: \_\_\_\_\_  
 Shock Position: \_\_\_\_\_  
 Rear Diff Fluid: \_\_\_\_\_

**Wing Setup**

Wing Type:  2.0  3.0  
 Wing Spacer:  .250  .500  
 Wicker Bill:  .250  .350

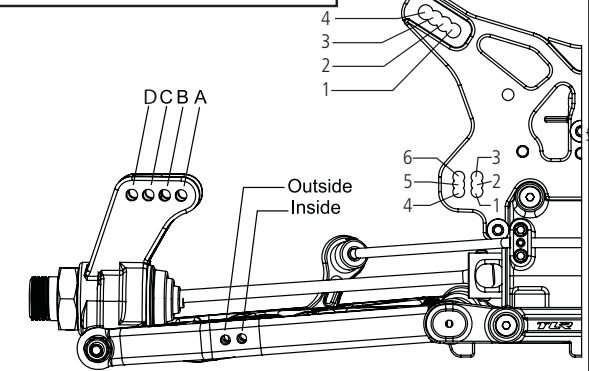

Notes: \_\_\_\_\_  
 \_\_\_\_\_  
 \_\_\_\_\_

**Engine**

Engine: \_\_\_\_\_ Fuel: \_\_\_\_\_  
 Glow Plug: \_\_\_\_\_ Head Clearance \_\_\_\_\_  
 Pipe/Header: \_\_\_\_\_ Gearing: \_\_\_\_\_

**Clutch**

Clutch Shoes and Springs Info

\_\_\_\_\_

\_\_\_\_\_

\_\_\_\_\_

**Tires**

Type	Compound	Insert
Front: _____	_____	_____
Rear: _____	_____	_____
Notes: _____		
_____		