

Name: _____		Date: _____		Event: _____	
City: _____		State: _____		Track: _____	
Track Conditions: <input type="checkbox"/> Indoor <input type="checkbox"/> Tight <input type="checkbox"/> Smooth <input type="checkbox"/> Hard Packed <input type="checkbox"/> Blue Groove <input type="checkbox"/> Wet <input type="checkbox"/> Low Bite <input type="checkbox"/> High Bite <input type="checkbox"/> Outdoor <input type="checkbox"/> Open <input type="checkbox"/> Rough <input type="checkbox"/> Loose/Loamy <input type="checkbox"/> Dry <input type="checkbox"/> Dusty <input type="checkbox"/> Med Bite <input type="checkbox"/> Other _____					

**Front Suspension**

Toe: \_\_\_\_\_  
 Ride Height: \_\_\_\_\_  
 Camber: \_\_\_\_\_  
 Caster: \_\_\_\_\_  
 Spindle Height:  High  Low  
 Wheel Hex: \_\_\_\_\_  
 Sway Bar: \_\_\_\_\_  
 Piston/Oil: \_\_\_\_\_  
 Shock Type:  Bladder  Emulsion  
 Spring: \_\_\_\_\_  
 Limiter/Droop: \_\_\_\_\_  
 Overall Shock Length: \_\_\_\_\_  
 Steering Ackerman: \_\_\_\_\_  
 Bump Steer: \_\_\_\_\_  
 Camber Link: \_\_\_\_\_  
 Shock Location: \_\_\_\_\_  
 Receiver Battery Type: \_\_\_\_\_

**Differentials**

Front:  Standard  Smart  
 Spring Wire Dia.: \_\_\_\_\_  
 Qty of Springs: \_\_\_\_\_  
 Ramp Plate: \_\_\_\_\_  
 Grease: \_\_\_\_\_  
 Diff Fluid: \_\_\_\_\_  
 Center:  Standard  Smart  
 Spring Wire Dia.: \_\_\_\_\_  
 Qty of Springs: \_\_\_\_\_  
 Ramp Plate: \_\_\_\_\_  
 Grease: \_\_\_\_\_  
 Diff Fluid: \_\_\_\_\_

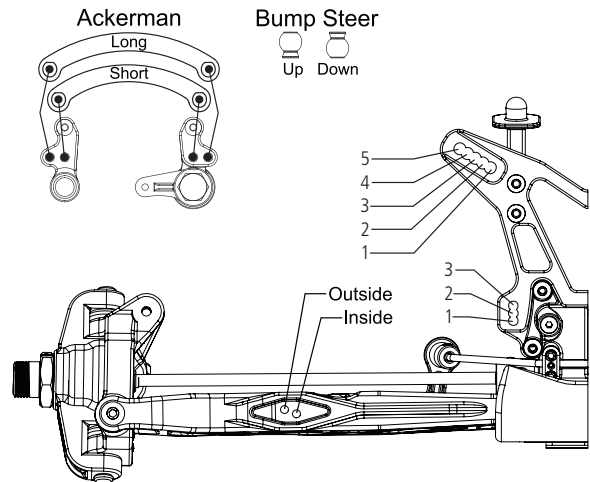

Notes: \_\_\_\_\_  
 \_\_\_\_\_  
 \_\_\_\_\_

**Rear Suspension**

Roll Center:  HRC  LRC  
 Toe: \_\_\_\_\_  
 Anti-Squat: \_\_\_\_\_  
 Ride Height: \_\_\_\_\_  
 Camber: \_\_\_\_\_  
 Rear Hub Spacing: \_\_\_\_\_  
 Wheel Hex: \_\_\_\_\_  
 Sway Bar: \_\_\_\_\_  
 Piston/Oil: \_\_\_\_\_  
 Shock Type:  Bladder  Emulsion  
 Spring: \_\_\_\_\_  
 Limiter/Droop: \_\_\_\_\_  
 Overall Shock Length: \_\_\_\_\_  
 Camber Link: \_\_\_\_\_  
 Shock Position: \_\_\_\_\_  
 Rear Diff Fluid: \_\_\_\_\_

**Wing Setup**

Wing Type:  2.0  3.0  
 Wing Spacer:  .250  .500  
 Wicker Bill:  .250  .350

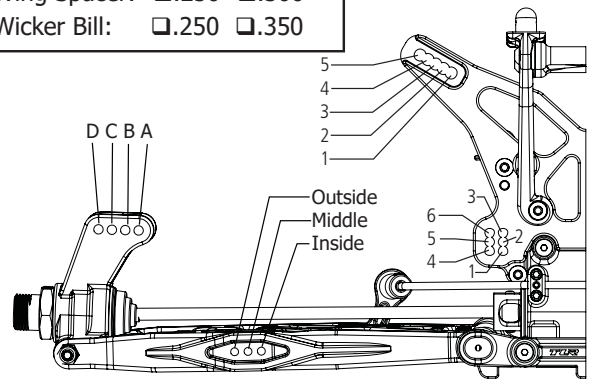

Notes: \_\_\_\_\_  
 \_\_\_\_\_  
 \_\_\_\_\_

**Engine**

Engine: \_\_\_\_\_ Fuel: \_\_\_\_\_  
 Glow Plug: \_\_\_\_\_ Head Clearance \_\_\_\_\_  
 Pipe/Header: \_\_\_\_\_ Gearing: \_\_\_\_\_

**Clutch**

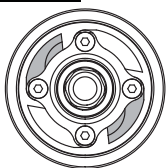

Clutch Shoes and Springs Info

\_\_\_\_\_  
 \_\_\_\_\_  
 \_\_\_\_\_

**Tires**

Type Compound Insert

Front: \_\_\_\_\_  
 Rear: \_\_\_\_\_  
 Notes: \_\_\_\_\_