

BLADE[®]
#1 BY DESIGN

360CFX
BS



Instruction Manual
Bedienungsanleitung
Manuel d'utilisation
Manuale di Istruzioni

BNF[®]
BASIC

AS3X[®] 

NOTICE

All instructions, warranties and other collateral documents are subject to change at the sole discretion of Horizon Hobby, LLC. For up-to-date product literature, visit horizonhobby.com and click on the support tab for this product.

Meaning of Special Language

The following terms are used throughout the product literature to indicate various levels of potential harm when operating this product:

NOTICE: Procedures, which if not properly followed, create a possibility of physical property damage AND a little or no possibility of injury.

CAUTION: Procedures, which if not properly followed, create the probability of physical property damage AND a possibility of serious injury.

WARNING: Procedures, which if not properly followed, create the probability of property damage, collateral damage, and serious injury OR create a high probability of superficial injury.

 **WARNING:** Read the ENTIRE instruction manual to become familiar with the features of the product before operating. Failure to operate the product correctly can result in damage to the product, personal property and cause serious injury.

This is a sophisticated hobby product. It must be operated with caution and common sense and requires some basic mechanical ability. Failure to operate this Product in a safe and responsible manner could result in injury or damage to the product or other property. This product is not intended for use by children without direct adult supervision. Do not use with incompatible components or alter this product in any way outside of the instructions provided by Horizon Hobby, LLC. This manual contains instructions for safety, operation and maintenance. It is essential to read and follow all the instructions and warnings in the manual, prior to assembly, setup or use, in order to operate correctly and avoid damage or serious injury.

Age Recommendation: Not for children under 14 years. This is not a toy.

Safety Precautions and Warnings

- Always keep a safe distance in all directions around your model to avoid collisions or injury. This model is controlled by a radio signal subject to interference from many sources outside your control. Interference can cause momentary loss of control.
- Always operate your model in open spaces away from full-size vehicles, traffic and people.
- Always carefully follow the directions and warnings for this and any optional support equipment (chargers, rechargeable battery packs, etc.).
- Always keep all chemicals, small parts and anything electrical out of the reach of children.
- Always avoid water exposure to all equipment not specifically designed and protected for this purpose. Moisture causes damage to electronics.
- Never place any portion of the model in your mouth as it could cause serious injury or even death.
- Never operate your model with low transmitter batteries.
- Always keep aircraft in sight and under control.
- Always move the throttle fully down at rotor strike.
- Always use fully charged batteries.
- Always keep transmitter powered on while aircraft is powered.
- Always remove batteries before disassembly.
- Always keep moving parts clean.
- Always keep parts dry.
- Always let parts cool after use before touching.
- Always remove batteries after use.
- Never operate aircraft with damaged wiring.
- Never touch moving parts.

 **WARNING AGAINST COUNTERFEIT PRODUCTS:** If you ever need to replace a Spektrum component found in a Horizon Hobby product, always purchase from Horizon Hobby, LLC or a Horizon Hobby authorized dealer to ensure authentic high-quality Spektrum product. Horizon Hobby, LLC disclaims all support and warranty with regards, but not limited to, compatibility and performance of counterfeit products or products claiming compatibility with DSM or Spektrum technology.

As of this printing, you are required to register with the FAA if you own this product. For up-to-date information on how to register with the FAA, please visit <https://registermyuas.faa.gov/>. For additional assistance on regulations and guidance on UAS usage, visit knowbeforeyoufly.org/.

Box Contents:

- Blade 360 CFX 3S

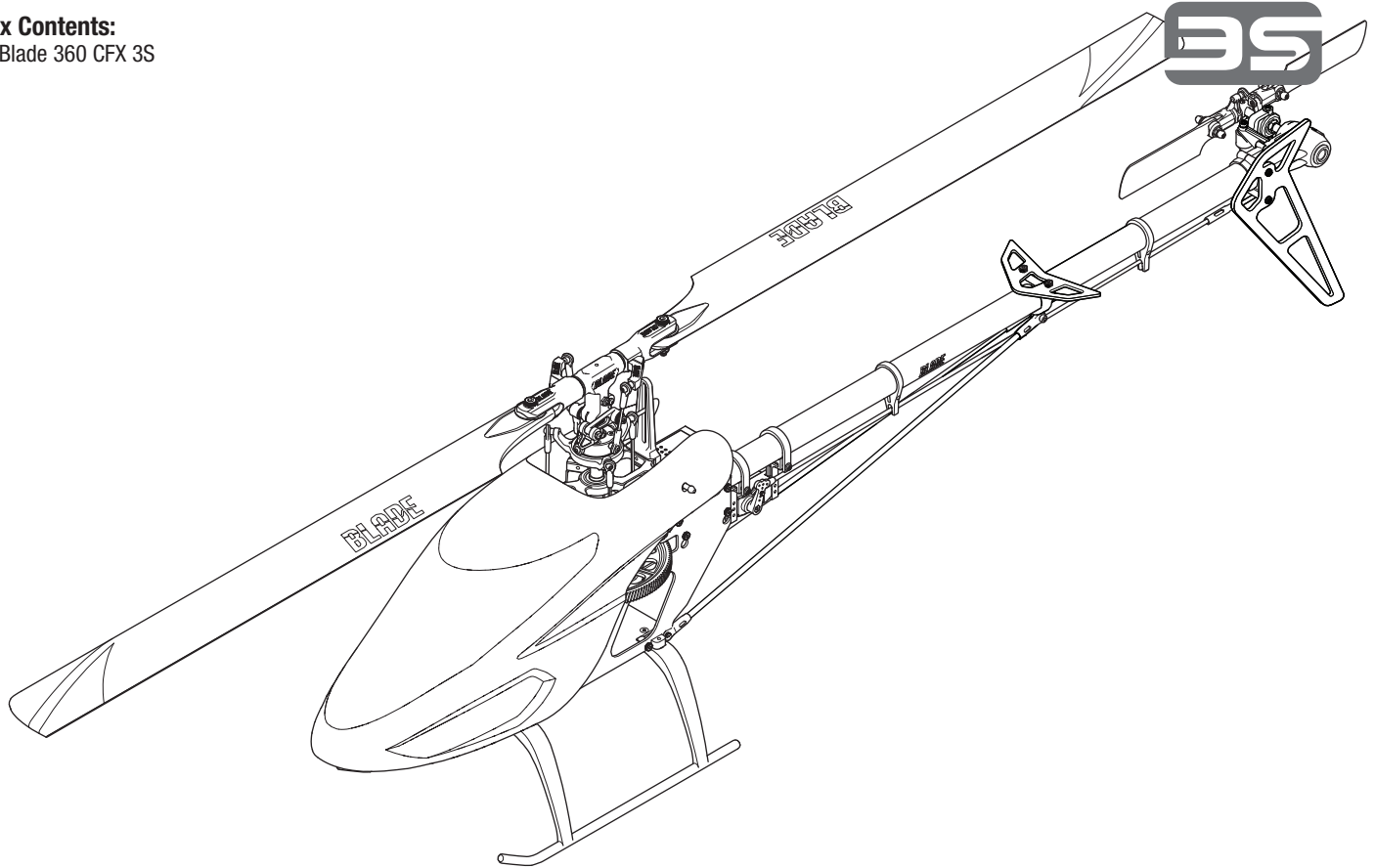

Table of Contents

First Flight Preparation	4	Blade Helicopter Belt Tension	8
Flying Checklist	4	Post-Flight Inspections and Maintenance	9
Low Voltage Cutoff (LVC)	4	Troubleshooting Guide	12
Transmitter Setup	4	Limited Warranty	12
Installing the Flight Battery	6	Warranty and Service Contact Information	13
Transmitter and Receiver Binding.....	6	Compliance Information for the European Union.....	13
Throttle Hold	6	FCC Information.....	13
Control Tests.....	7	IC Information	13
Pre-Flight Checklist	8	Exploded Views.....	50
Flying the Blade 360 CFX 3S	8	Parts List	52
Gyro Gain Adjustment	8	Optional Parts	53

Specifications

Length	26.4 in (670mm)	Tail Rotor Diameter	6.9 in (175mm)
Height	8.5 in (215mm)	Flying Weight	30 oz (850 g)
Main Rotor Diameter	31.89 in (810mm)		

Included Components

Airframe	Blade® 360 CFX 3S
Motor	Brushless Outrunner, 3400 Kv
Receiver	Spektrum™ AR636A AS3X®
ESC	45-Amp Brushless ESC
Swash Servos	Digital Cyclic Servo 12 g Metal Gear
Tail Servo	Digital Tail Servo 12 g Metal Gear

Required Components

Battery	3000 mAh 3S 11.1V 30C LiPo (EFLB30003S30)
Charger	Li-Po Balancing Charger
Transmitter	Full Range DSM2®/DSMX® technology transmitter (DXe and up)

To receive product updates, special offers and more, register your product at www.bladehelis.com

First Flight Preparation

- Remove and inspect contents
- Charge the flight battery
- Install the flight battery in the helicopter (once it has been fully charged)
- Program your computer transmitter
- Bind your transmitter
- Familiarize yourself with the controls
- Find a suitable area for flying

Flying Checklist

- Always turn the transmitter on first
- Turn throttle hold On
- Plug the flight battery into the lead from the ESC
- Allow the ESC to initialize and arm properly
- Perform control test
- Place the model onto flat ground at least 10 meters from the pilot. Ensure the area is free from obstructions
- Fly the model
- Land the model
- Unplug the flight battery from the ESC
- Always turn the transmitter off last

Low Voltage Cutoff (LVC)

The ESC will continuously lower power to the motor until complete shutdown when the battery reaches 9V under load. This helps prevent over-discharge of the Li-Po battery. Land immediately when the ESC activates LVC. Continuing to fly after LVC can damage the battery, cause a crash or both. Crash damage and batteries damaged due to over-discharge are not covered under warranty.

Repeatedly flying the helicopter until LVC activates will damage the helicopter battery.

Disconnect and remove the Li-Po battery from the aircraft after use to prevent trickle discharge. During storage, make sure the battery charge does not fall below 3V per cell.

Electronic Speed Controller Governor Operation

The Blade 360 CFX 3S Electronic Speed Controller (ESC) utilizes a head speed governor to maintain a constant head speed during flight. The governor will work to maintain a constant head speed throughout maneuvers and the discharge cycle of the flight battery.

The default throttle curve settings listed in the transmitter setup tables should be acceptable to most pilots and we recommend starting with these values. If you feel an adjustment is necessary after a few flights, adjust the throttle percentage for the desired flight mode. We recommend making small changes of 5% to find your preferred head speed.

The throttle position determines the requested head speed, and although throttle curves are still used, they will be a constant value; all positions of the curve are set to the same value. The lowest position of the normal flight mode throttle curve must be set to 0 to ensure the motor can be disabled.

Remember the throttle position on the transmitter is simply requesting a specific head speed and this is not related to the actual motor power percentage.

Transmitter Setup

Program your transmitter before attempting to bind or fly the helicopter. Always start by creating a new model in the transmitter to ensure no existing settings are inadvertently used. Transmitter programming values are shown below for the

Spektrum Transmitters. The files for models using Spektrum™ transmitters with Spektrum AirWare™ software are also available for download online at www.spektrumrc.com.

DXe

To use the Spektrum™ DXe transmitter, download the Blade® 360 CFX 3S DXe model setup available at www.spektrumrc.com or use the appropriate programming cable and the PC or mobile app to program the transmitter.

DX6i

SETUP LIST		ADJUST LIST					
Model Type	HELI	TRAVEL ADJ		D/R & Expo			
Swash Type	1 servo 90	Channel	Travel	Chan	Sw Pos	D/R	Expo
REVERSE		THRO	100/100	AILE	0	100	0
Channel	Direction	AILE	100/100	ELEV	1	85	0
THRO	N	ELEV	100/100	ELEV	0	100	0
AILE	N	RUDD	100/100	ELEV	1	85	0
ELEV	N	GYRO	100/100	RUDD	0	100	0
RUDD	N	PITC	100/100	RUDD	1	85	0
GYRO	N	Throttle Curve					
PITC	R	Switch Pos (F Mode)	Pos 1	Pos 2	Pos 3	Pos 4	Pos 5
Modulation Type		NORM	0	50	50	50	50
AUTO DSMX-ENABLE		STUNT*	65	65	65	65	65
D/R COMBI		GYRO					
D/R SW	AILE	RATE	SW-F.MODE				
Timer		0	60%	NORM	0		
Down Timer	4:00	1	50%	STUNT	1		
Switch	THR CUT	Pitch Curve					
		Switch Pos (F Mode)	Pos 1	Pos 2	Pos 3	Pos 4	Pos 5
		NORM	25	37	50	75	100
		STUNT	0	25	50	75	100
		HOLD	25	37	50	75	100

SYSTEM SETUP

Model Type	HELI
Swash Type	1 servo 90
F-Mode Setup	
Flight Mode	F Mode
Hold	Hold
SW Select	
Trainer	Aux 2
F Mode	Gear
Gyro	INH
Mix	INH
Hold	INH
Knob	INH
Frame Rate	
	11ms
	DSMX

FUNCTION LIST

Servo Setup						Timer			
Chan	Travel	Reverse	Chan	Travel	Reverse	Mode	Count Down		
THR	100/100	Normal	GER	100/100	Normal	Time	4:00 Tone		
AIL	100/100	Normal	PIT	100/100	Normal	Start	Throttle Out		
ELE	100/100	Normal	AX2	100/100	Normal	Over	25%		
RUD	100/100	Normal							
D/R & Expo						Throttle Curve			
Chan	Switch Pos (Ail D/R)	D/R	Expo	Switch Pos (F Mode)	Pt 1	Pt 2	Pt 3	Pt 4	Pt 5
AILE	0	100/100	0	N	0	50	50	50	50
	1	85/85	0	1	55	55	55	55	55
	2	85/85	0	2	65	65	65	65	65
ELEV	0	100/100	0	Pitch Curve					
	1	85/85	0	Switch Pos (F Mode)	Pt 1	Pt 2	Pt 3	Pt 4	Pt 5
	2	85/85	0	N	25	37	50	75	100
RUDD	0	100/100	0	1	0	25	50	75	100
	1	85/85	0	2	0	25	50	75	100
	2	85/85	0	HOLD	25	37	50	75	100
Throttle Hold									
Throttle			0%						

DX6G2, DX6e, DX7G2, DX8G2, DX9, DX18, DX20

SYSTEM SETUP

Model Type	HELI
Swash Type	Normal
F-Mode Setup	
Switch 1	Switch B
Switch 2	Inhibit
Hold Switch	Switch H
	0 1
Channel Assign	
Channel Input Config	
1 Throttle	
2 Aileron	
3 Elevator	
4 Rudder	
5 Gear	Switch B
6 Collective	
7 AUX 2*	Switch I
Frame Rate	
	11ms*
	DSMX

FUNCTION LIST

Servo Setup						Timer								
Chan	Travel	Reverse	Chan	Travel	Reverse	Mode	Count Down							
THR	100/100	Normal	PIT	100/100	Normal	Time	4:00							
AIL	100/100	Normal	AX2*	100/100	Normal	Start	Throttle Out							
ELE	100/100	Normal	AX3*	100/100	Normal	Over	25%							
RUD	100/100	Normal	AX4*	100/100	Normal	One Time	Inhibit							
GER	100/100	Normal												
D/R & Expo						Throttle Curve								
Chan	Sw (F) Pos	D/R	Expo	Sw (B) Pos	Pt 1	Pt 2	Pt 3	Pt 4	Pt 5					
AILE	0	100/100	0	N	0	50	50	50	50					
	1	85/85	0	1	55	55	55	55	55					
	2	85/85	0	2	65	65	65	65	65					
ELEV	0	100/100	0	Hold	0	0	0	0	0					
	1	85/85	0	Pitch Curve										
	2	85/85	0	Sw (B) Pos	Pt 1	Pt 2	Pt 3	Pt 4	Pt 5					
Rudd	0	100/100	0	N	25	37	50	75	100					
	1	85/85	0	1	0	25	50	75	100					
	2	85/85	0	2	0	25	50	75	100					
Gyro						HOLD				25	37	50	75	100
Normal		85.0%												
Stunt 1		80.0%												
Stunt 2		75.0%												
Hold		85.0%												
Channel		Gear												
Switch		Flight Mode												

* Function is not available on all transmitters

Installing the Flight Battery

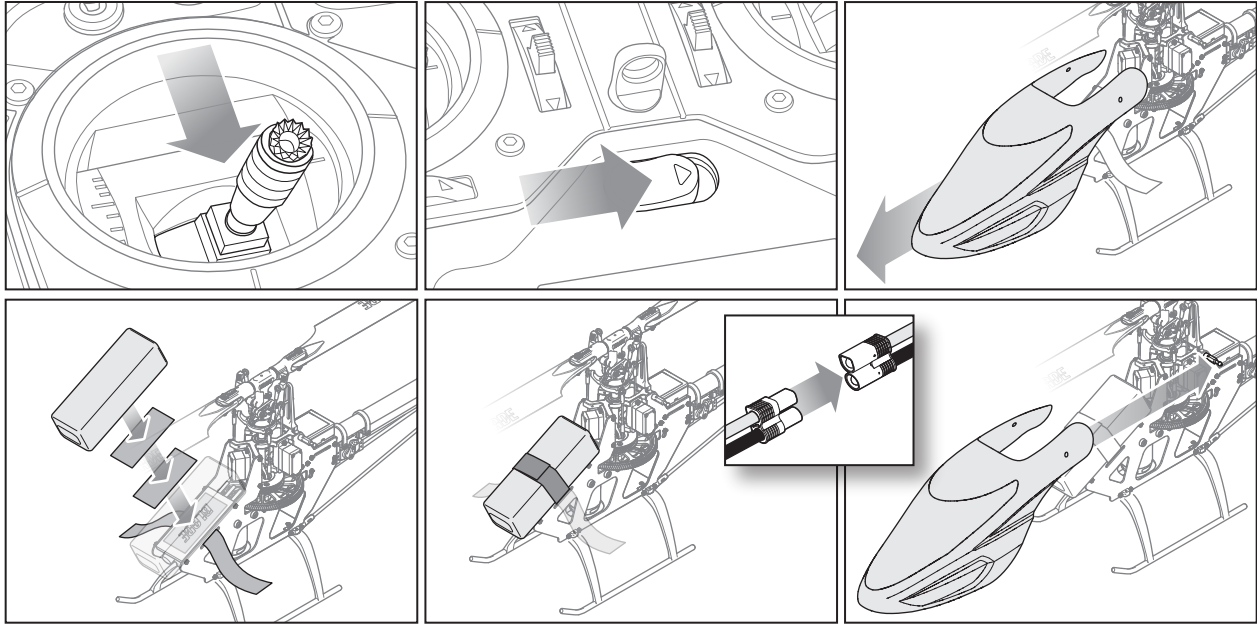

1. Lower the throttle.
2. Power on the transmitter.
3. Center the throttle trim.
4. To allow the ESC to arm and to keep rotors from initiating at startup, turn on throttle hold and normal flight mode before connecting the flight battery.
5. Attach hook material to the helicopter frame and loop material to the battery.
6. Install the flight battery on the helicopter frame. Secure the flight battery with a hook and loop strap. Connect the battery cable to the ESC.

7. Do not move the helicopter until the AR636A initializes. The swashplate will center, indicating that the unit is ready. The AR636A will also emit a solid orange Status LED when it is ready.
8. The helicopter motor will emit 2 ascending tones, indicating the ESC is armed.

CAUTION: Always disconnect the Li-Po battery from the ESC power lead when not flying to avoid over-discharging the battery. Batteries discharged to a voltage lower than the lowest approved voltage may become damaged, resulting in loss of performance and potential fire when batteries are charged.

Transmitter and Receiver Binding

Binding is the process of programming the receiver to recognize the GUID (Globally Unique Identifier) code of a single specific transmitter. You need to 'bind' your

chosen Spektrum™ DSM2/DSMX technology equipped aircraft transmitter to the receiver for proper operation.

Binding Procedure

1. Program your transmitter using the Transmitter Setup found in this manual.
2. Insert the bind plug in the BND/DAT port on the receiver.
3. Connect the flight battery to the ESC. The orange LED on the AR636 will begin flashing rapidly to indicate bind mode.
4. Move the throttle stick to the low throttle position in normal mode.
5. Follow the procedures of your specific transmitter to enter Bind Mode. The system will connect within a few seconds. Once connected, the orange LED will turn off and the AR636A will start the initialization process.
6. When the initialization process is complete, the Status LED light will come on solid orange.
7. Disconnect the flight battery and remove the bind plug from the AR636A. Store the bind plug in a convenient place.

WARNING: You must move the throttle to the LOW/OFF position during binding. Failure to do so may cause the rotor blades to spin and the helicopter to lift during the AR636A initialization, which could result in damage to property and injury.

NOTICE: Remove the bind plug to prevent the system from entering bind mode the next time the power is turned on.

CAUTION: When using a Futaba® transmitter with a Spektrum™ DSM2® module, you must reverse the throttle channel

If you encounter problems, obey binding instructions and refer to transmitter troubleshooting guide for other instructions. If needed, contact the appropriate Horizon Product Support office.

Throttle Hold

Throttle hold only turns off the motor on an electric helicopter. You maintain pitch and direction control.

The blades will spin if throttle hold is OFF. For safety, turn throttle hold ON any time you need to touch the helicopter or check the direction controls.

Throttle hold is also used to turn off the motor if the helicopter is out of control, in danger of crashing, or both.

Control Tests

CAUTION: You must complete the Tail Rotor and Cyclic tests prior to every flight. Failure to complete the tests and ensuring the sensor corrects in the proper direction can cause the helicopter to crash, resulting in property damage and injury.

Tail Rotor

1. Power on the transmitter.
2. Turn TH HOLD ON and put transmitter in normal mode.
3. Connect the flight battery to the ESC.

NOTICE: Do not allow the helicopter to move until the Status LED is solid orange. The AR636A will not operate correctly if the helicopter moves before the Status LED is solid orange.

4. Move the rudder stick to the right. The pitch slider on the tail shaft should move toward the tail case. If the pitch slider moves in the opposite direction, ensure the rudder channel reverse setting within the transmitter is set to normal.
5. Release the rudder control. Manually turn the helicopter nose to the left. The flight controller should compensate by moving the tail slider towards the tail case.

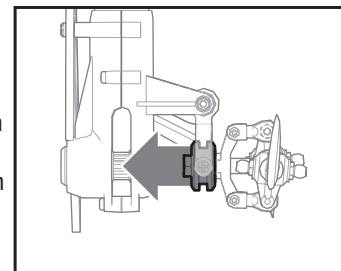

Cyclic

When using a flybarless flight controller, you are controlling rotational rates while the AR636A controls the servos. You are not directly controlling the servos with the transmitter.

It is normal for the swashplate to slowly move back to its original position after a stick input and for the servos to not move at the same speed as your control sticks.

1. Tilt the helicopter forward. The swashplate must tilt backward.
2. Tilt the helicopter backward. The swashplate must tilt forward.
3. Roll the helicopter left. The swashplate must roll right.
4. Roll the helicopter right. The swashplate must roll left.

Cyclic and Collective Control Test

Ensure the throttle hold is ON when performing the direction control tests.

Test the controls prior to each flight to ensure the servos, linkages and parts operate correctly. If the controls do not react as shown in the illustrations below,

confirm the transmitter is programmed correctly before continuing on to the Motor test.

Elevator

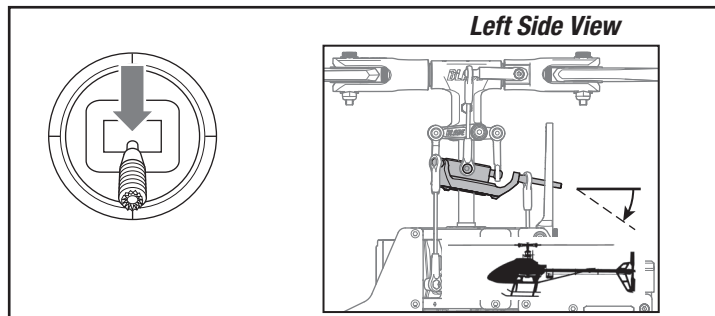
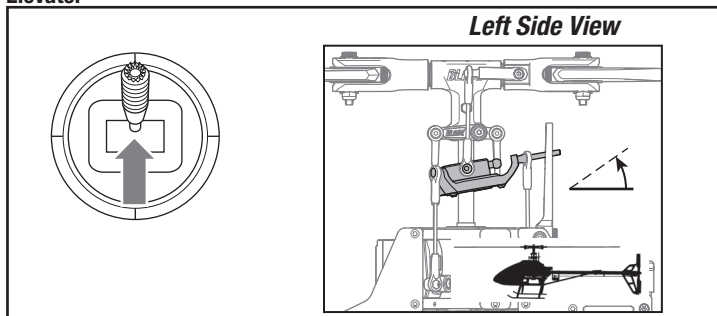

Aileron

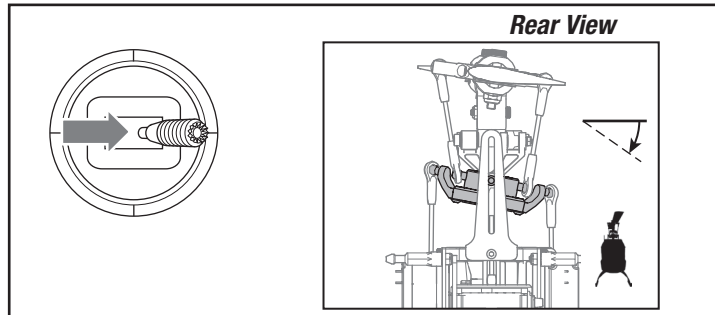
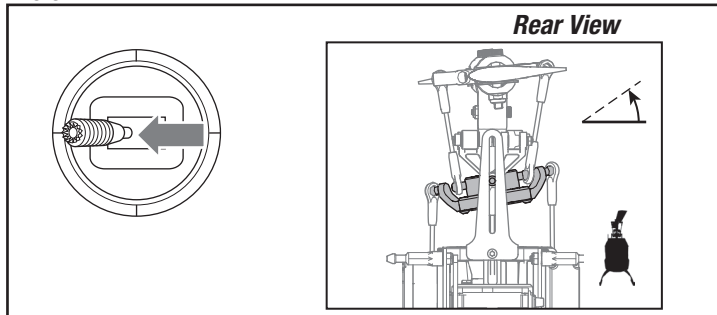

Collective Pitch

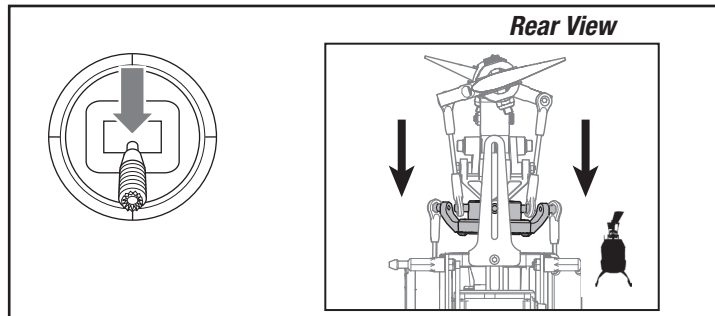
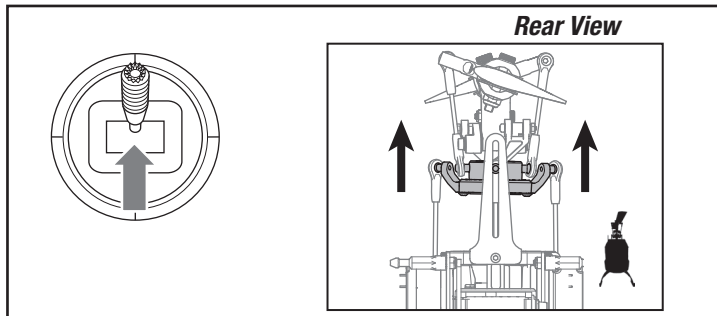

Motor Test

Place the helicopter outdoors on a clean, flat and level surface (concrete or asphalt) free of obstructions. Always stay clear of moving rotor blades.

1. Before you continue, confirm that TH HOLD is ON. The motor will emit 5 ascending tones after the helicopter's ESC has armed properly.

WARNING: The motor will spin when the throttle is increased while TH HOLD is OFF.

WARNING: Stay at least 30 feet (10 meters) away from the helicopter when the motor is running. Do not attempt to fly the helicopter at this time.

2. Ensure the throttle is lowered completely. Confirm the transmitter is still set to normal flight mode. Turn throttle hold OFF to enable throttle control. Slowly increase the throttle until the blades begin to spin. The main blades spin clockwise when viewing the helicopter from the top. The tail rotor blades spin counterclockwise when viewing the helicopter from the right-hand side.

Pre-Flight Checklist

- Check all screws and ensure that they are tight
- Check belt tension and ensure that it is not too tight or too loose
- Check main and tail blades to ensure they are not damaged
- Check all links and make sure they move freely but do not pop off easily
- Check that flight battery and transmitter battery are fully charged
- Check all wires to ensure that they are not cut, pinched, or chafed and are properly secured
- Check all wire connections
- Check gears and make sure no teeth are missing
- Do a complete control test
- Verify the AR636A sensor is correcting in the proper directions
- Check that servos are functioning properly
- Check to make sure flight battery is properly secured
- Check to make sure AR636A is properly secured

Flying the Blade 360 CFX 3S

Consult local laws and ordinances before choosing a location to fly your aircraft.

Select a large, open area away from people and objects. Your first flights should be outdoors in low-wind conditions. Always stay at least 30 feet (10 meters) away from the helicopter when it is flying.

The Blade 360 CFX 3S is intended to be flown outdoors by experienced pilots

Takeoff

Deliberately increase throttle and establish a hover at least 24" (0.6 meter) high, outside of ground effect.

CAUTION: Making large inputs to the roll or pitch controls while the helicopter is on the ground may result in a crash.

Flying

The helicopter lifts off the ground when the rotor head reaches a suitable speed. Establish a low-level hover to verify proper operation of your helicopter.

First flights should be performed in normal mode and low cyclic and rudder dual rates until you are familiar with the flying manner of the Blade 360 CFX 3S.

Gyro Gain Adjustment

- If the tail wags or oscillates, lower the gain on the gyro.

On your transmitter's gyro menu, decrease the gyro gain values a small amount at a time until the helicopter is stable within a particular flight mode.

- If the tail is drifting while hovering, increase the gain on the gyro.

On your transmitter, increase the gyro gain values a small amount at a time until the tail starts to wag/oscillate. Afterwards, reduce the gain until the tail stops wagging/oscillating within a particular flight mode.

Tail Belt Tension

Belt tension that is too tight results in loss of power and causes the belt to wear more quickly. Tension that is too loose can cause belt damage and loss of tail rotor control in flight.

To check for proper belt tension:

1. View the tail rotor drive belt through the opening at the back of the main frame.
2. Use a hex wrench or standard screwdriver to compress the belt through the opening.
3. Apply light pressure on the belt, compressing the belt toward the left side of the tail boom.
4. The belt tension is correct if the compressed side of the belt reaches approximately halfway to the opposite side of the belt.
 - a. If the compressed side of the belt reaches farther than halfway to the other side of the belt, the tension is too loose.
 - b. If the compressed side of the belt does not reach halfway to the other side of the belt, the tension is too tight.

To adjust belt tension:

1. Loosen the two horizontal stabilizer screws.
2. Loosen the 2 screws at the back of the main frame.
3. Slide the boom forward or aft to adjust the belt tension.
4. When the belt tension is properly adjusted, tighten the 2 screws at the back of the frame.
5. Tighten the horizontal stabilizer screws.

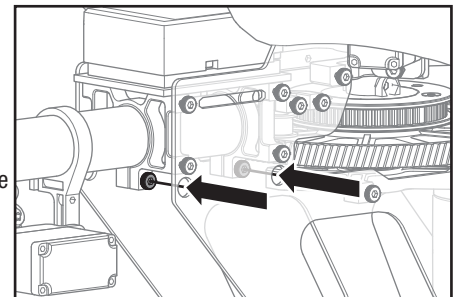

Post-Flight Inspections and Maintenance

Ball Links	Make sure the plastic ball link holds the control ball, but is not tight (binding) on the ball. When a link is too loose on the ball, it can separate from the ball during flight and cause a crash. Replace worn ball links before they fail.
Cleaning	Make sure the battery is not connected before cleaning. Remove dust and debris with a soft brush or a dry lint free cloth.
Bearings	Replace bearings when they become damaged.
Wiring	Make sure wiring does not block moving parts. Replace damaged wiring and loose connectors.
Fasteners	Make sure there are no loose screws, other fasteners or connectors. Do not over tighten metal screws in plastic parts. Tighten screw so parts are mated together, then turn screw only 1/8th of a turn more.
Rotors	Make sure there is no damage to rotor blades and other parts which move at high speed. Damage to these parts includes cracks, burrs, chips or scratches. Replace damaged parts before flying.
Flight Controller	Make sure the AR636A is securely attached to the frame. Replace the double-sided tape when necessary. The helicopter will crash if the AR636A separates from the helicopter frame.

Advanced Settings

The 360 CFX 3S default settings are appropriate for most users. We recommend flying with the default parameters before making any adjustments.

 **WARNING:** To ensure your safety, always disconnect the motor wires from the ESC before performing the following steps. After you have completed the adjustments, reconnect the motor wires to the ESC before attempting to fly the model.

Gain Parameters

1. Cyclic P Gain Adjustment (Default 100%)

Higher gain will result in greater stability. Setting the gain too high may result in random twitches if your model has an excessive level of vibration. High frequency oscillations may also occur if the gain is set too high.

Lower gain will result in less stability. Too low of a value may result in a less stable model particularly outdoors in winds.

If you are located at a higher altitude or in a warmer climate, higher gains may be beneficial—the opposite is true for lower altitude or colder climates.

2. Cyclic I Gain Adjustment (Default 100%)

Higher gain will result in the model remaining still, but may cause low frequency oscillations if increased too far.

Lower gain will result in the model drifting slowly.

If you are located at a higher altitude or in a warmer climate, higher gains may be beneficial—the opposite is true for lower altitude or colder climates.

3. Cyclic D Gain Adjustment (Default 100%)

Higher gain will improve the response rate of your inputs. If the gain is raised too much, high frequency oscillations may occur.

Lower gain will slow down the response to inputs.

4. Cyclic Response (Default 100%)

Higher cyclic response will result in a more aggressive cyclic response.

Lower cyclic response will result in a less aggressive cyclic response.

5. Tailrotor P Gain Adjustment (Default 100%)

Higher gain will result in greater stability. Setting the gain too high may result in random twitches if your model has an excessive level of vibration. High frequency oscillations may also occur if the gain is set too high.

Lower gain may result in a decrease in stability. Too low of a value may result in a less stable model particularly outdoors in winds.

If you are located at a higher altitude or in a warmer climate, higher gains may be beneficial—the opposite is true for lower altitude or colder climates.

6. Tailrotor I Gain Adjustment (Default 100%)

Higher gain results in the tail remaining still. If the gain is raised too far, low speed oscillations may occur.

Lower gain will result in the tail drifting in flight over time.

If you are located at a higher altitude or in a warmer climate, higher gains may be beneficial—the opposite is true for lower altitude or colder climates.

7. Tailrotor D Gain Adjustment (Default 100%)

Higher gain will improve the response rate to your inputs. If raised too far, high frequency oscillations may occur.

Lower gain will slow down the response to inputs, but will not have an effect on stability.

Entering Gain Adjustment Mode

DX6G2, DX6e and DX6i Users:

1. Lower the throttle stick to the lowest position.
2. Power ON the transmitter.
3. Install the flight battery on the helicopter frame, securing it with the hook and loop strap.
4. Connect the battery connector to the ESC.
5. Before initialization is complete, move and hold both transmitter sticks to the bottom right corner as shown.
6. When the servos move, you have entered Gain Adjustment Mode.
7. Release the sticks and proceed to Adjusting the Gain Values to make any desired changes.

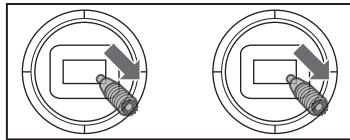

DX7s / DX7 G2 / DX8 / DX8 G2 / DX9 / DX18 / DX20 Users:

1. Lower the throttle stick to the lowest position.
2. Power ON the transmitter.
3. Install the flight battery on the helicopter frame, securing it with the hook and loop strap.
4. Connect the battery connector to the ESC.
5. Place the helicopter on a flat surface and leave it still until the orange receiver LED glows solid, indicating initialization is complete.
6. Move and hold both transmitter sticks to the bottom right corner as shown.
7. Press and hold the bind/panic switch until the swash servos move.
8. Release the sticks and the bind/panic switch. The model is now in Gain Adjustment Mode.
9. Proceed to Adjusting the Gain Values to make any desired changes.

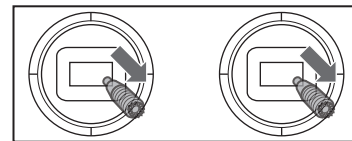

Adjusting the Gain Values

If you are using a Spektrum™ telemetry-enabled transmitter, the gain adjustments can be viewed on the Flight Log screen. Refer to your transmitter instructions to locate this screen. The gain parameter currently selected will flash on the transmitter screen. If you are not using a Spektrum telemetry-enabled transmitter, the parameter and gain values are indicated by the position of the swashplate on the helicopter.

Flight Log Screen

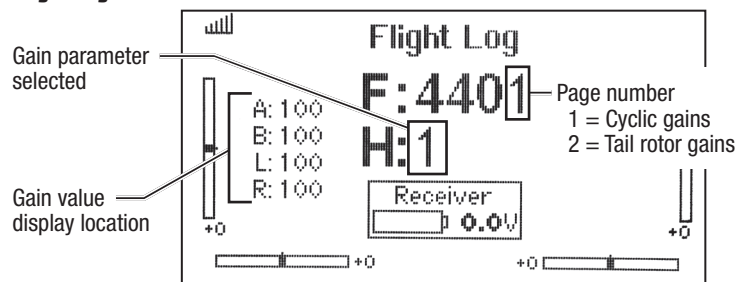

The current gain value for the selected parameter is indicated on the Flight Log screen and by the angle of the swashplate (forward or backward) as shown in the table at the right.

Move the cyclic stick left to right to adjust the gain value. Moving the stick right will increase the gain value. Moving the stick left will decrease the gain value.

It is always best to adjust one gain at a time. Make small adjustments (5% or less) and test fly the model to evaluate the adjustments that were made.

If you would like to reset the current gain value to the default value of 100%, move and hold the rudder stick full right for 1 second. The swash will level on the pitch axis, indicating a 100% gain setting.

Saving the Gain Adjustments

DX6, DX6e and DX6i Users:

1. Lower the throttle stick to the lowest position and release the sticks.
2. Move the tail rotor stick to the left and hold until the servos move.
3. Release the tail rotor stick to save the gain adjustments.
4. Reconnect the main drive motor to the ESC. Your model is now ready for flight.

DX7s / DX7 G2 / DX8 / DX8 G2 / DX9 / DX18 / DX20 Users:

1. Lower the throttle stick to the lowest position and release the sticks.
2. Press and hold switch I until the swash servos move.
3. Release switch I to save the gain adjustments.
4. Reconnect the main drive motor to the ESC. Your model is now ready for flight.

Swash Position	Gain Value
Full backward	0%
50% backward	50%
Level forward and backward	100%
50% forward	150%
Full forward	200%

Once you have entered Gain Adjustment Mode, you can move the cyclic stick forward and back to select the gain parameter you would like to adjust. Moving the stick aft will select the next parameter. Moving the stick will select the previous parameter.

The selected gain parameter is indicated on the Flight Log screen and by the lean of the swashplate on the roll axis.

Parameter #	Display location	Swash Position	Page #
1	A	100% to the Left	1
2	B	50% to the Left	1
3	L	25% to the Left	1
4	R	Swashplate Level	1
5	A	25% to the Right	2
6	B	50% to the Right	2
7	L	100% to the Right	2

Servo Adjustment

The Blade 360 CFX 3S is setup at the factory and test flown. The servo adjustment steps are usually only necessary in special circumstances, such as after a crash or if a servo or linkage is replaced.

WARNING: To ensure your safety, always disconnect the motor wires from the ESC before performing the following steps. After you have completed the adjustments, reconnect the motor wires to the ESC before attempting to fly the model.

Entering Servo Adjustment Mode

DX6G2, DX6e and DX6i Users:

1. Lower the throttle stick to the lowest position.
2. Power ON the transmitter.
3. Install the flight battery on the helicopter frame, securing it with the hook and loop strap.
4. Connect the battery connector to the ESC.
5. Before initialization is complete, hold the left stick to the bottom left corner and the right stick to the bottom right corner as shown.
6. When the swashplate servos move, you have entered Servo Adjustment Mode.
7. Release the sticks and proceed to Adjusting the Servo Neutral Position to make any desired changes.

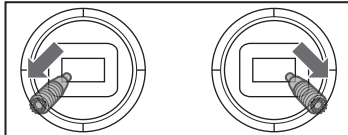

DX7s / DX7 G2 / DX8 / DX8 G2 / DX9 / DX18 / DX20 Users:

1. Lower the throttle stick to the lowest position.
2. Power ON the transmitter.
3. Install the flight battery on the helicopter frame, securing it with the hook and loop strap.
4. Connect the battery connector to the ESC.
5. Place the helicopter on a flat surface and leave it still until the orange receiver LED glows solid, indicating initialization is complete.
6. Hold the left stick to the bottom left corner and the right stick to the bottom right corner as shown.
7. Hold the bind/panic switch until the swash servos move.
8. Release the sticks and the bind/panic switch. The model is now in Servo Adjustment Mode.
9. Proceed to Adjusting the Servo Neutral Position to make any desired changes.

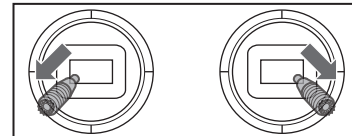

Adjusting the Servo Neutral Position

With the model in Servo Adjustment Mode, the control stick and gyro inputs are disabled and the servos are held in the neutral position. Check the position of the servo arms to see if they are perpendicular to the servos.

- If the arms are perpendicular to the servos, no adjustment is necessary. Exit Servo Adjustment Mode.
- If one or more servo arm is not perpendicular to the servos, continue the servo adjustment process.

While watching the swashplate servos, apply forward cyclic and release. One of the servos will jump, indicating which servo is selected. Press forward cyclic and release until the servo that needs to be adjusted is selected.

Once the servo you wish to adjust is selected, move the cyclic stick left to right to adjust the servo neutral position in the desired direction.

If you would like to reset the current servo to the default neutral position, hold the rudder stick full right for 1 second.

The range of adjustment is limited. If you are unable to adjust the servo arm to be perpendicular to the servo, you must reset the servo to the default neutral position, remove the servo arm and place it back onto the servo as close to perpendicular as possible. You may then adjust the servo neutral position using the left/right cyclic stick.

Swashplate Leveling

Before saving your adjustments and exiting servo adjustment mode, verify the swashplate is level and both main rotor blades are at 0 degrees.

If they are not, make linkage adjustments as necessary.

Saving the Servo Adjustments

DX6, DX6e, and DX6i Users:

1. Lower the throttle stick to the lowest position and release the sticks.
2. Move the tail rotor stick to the left and hold until the servos move.
3. Release the tail rotor stick to save the servo adjustments.
4. Reconnect the main drive motor to the ESC. Your model is now ready for flight.

DX7s / DX7 G2 / DX8 / DX8 G2 / DX9 / DX18 / DX20 Users:

1. Lower the throttle stick to the lowest position and release the sticks.
2. Press and hold switch I until the swash servos move.
3. Release switch I to save the servo adjustments.
4. Reconnect the main drive motor to the ESC. Your model is now ready for flight.

All of the settings are stored internally, so your adjustments will be maintained each time you initialize the model.

Troubleshooting Guide

Problem	Possible Cause	Solution
Helicopter will not bind to the transmitter (during binding)	Low flight battery or transmitter battery voltage	Fully charge or replace the flight battery and/or transmitter batteries
	AR636A is not in bind mode	Make sure the bind plug is connected to the AR636A BND/DAT port
	Transmitter is not in bind mode	Power on the transmitter while holding the Trainer/Bind switch. Hold the Trainer/Bind switch until binding is complete
	Transmitter too close to the helicopter during binding process	Power off the transmitter. Move the transmitter further away from the helicopter. Disconnect and reconnect the flight battery to the helicopter and follow binding instructions
Helicopter will not link to the transmitter (after binding)	Helicopter is bound to a different model memory (ModelMatch™ radios only)	Disconnect the flight battery. Select the correct model memory on the transmitter Reconnect the flight battery
	Flight battery/Transmitter battery charge is too low	Replace or recharge batteries
AR636A will not initialize	The helicopter was moved during initialization	Lay the helicopter on its side during initialization if windy
	The transmitter is powered off	Power on the transmitter
	Controls are not centered	Center elevator, aileron and rudder controls. Make sure the throttle is at idle
Helicopter will not respond to the throttle but responds to other controls	Throttle not at idle and/or throttle trim is too high	Lower the throttle stick and lower the throttle trim
	The transmitter is not in normal mode or throttle hold is on	Make sure the transmitter is in normal mode and throttle hold is off
	The motor is not connected to the ESC or the motor wires are damaged	Connect the motor wires to the ESC and check motor wires for damage
	Flight battery charge is too low	Replace or recharge flight battery
	Throttle channel is reversed	Reverse the throttle channel on the transmitter
Helicopter power is lacking	Flight battery has low voltage	Fully charge the flight battery
	Flight battery is old or damaged	Replace the flight battery
	Flight battery cells are unbalanced	Fully charge the flight battery, allowing the charger time to balance the cells
	Excessive current is being drawn through the BEC	Check all servos and the helicopter motor for damage
	Tail drive belt tension is not correct	See "Checking Tail Drive Belt Tension" in this manual
Helicopter will not lift off	Main rotor head is not spinning in the correct direction	Make sure the main rotor head is spinning clockwise. Refer to the motor control test
	Transmitter settings are not correct	Check throttle and pitch curve settings and pitch control direction
	Flight battery has low voltage	Fully charge the flight battery
	Main rotor blades are installed backwards	Install the main rotor blades with the thicker side as the leading edge
The helicopter tail spins out of control	Rudder control and/or sensor direction reversed	Make sure the rudder control and the rudder sensor are operating in the correct direction
	Tail servo is damaged	Check the rudder servo for damage and replace if necessary
	Inadequate control arm throw	Check the rudder control arm for adequate travel and adjust if necessary
	Tail belt is too loose	Make sure the tail drive belt tension is adjusted correctly
The helicopter wobbles in flight	Cyclic gain is too high	Please review the Advanced Settings - Gain Adjustments section
	Head speed is too low	Increase the helicopter's head speed via your transmitter settings and/or using a freshly charged flight pack
	Dampers are worn	Replace the main rotor head dampers

Limited Warranty

What this Warranty Covers

Horizon Hobby, LLC, (Horizon) warrants to the original purchaser that the product purchased (the "Product") will be free from defects in materials and workmanship at the date of purchase.

What is Not Covered

This warranty is not transferable and does not cover (i) cosmetic damage, (ii) damage due to acts of God, accident, misuse, abuse, negligence, commercial use, or due to improper use, installation, operation or maintenance, (iii) modification of or to any part of the Product, (iv) attempted service by anyone other than a Horizon Hobby authorized service center, (v) Product not purchased from an authorized Horizon dealer, (vi) Product not compliant with applicable technical regulations, or (vii) use that violates any applicable laws, rules, or regulations.

OTHER THAN THE EXPRESS WARRANTY ABOVE, HORIZON MAKES NO OTHER WARRANTY OR REPRESENTATION, AND HEREBY DISCLAIMS ANY AND ALL IMPLIED WARRANTIES, INCLUDING, WITHOUT LIMITATION, THE IMPLIED WARRANTIES OF NON-INFRINGEMENT, MERCHANTABILITY AND FITNESS FOR A PARTICULAR PURPOSE. THE PURCHASER ACKNOWLEDGES THAT THEY ALONE HAVE DETERMINED THAT THE PRODUCT WILL SUITABLY MEET THE REQUIREMENTS OF THE PURCHASER'S INTENDED USE.

Purchaser's Remedy

Horizon's sole obligation and purchaser's sole and exclusive remedy shall be that Horizon will, at its option, either (i) service, or (ii) replace, any Product determined by Horizon to be defective. Horizon reserves the right to inspect any and all Product(s) involved in a warranty claim. Service or replacement decisions are at the sole discretion of Horizon. Proof of purchase is required for all warranty claims. SERVICE OR REPLACEMENT AS PROVIDED UNDER THIS WARRANTY IS THE PURCHASER'S SOLE AND EXCLUSIVE REMEDY.

Limitation of Liability

HORIZON SHALL NOT BE LIABLE FOR SPECIAL, INDIRECT, INCIDENTAL OR CONSEQUENTIAL DAMAGES, LOSS OF PROFITS OR PRODUCTION OR COMMERCIAL LOSS IN ANY WAY, REGARDLESS OF WHETHER SUCH CLAIM IS BASED IN CONTRACT, WARRANTY, TORT, NEGLIGENCE, STRICT LIABILITY OR ANY OTHER THEORY OF LIABILITY, EVEN IF HORIZON HAS BEEN ADVISED OF THE POSSIBILITY OF SUCH DAMAGES. Further, in no event shall the liability of Horizon exceed the individual price of the Product on which liability is asserted. As Horizon has no control over use, setup, final assembly, modification or misuse, no liability shall be assumed nor accepted for any resulting damage or injury. By the act of use, setup or assembly, the user accepts all resulting liability. If you as the purchaser or user are not prepared to accept the liability associated with the use of the Product, purchaser is advised to return the Product immediately in new and unused condition to the place of purchase.

Law

These terms are governed by Illinois law (without regard to conflict of law principals). This warranty gives you specific legal rights, and you may also have other rights which vary from state to state. Horizon reserves the right to change or modify this warranty at any time without notice.

WARRANTY SERVICES

Questions, Assistance, and Services

Your local hobby store and/or place of purchase cannot provide warranty support or service. Once assembly, setup or use of the Product has been started, you must contact your local distributor or Horizon directly. This will enable Horizon to better answer your questions and service you in the event that you may need any assistance. For questions or assistance, please visit our website at www.horizonhobby.com, submit a Product Support Inquiry, or call the toll free telephone number referenced in the Warranty and Service Contact Information section to speak with a Product Support representative.

Inspection or Services

If this Product needs to be inspected or serviced and is compliant in the country you live and use the Product in, please use the Horizon Online Service Request submission process found on our website or call Horizon to obtain a Return Merchandise Authorization (RMA) number. Pack the Product securely using a shipping carton. Please note that original boxes may be included, but are not designed to withstand the rigors of shipping without additional protection. Ship via a carrier that provides tracking and insurance for lost or damaged parcels, as Horizon is not responsible for merchandise until it arrives and is accepted at our facility. An Online Service Request is available at http://www.horizonhobby.com/content/service-center_render-service-center. If you do not have internet access, please contact Horizon Product Support to obtain a RMA number along with instructions for submitting your product for service. When calling Horizon, you will be asked to provide your complete name, street address, email address and phone number where you can be reached during business hours. When sending product into Horizon, please include your RMA number, a list of the included items, and a brief summary of the problem. A copy of your original sales receipt must be included for warranty consideration. Be sure your name, address, and RMA number are clearly written on the outside of the shipping carton.

NOTICE: Do not ship LiPo batteries to Horizon. If you have any issue with a LiPo battery, please contact the appropriate Horizon Product Support office.

Warranty Requirements

For Warranty consideration, you must include your original sales receipt verifying the proof-of-purchase date. Provided warranty conditions have been met, your Product will be serviced or replaced free of charge. Service or replacement decisions are at the sole discretion of Horizon.

Non-Warranty Service

Should your service not be covered by warranty, service will be completed and payment will be required without notification or estimate of the expense unless the expense exceeds 50% of the retail purchase cost. By submitting the item for service you are agreeing to payment of the service without notification. Service estimates are available upon request. You must include this request with your item submitted for service. Non-warranty service estimates will be billed a minimum of ½ hour of labor. In addition you will be billed for return freight. Horizon accepts money orders and cashier's checks, as well as Visa, MasterCard, American Express, and Discover cards. By submitting any item to Horizon for service, you are agreeing to Horizon's Terms and Conditions found on our website http://www.horizonhobby.com/content/service-center_render-service-center.

ATTENTION: Horizon service is limited to Product compliant in the country of use and ownership. If received, a non-compliant Product will not be serviced. Further, the sender will be responsible for arranging return shipment of the un-serviced Product, through a carrier of the sender's choice and at the sender's expense. Horizon will hold non-compliant Product for a period of 60 days from notification, after which it will be discarded. 10/15

Warranty and Service Contact Information

Country of Purchase	Horizon Hobby	Contact Information	Address
United States of America	Horizon Service Center (Repairs and Repair Requests)	servicecenter.horizonhobby.com/RequestForm/	4105 Fieldstone Rd Champaign, Illinois, 61822 USA
	Horizon Product Support (Product Technical Assistance)	productsupport@horizonhobby.com 877-504-0233	
	Sales	websales@horizonhobby.com 800-338-4639	
European Union	Horizon Technischer Service Sales: Horizon Hobby GmbH	service@horizonhobby.eu +49 (0) 4121 2655 100	Hanskampring 9 D 22885 Barsbüttel, Germany

FCC Information

FCC ID: BRWDASRX15

This equipment has been tested and found to comply with the limits for Part 15 of the FCC rules. These limits are designed to provide reasonable protection against harmful interference in a residential installation. This equipment generates uses and can radiate radio frequency energy and, if not installed and used in accordance with the instructions, may cause harmful interference to radio communications.

However, there is no guarantee that interference will not occur in a particular installation. If this equipment does cause harmful interference to radio or television reception, which can be determined by turning the equipment off and on, the user is encouraged to try to correct the interference by one or more of the following measures:

- Reorient or relocate the receiving antenna.
- Increase the separation between the equipment and receiver.
- Connect the equipment to an outlet on a circuit different from that to which the receiver is connected.

This device complies with part 15 of the FCC rules. Operation is subject to the following two conditions: (1) This device may not cause harmful interference, and (2) this device must accept any interference received, including interference that may cause undesired operation.

NOTICE: Modifications to this product will void the user's authority to operate this equipment.

IC Information

IC: 6157A-AMRX15

This device complies with Industry Canada licence-exempt RSS standard(s). Operation is subject to the following two conditions: (1) this device may not cause interference, and (2) this device must accept any interference received, including interference that may cause undesired operation of the device."

Compliance Information for the European Union

EU Compliance Statement:

Horizon Hobby, LLC hereby declares that this product is in compliance with the essential requirements and other relevant provisions of the RED and EMC directives. A copy of the EU Declaration of Conformity is available online at: <http://www.horizonhobby.com/content/support-render-compliance>.

Instructions for disposal of WEEE by users in the European Union

 This product must not be disposed of with other waste. Instead, it is the user's responsibility to dispose of their waste equipment by handing it over to a designated collections point for the recycling of waste electrical and electronic equipment. The separate collection and recycling of your waste equipment at the time of disposal will help to conserve natural resources and make sure that it is recycled in a manner that protects human health and the environment. For more information about where you can drop off your waste equipment for recycling, please contact your local city office, your household waste disposal service or where you purchased the product.



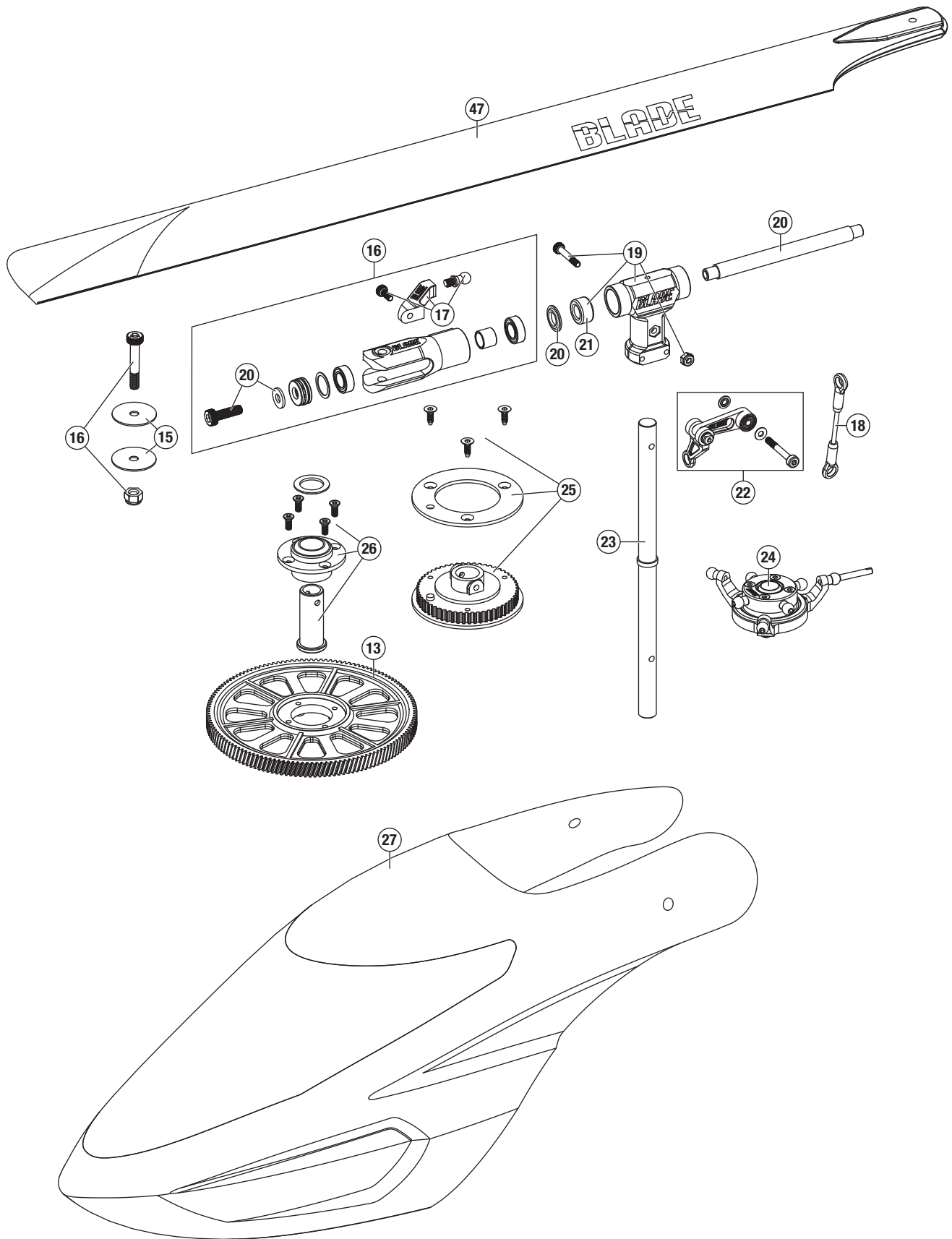

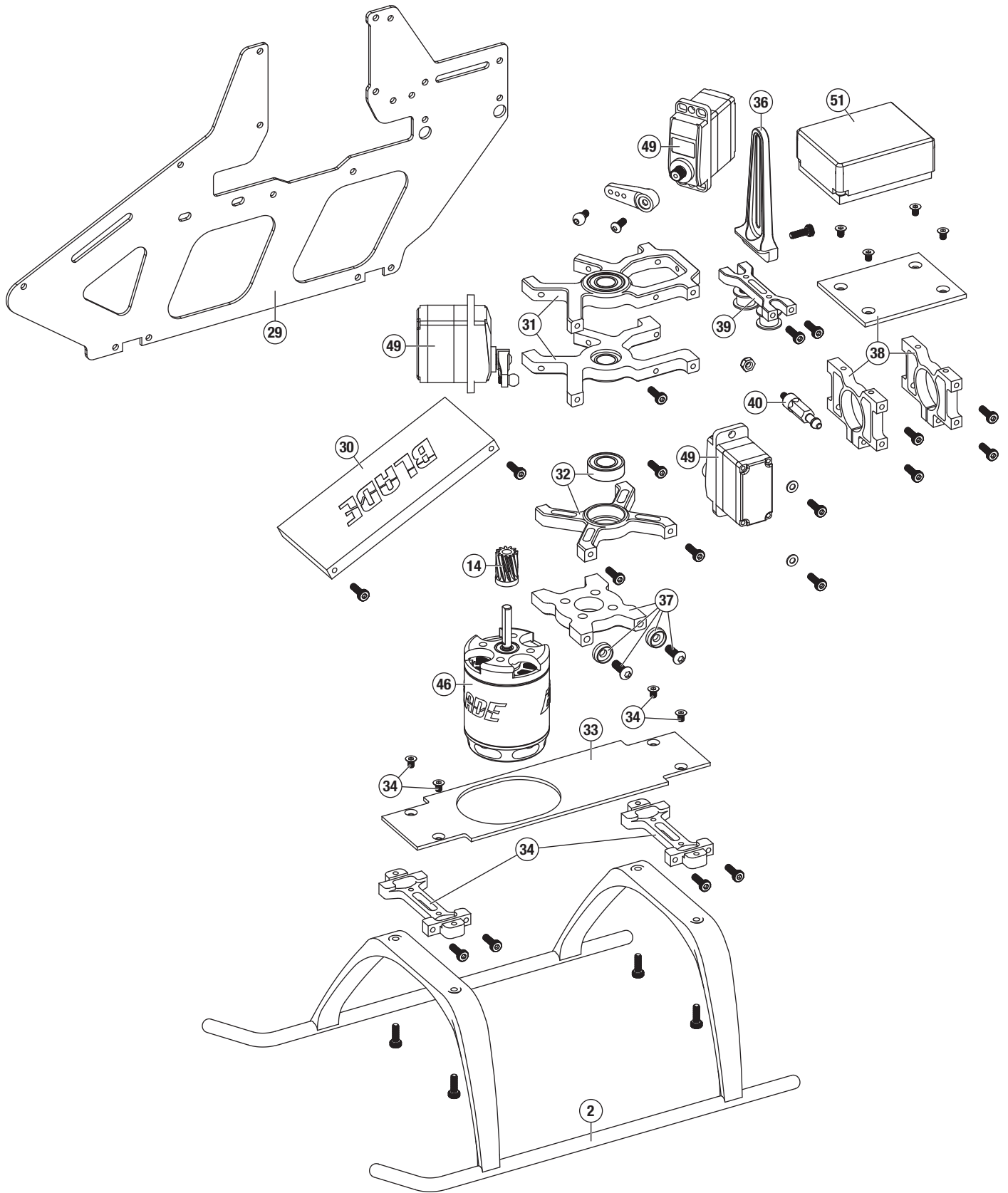

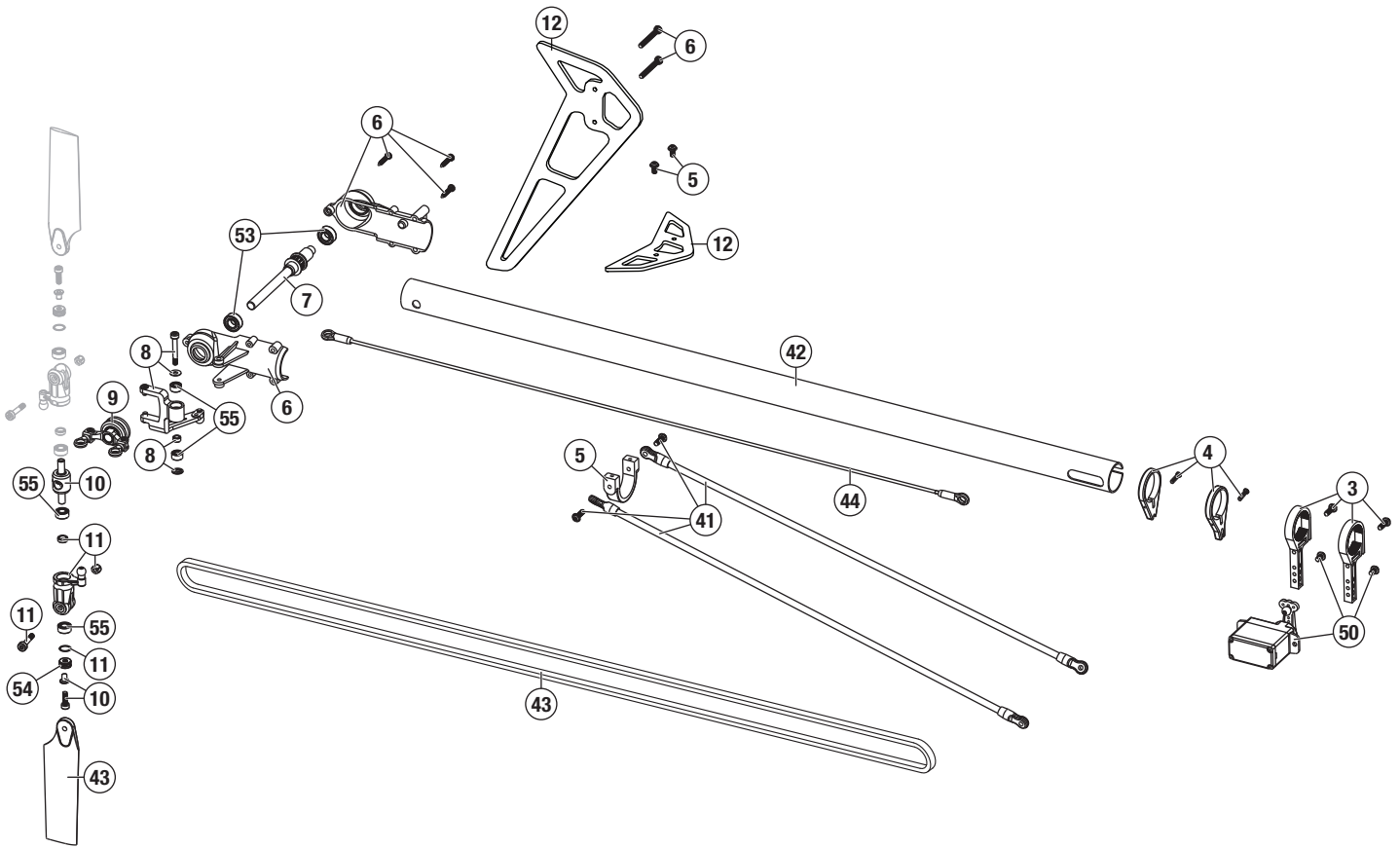

Parts List / Ersatzteile / Pièces de Rechange / Pezzi di Ricambio

#	Part #	English	Deutsch	Français	Italiano
1	BLH1636	Control/Linkage Ball, Short (10): 360 CFX	Blade Kugelköpfe kurz (10): 360 CFX	Tringleries courtes/rotules (10) : 360 CFX	Sfere per i rinvi, corte (10): 360 CFX
2	BLH1645	Landing Gear Set: 360 CFX	Blade Landegestell: 360CFX	Train d'atterrissage: 360 CFX	Set carrello di atterraggio: 360 CFX
3	BLH1654	Tail Servo Boom Mount (2): 360 CFX	Blade Heckrohr (2): 360CFX	Support de servo d'anticouple: 360 CFX	Supporto servo per tubo coda (2): 360 CFX
4	BLH1660	Tail Pushrod Support/Guide Set: 360 CFX	Blade Halter Heckrotoranlenkstange: 360CFX	Guide de tringlerie d'anticouple	Set supporto/guida per comando coda: 360 CFX
5	BLH1662A	Aluminum Horizontal Stab Fin Mount: 360 CFX	Blade Aluminium Leitwerksbefestigung/ Heckfinne: 360 CFX	Support de stabilisateur en aluminium: 360 CFX	Supporto in alluminio per piano di coda orizzontale: 360 CFX
6	BLH1663	Tail Case Set: 360 CFX	Blade Heckrotor Gehäuse: 360 CFX	Boîtier d'anticouple: 360 CFX	Set scatola coda: 360 CFX
7	BLH1665	Tail Rotor Shaft and Drive Pulley (2): 360 CFX	Blade Heckrotorschacht (2): 360 CFX	Axe d'anticouple: 360 CFX	Albero rotore di coda con puleggia (2): 360 CFX
8	BLH1667	Tail Rotor Pitch Lever Set: 360 CFX	Blade Heckrotor Anlenkungset: 360 CFX	Levier d'anticouple: 360 CFX	Set leva passo per rotore di coda: 360 CFX
9	BLH1668	Tail Rotor Pitch Control Slider Set: 360 CFX	Heckrotorschiebebehülse Set : 360 CFX	Coulisseau d'anticouple: 360 CFX	Set cursore controllo passo rotore di coda: 360 CFX
10	BLH1669	Tail Rotor Hub Set: 360 CFX	Heckrotor Zentralstück Set : 360 CFX	Moyeu d'anticouple: 360 CFX	Set mozzo rotore di coda: 360 CFX
11	BLH1670	Tail Rotor Blade Grip/Holder Set: 360 CFX	Blatthalter Heckrotor: 360 CFX	Pieds de pales d'anticouple: 360 CFX	Set portapala rotore di coda: 360 CFX
12	BLH5049	Green Carbon Fiber Fins: 360 CFX	Carbon Leitwerk / Heckfinne : 360 CFX	Dérive et stabilisateur en carbone: 360 CFX	Set piani di coda, fibra di carbonio: 360 CFX
13	BLH1901	Helical Main Gear: 360 CFX	Hauptzahnrad schrägverz.: 360 CFX	Couronne principales hélicoïdale: 360 CFX	Ingranaggio principale elicoidale: 360 CFX
14	BLH1902	Helical Pinion, 10T: 360 CFX	Ritzel 10 Z schrägverz.: 360 CFX	Pignon 10T hélicoïdal	Pignone elicoidale, 10T: 360 CFX
15	BLH4304	Main Blade Shims (4): 360 CFX	Unterlegscheiben Rotorblatthalter (4): 360 CFX	Rondelles de pales principales (4): 360 CFX	Spessori per pala principale (4): 360 CFX
16	BLH4701	Fbl Main Rotor Grip Set: 360 CFX	Rotorblatthalterset: 360 CFX	Pieds de pales principales FBL: 360 CFX	Set portapala Fbl rotore principale: 360 CFX
17	BLH4702	Fbl Main Grip Arms: 360 CFX	Rotorblatthalter: 360 CFX	Leviers de pieds de pales principales: 360 CFX	Bracci portapala principale Fbl: 360 CFX
18	BLH4703	Fbl Linkage Set: 360 CFX	Flybarlessanlenkungen: 360 CFX	Tringleries FBL: 360 CFX	Set rinvi Fbl: 360 CFX

#	Part #	English	Deutsch	Français	Italiano
19	BLH4704	Fbl Aluminum Head Block: 360 CFX	Rotorkopfblock Alu: 360 CFX	Moyeu de tête en aluminium: 360 CFX	Blocco testa Fbl in alluminio: 360 CFX
20	BLH4705	Spindle Set (2): 360 CFX	Spindelset (2): 360 CFX	Axe de pieds de pales: 360 CFX	Set alberino (2): 360 CFX
21	BLH4706	Dampers (4): 360 CFX	Dämpfer (4): 360 CFX	Amortisseurs (4): 360 CFX	Smorzatori (4): 360 CFX
22	BLH4707	Fbl Follower Arms: 360 CFX	Taumelscheibenmitnehmer: 360 CFX	Bras FBL: 360 CFX	Fbl Squadretta rinvio: 360 CFX
23	BLH4708	Main Shaft (2): 360 CFX	Hauptrotorwelle (2): 360 CFX	Axe principal: 360 CFX	Albero principale (2): 360 CFX
24	BLH4709	Aluminum Swashplate: 360 CFX	Taumelscheibe Aluminum: 360 CFX	Plateau cyclique en aluminium: 360 CFX	Piatto oscillante in alluminio: 360 CFX
25	BLH4710	Belt Drive Pulley: 360 CFX	Zahnriemenspannrad : 360 CFX	Poulie de transmission d'anticouple: 360 CFX	Puleggia per cinghia: 360 CFX
26	BLH4711	One-Way Bearing Hub w/One way bearing: 360 CFX	Freilauf: 360 CFX	Roue libre avec moyeu: 360 CFX	Mozzo con cuscinetto a ruota libera: 360 CFX
27	BLH5053	Fiberglass Canopy 3s: 360 CFX	Kabinenhaube: 360 CFX	Bulle d'origine en fibre: 360 CFX	Capottina FG di serie: 360 CFX
29	BLH4714	CF Main Frame Set: 360 CFX	Hauptrahmen: 360 CFX	Flancs de châssis en carbone: 360 CFX	Set telaio principale CF: 360 CFX
30	BLH4715	Battery Tray: 360 CFX	Akkuhalter: 360 CFX	Support de batterie: 360 CFX	Supporto batteria: 360 CFX
31	BLH4716	Servo Mounting Blocks: 360 CFX	Servohalter: 360 CFX	Paliers de fixation de servos: 360 CFX	Blocchi supporto servi: 360 CFX
32	BLH4717	Lower Bearing Block: 360 CFX	Lagerblock unten: 360 CFX	Palier inférieur: 360 CFX	Blocco cuscinetto inferiore: 360 CFX
33	BLH4718	Bottom Plate: 360 CFX	Bodenplatte: 360 CFX	Platine inférieure: 360 CFX	Piastra inferiore: 360 CFX
34	BLH4719	Landing Gear Mounts: 360 CFX	Halter Kufengestell: 360 CFX	Supports de train d'atterrissage	Supporti carrello: 360 CFX
35	BLH4720	Linkage Set: 360 CFX	Anlenkungssset: 360 CFX	Tringleries: 360 CFX	Set rinvii di collegamento: 360 CFX
36	BLH4721	Anti-Rotation Bracket: 360 CFX	Taumelscheibenführung: 360 CFX	Guide de plateau cyclique: 360 CFX	Staffa antirotazione: 360 CFX
37	BLH4722	Motor Mount: 360 CFX	Motorhalter: 360 CFX	Support moteur: 360 CFX	Supporto motore: 360 CFX
38	BLH4723	Tail Boom Clamp: 360 CFX	Heckauslegerklampe: 360 CFX	Fixation de poutre de queue: 360 CFX	Supporto tubo coda: 360 CFX
39	BLH4724	Belt Tensioner: 360 CFX	Riemenspanner: 360 CFX	Tendeur de courroie: 360 CFX	Tenditore cinghia: 360 CFX
40	BLH4725	Canopy Posts: 360 CFX	Blade 360 CFX: Kabinenhaubehalter	Supports de bulle: 360 CFX	Appoggi capottina: 360 CFX
41	BLH4726	Boom Support Set: 360 CFX	Blade 360 CFX: Heckauslegerhalter Set	Renforts de poutre: 360 CFX	Set supporto tubo: 360 CFX
42	BLH4727	Boom (2): 360 CFX	Heckrohr: 360 CFX	Poutre (2): 360 CFX	Tubo coda (2): 360 CFX
43	BLH4728	Tail Drive Belt: 360 CFX	Heckrotorriemen: 360 CFX	Courroie d'anticouple	Cinghia trasmissione coda: 360 CFX
44	BLH4729	Tail Pushrod Set (2): 360 CFX	Heckrotorgestänge: 360 CFX	Commande d'anticouple (2) : 360 CFX	Set asta comando coda (2): 360 CFX
45	BLH4730	Tail Rotor Blade Set: 360 CFX	Heckrotorblätter: 360 CFX	Paire de pales d'anticouple	Set pale rotore coda: 360 CFX
46	BLH5051	Brushless Out-Runner Motor, 3400Kv: 360 CFX	Brushless Aussenläufer: 360 CFX	Moteur brushless 1800Kv: 360 CFX	Motore brushless a cassa rotante, 1800Kv: 360 CFX
47	BLH4732	360mm Carbon Fiber Main Rotor Blades	360mm Carbon Hauptrotorblätter: 360 CFX	Pales principales en carbone 360mm: 360 CFX	Pale rotore principale in carbonio da 360mm
49	SPMSH3050	H3050 Sub-Micro Digital Heli Cyclic MG Servo	Spektrum Taumelscheibenservo dig. 9g MG	H3050 Sub-micro-servo digital, pignons métal pour anticouple.	H3050 Servo digitale sub-micro MG per ciclico
50	SPMSH3060	H3060 Sub-Micro Digital Heli Tail MG Servo	Spektrum Heckrotorservo dig. 9g MG	H3060 Sub-micro-servo digital, pignons métal pour cyclique.	H3060 Servo digitale sub-micro MG per coda
51	BLH5054	Spektrum AR636A Replacement receiver: 360 CFX	Spektrum AR636A Austauschempfänger: 360 CFX	Spektrum AR636A Récepteur de recharge : 360 CFX	Spektrum AR636A Ricevente sostitutiva: 360 CFX
52	BLH5052	Brushless ESC 45A	Bürstenloser Geschwindigkeitsregler 45 A	Variateur ESC sans balais 45 A	ESC brushless 45 A
53	BLH1605	4x8x3 bearing Main Grip and Tail shaft (4): B450 3D/X	4 x 8 x 3 Lager Haupthalterung und Heckwelle (4): B450 3D/X	Roulement 4x8x3 de pieds de pales et d'axe anticouple (4) : B450 3D/X	Cuscinetto albero principale e albero di coda 4x8x3 (4): B450 3D/X
54	BLH1612	Tail Grip Thrust Bearings: B450 3D/X	Heckhalterung-Gegenlager: B450 3D/X	Butéés à billes de pied de pale d'anticouple : B450 3D/X	Cuscinetti di spinta stringi pale di coda: B450 3D/X
55	BLH1115	Bearing 3x6x2.5mm (2): B450 3D/X, B400	Lager 3 x 6 x 2,5 mm (2): B450 3D/X, B400	Roulement 3x6x2.5mm (2) : B450 3D/X, B400	Cuscinetto 3x6x2,5 mm (2): B450 3D/X, B400

Optional Parts / Optionale Bauteile / Pièces optionnelles / Pezzi opzionali

Part #	English	Deutsch	Français	Italiano
EFLB30003S30	3000 mAh 3S 11.1V 30C LiPo	3000 mAh 3S 11,1 V 30C LiPo	3000 mAh 3S 11.1V 30C LiPo	3000 mAh 3S 11.1V 30C LiPo
BLH5048	Carbon Fiber Fins	Kohlefaser-Leitwerke	Dérive et stabilisateur en fibre de carbone	Pinne in fibra di carbonio
BLH1903	Helical Pinion 11t	Schrägverzahntes Ritzel 11 t	Pignon hélicoïdal 11 t	Pignone elica 11 denti
BLH1645B	Landing Gear Set Black	Fahrwerksatz, schwarz	Ensemble de train d'atterrissage noir	Set carrello d'atterraggio nero
BLH4712	Optional Blade 360 CFX Canopy	Optionale Rotorblattabdeckung 360 CFX	Verrière optionnelle pour Blade 360 CFX	Capottina opzionale Blade 360 CFX
BLH4713	Optional Blade 360 CFX Canopy	Optionale Rotorblattabdeckung 360 CFX	Verrière optionnelle pour Blade 360 CFX	Capottina opzionale Blade 360 CFX
BLH4752	3-Blade Conversion Set	Umbausatz mit 3 Rotorblättern	Ensemble de conversion tripale	Set conversione tripala
EFLH1000	Micro/Mini Heli Pitch Gauge	Mikro/Mini-Anzeige für Fluglagenwinkel des Hubschraubers	Incidencemètre pour mini/micro hélicoptère	Misuratore di passo elicottero micro/mini

©2018 Horizon Hobby, LLC.

Blade, DSM, DSM2, DSMX, AS3X, ModelMatch, Spektrum AirWare, EC3, BNF, and the BNF logo are trademarks or registered trademarks of Horizon Hobby, LLC.

The Spektrum trademark is used with permission of Bachmann Industries, Inc. Futaba is a registered trademark of Futaba Denshi Kogyo Kabushiki Kaisha Corporation of Japan. All other trademarks, service marks and logos are property of their respective owners.

Patents pending.

Created 01/18

55137.1

BLH5050