

HORIZON[®]
H O B B Y

Eflite[®]
ADVANCING ELECTRIC FLIGHT

Ultimate²

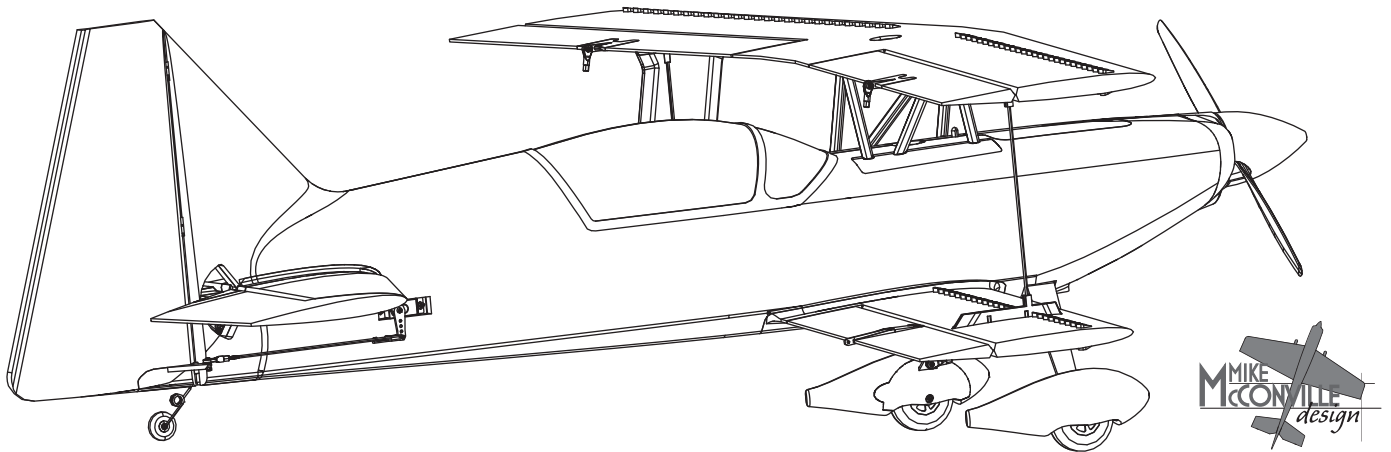

Instruction Manual
Bedienungsanleitung
Manuel d'utilisation
Manuale di Istruzioni

SAFE[®] 

Bind-N-Fly[®]
BASIC

NOTICE

All instructions, warranties and other collateral documents are subject to change at the sole discretion of Horizon Hobby, LLC. For up-to-date product literature, visit www.horizonhobby.com and click on the support tab for this product.

Meaning of Special Language:

The following terms are used throughout the product literature to indicate various levels of potential harm when operating this product:

NOTICE: Procedures, which if not properly followed, create a possibility of physical property damage AND little or no possibility of injury.

CAUTION: Procedures, which if not properly followed, create the probability of physical property damage AND a possibility of serious injury.

WARNING: Procedures, which if not properly followed, create the probability of property damage, collateral damage, and serious injury OR create a high probability of superficial injury.



WARNING: Read the ENTIRE instruction manual to become familiar with the features of the product before operating. Failure to operate the product correctly can result in damage to the product, personal property and cause serious injury.

This is a sophisticated hobby product. It must be operated with caution and common sense and requires some basic mechanical ability. Failure to operate this Product in a safe and responsible manner could result in injury or damage to the product or other property. This product is not intended for use by children without direct adult supervision. Do not use with incompatible components or alter this product in any way outside of the instructions provided by Horizon Hobby, LLC. This manual contains instructions for safety, operation and maintenance. It is essential to read and follow all the instructions and warnings in the manual, prior to assembly, setup or use, in order to operate correctly and avoid damage or serious injury.

14+

AGE RECOMMENDATION:
Not for children under 14 years. This is not a toy.



WARNING AGAINST COUNTERFEIT PRODUCTS: If you ever need to replace your Spektrum receiver found in a Horizon Hobby product, always purchase from Horizon Hobby, LLC or a Horizon Hobby authorized dealer to ensure authentic high-quality Spektrum product. Horizon Hobby, LLC disclaims all support and warranty with regards, but not limited to, compatibility and performance of counterfeit products or products claiming compatibility with DSM or Spektrum.

Safety Precautions and Warnings

As the user of this product, you are solely responsible for operating in a manner that does not endanger yourself and others or result in damage to the product or the property of others.

- Always keep a safe distance in all directions around your model to avoid collisions or injury. This model is controlled by a radio signal subject to interference from many sources outside your control. Interference can cause momentary loss of control.
- Always operate your model in open spaces away from full-size vehicles, traffic and people.
- Always carefully follow the directions and warnings for this and any optional support equipment (chargers, rechargeable battery packs, etc.).
- Always keep all chemicals, small parts and anything electrical out of the reach of children.
- Always avoid water exposure to all equipment not specifically designed and

- protected for this purpose. Moisture causes damage to electronics.
- Never place any portion of the model in your mouth as it could cause serious injury or even death.
- Never operate your model with low transmitter batteries.
- Always keep aircraft in sight and under control.
- Always use fully charged batteries.
- Always keep transmitter powered on while aircraft is powered.
- Always remove batteries before disassembly.
- Always keep moving parts clean.
- Always keep parts dry.
- Always let parts cool after use before touching.
- Always remove batteries after use.
- Always ensure failsafe is properly set before flying.
- Never operate aircraft with damaged wiring.
- Never touch moving parts.

Charging Warnings

CAUTION: All instructions and warnings must be followed exactly. Mishandling of Li-Po batteries can result in a fire, personal injury, and/or property damage.

- **Never leave charging batteries unattended.**
- **Never charge batteries overnight.**
- By handling, charging or using the included Li-Po battery, you assume all risks associated with lithium batteries.
- If at any time the battery begins to balloon or swell, discontinue use immediately. If charging or discharging, discontinue and disconnect. Continuing to use, charge or discharge a battery that is ballooning or swelling can result in fire.
- Always store the battery at room temperature in a dry area for best results.
- Always transport or temporarily store the battery in a temperature range of 40–120° F (5–49° C). Do not store battery or aircraft in a car or direct sunlight. If stored in a hot car, the battery can be damaged or even catch fire.
- Always charge batteries away from flammable materials.
- Always inspect the battery before charging and never charge dead or damaged batteries.
- Always disconnect the battery after charging, and let the charger cool between charges.
- Always constantly monitor the temperature of the battery pack while charging.
- **ONLY USE A CHARGER SPECIFICALLY DESIGNED TO CHARGE LI-PO BATTERIES.** Failure to charge the battery with a compatible charger may cause fire resulting in personal injury and/or property damage.
- Never discharge Li-Po cells to below 3V under load.
- Never cover warning labels with hook and loop strips.
- Never charge batteries outside recommended levels.
- Never attempt to dismantle or alter the charger.
- Never allow minors under the age of 14 to charge battery packs.
- Never charge batteries in extremely hot or cold places (recommended between 40–120° F or 5–49° C) or place in direct sunlight.

To register your product online, visit www.e-fliterc.com

Box Contents

Quick Start Information	
Transmitter Setup	Transmitter setup is required. Refer to the transmitter setup section in this manual.
Center of Gravity (CG)	89mm back from leading edge at the center of the top wing.
Flight Timer Setting	5 minutes

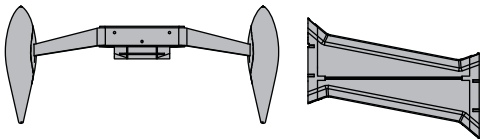
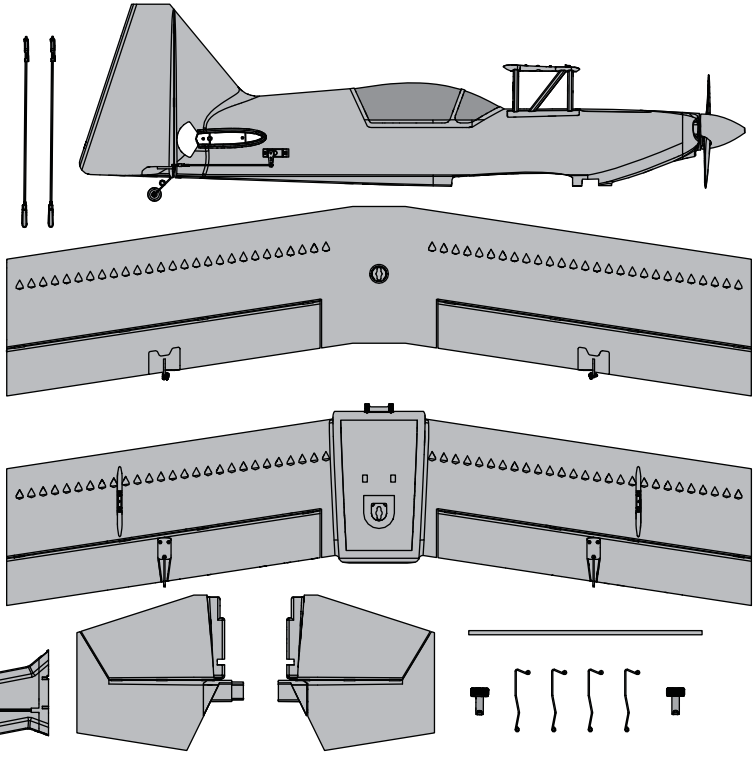

Specifications







	10BL Brushless outrunner 1300Kv	Included
	40-Amp Brushless ESC	Installed
	(4) 13 g Digital Servo (EFLA1040U)	Installed
	Spektrum™ AR636, 6-Channel Sport Receiver	Installed
	Battery: 2200mAh 11.1V 3S 30C Li-Po (EFLB22003S30)	Required to Complete
	Battery Charger: 3-cell Li-Po battery balancing charger	Required to Complete
	Recommended Transmitter: Full-Range 6 channel 2.4GHz with Spektrum DSM2®/DSMX® technology (DX4e and above).	Required to Complete

Table of Contents

Preflight.....	4
SAFE Technology Flight Modes.....	4
Transmitter Setup for this SAFE® Technology Aircraft	5
Model Assembly	6
Control Surface Centering	9
Control Horn and Servo Arm Settings	9
Transmitter and Receiver Binding.....	10
Battery Installation and ESC Arming.....	11
Center of Gravity (CG)	12
Control Direction Test	12
AS3X Control Direction Test	13
In Flight Trimming	13
Flying Tips and Repairs.....	14
Post Flight Checklist	14
Motor Service	15
Troubleshooting Guide AS3X	15
Troubleshooting Guide	16
AMA National Model Aircraft Safety Code.....	17
Limited Warranty	18
Contact Information	19
FCC Information.....	19
IC Information.....	19
Compliance Information for the European Union.....	19
Replacement Parts.....	71
Optional Parts	71

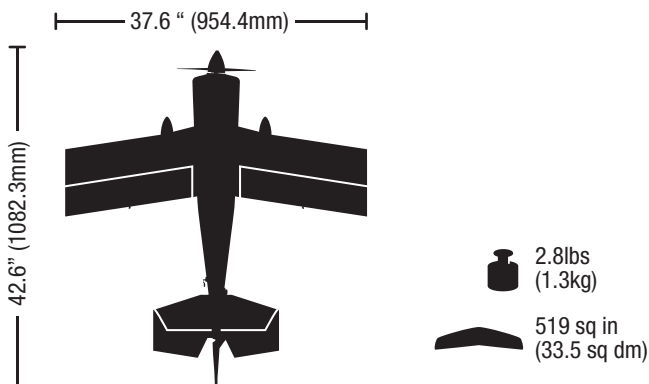

Preflight

1	Remove and inspect contents.
2	Read this instruction manual thoroughly.
3	Charge flight battery.
4	Setup Transmitter using transmitter setup chart.
5	Fully assemble airplane.
6	Install the flight battery in the aircraft (once it has been fully charged).
7	Check the Center of Gravity (CG).
8	Bind aircraft to your transmitter.

9	Make sure linkages move freely.
10	Perform the Control Direction Test with the transmitter.
11	Perform the AS3X Control Direction Test with the aircraft.
12	Adjust flight controls and transmitter.
13	Perform a radio system Range Test.
14	Find a safe open area to fly.
15	Plan flight for flying field conditions.

SAFE Technology Flight Modes

This aircraft has **3 selectable flight modes** and a Panic Recovery feature. It is extremely important to follow the **Transmitter Setup** section of this manual before binding your transmitter to this aircraft.

3D Mode (High Gain):

This mode uses high rates and high gains to deliver extreme maneuverability with maximum stability at low airspeeds. Use this mode for slow flying and 3D maneuvers such as Hovers and Harriers. Flying at high speed in this mode could cause oscillation.

3D Mode (Low Gain):

This mode uses high rates and lower gains to deliver extreme maneuverability with gains set low enough to fly at full power without oscillation.



Precision Mode (Low Rate/Low Gain):

This mode uses low rates and low gains to deliver precise response at high airspeeds. Use this mode to trim the aircraft and fly fast precision maneuvers.



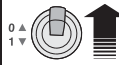

Adjusting the Programming of the AR636

The included AR636 receiver has been programmed for operation specifically for this aircraft. However, you can adjust the programming at anytime by downloading the Spektrum AS3X App, then purchase the Spektrum™ Audio-interface AS3X® receiver programming cable (SPMA3081) or with the Spektrum™ AS3X Programming cable USB interface (SPMA3065).

2 Position Gear/Ch 5 Switch Transmitters

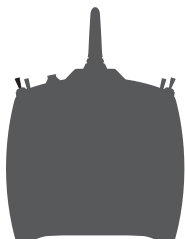
DX6i and DX5e, DX4e (older versions)	3D Mode (High Gain)	
		Position 0 is 3D Mode (High Gain)
	Precision Mode	
		Position 1 is Precision Mode
IMPORTANT: DX6i CH 5 has to be reversed.		

3 Position Gear/Ch 5 Switch Transmitters

DX4e, DX5e, DX6, DX7S, DX7, DX8, DX9, DX18, DX10t	3D Mode (High Gain)	
		Position 0 is 3D Mode (High Gain)
	3D Mode (Low Gain)	
		Position 1 is 3D Mode (Low Gain)
Precision Mode		
		Position 2 is Precision Mode

Panic Recovery Mode

If you feel you have lost control of the aircraft (in any mode), hold the Panic Recovery button/switch. The SAFE® technology will return the aircraft to upright flight.

Always fly at a safe altitude, as Panic Recovery may cause the aircraft to lose altitude while returning to upright flight. Release the Panic Recovery button/switch to turn off Panic mode and return to the current SAFE flight mode with full stick control again.

IMPORTANT: If the aircraft is upside down when the Panic Recovery button/switch is pressed, sufficient altitude may be required for the aircraft to return to upright flight.

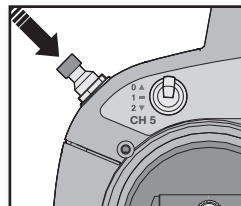

DX4e shown. Panic Button / Switch may vary depending on Transmitter model. See Transmitter setup for more info.

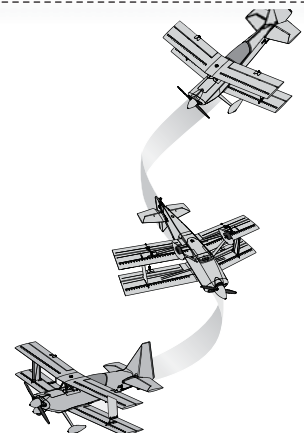

Transmitter Setup for this SAFE® Technology Aircraft

It is extremely important to follow these transmitter setup charts to assign your transmitter switches correctly to operate the flight modes and Panic Recovery correctly.

The installed AR636 receiver has been programmed for operation specifically in this aircraft. The flight modes can be changed in flight using a toggle switch (Gear/Channel 5 Switch).

Use the provided charts to guide you through transmitter setup. Locate your specific transmitter in the chart and follow the numbered setup sequence. The ending results will be:

- **Toggles between flight modes:** Gear/Channel 5 Switch
- **Operates Panic Recovery:** Flap Switch (DX6i)
Trainer/Bind button (DX7S, DX8)
Bind button (DX6, DX9, DX18)
R-Tip (DX10t)

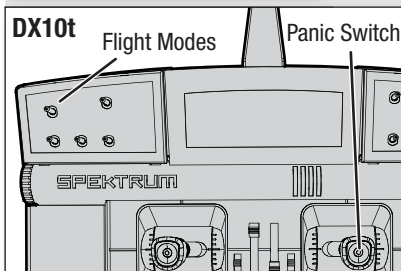
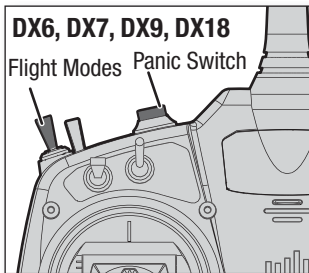
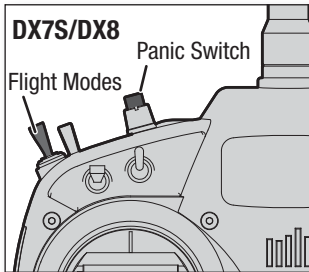
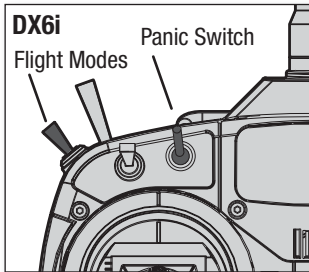

Non-Computerized Transmitter Setup (DX4e and DX5e)	
Before binding a non-computerized transmitter, ensure all servo reversing is set to normal and trim is at center.	

Computerized Transmitter Setup (DX6i) • (DX7S, DX8) • (DX6, DX7, DX9 and DX18) • (DX10t)	
Start all transmitter programming with a blank ACRO model (do a model reset), then name the model.	
Set Dual Rates to:	HIGH 100% LOW 70%
Set Servo Travel to:	100%

DX6i	
1. Go to the SETUP LIST MENU	
2. Set MODEL TYPE: ACRO	
3. Set REVERSE: Gear Channel	
4. Go to ADJUST LIST MENU	
5. Set FLAPS: Norm ↑100, LAND ↓100	
Resulting in:	The Gear switch operates 2 SAFE modes. 0 = 3D Mode (Hi Gain) 1 = Precision mode The Flap switch operates Panic Recovery: Position 0=Off Position 1=On. (not a momentary switch)

DX7S and DX8	
1. Go to the SYSTEM SETUP	
2. Set MODEL TYPE: AIRPLANE	
3. Set SWITCH SELECT: Change all to INH: Then TRAINER: AUX1 Then F-Mode: GEAR	
4. Go to the FUNCTION LIST	
5. Go to SERVO SETUP: Reverse AUX1	
Resulting in:	F-Mode Switch operates the 3 SAFE modes. 0 = 3D Mode (Hi gain) 1 = 3D Mode (Low gain) 2 = Precision mode The Trainer/Bind button operates Panic Recovery

DX6, DX7, DX9, DX18 and DX10t	
1. Go to the SYSTEM SETUP	
2. Set MODEL TYPE: AIRPLANE	
3. Set AIRCRAFT TYPE: NORMAL	
4. Go to CHANNEL ASSIGN: NEXT: Channel Input Config: Set GEAR: B (DX10t: GEAR: A) Set AUX1: I (DX10t: AUX1: R-TIP)	
5. Go to the FUNCTION LIST	
6. Go to SERVO SETUP: Reverse AUX1	
Resulting in:	Switch B (DX10t: A) operates the 3 SAFE modes. 0 = 3D Mode (Hi gain) 1 = 3D Mode (Low gain) 2 = Precision mode The Bind/I button (DX10t: R-TIP) operates Panic Recovery

IMPORTANT: After you set up your model, always rebind the transmitter and receiver to set the desired failsafe positions.

Model Assembly

Landing Gear Installation

1. Install the landing gear assembly (A) on the fuselage and secure in place using 3 screws (B).

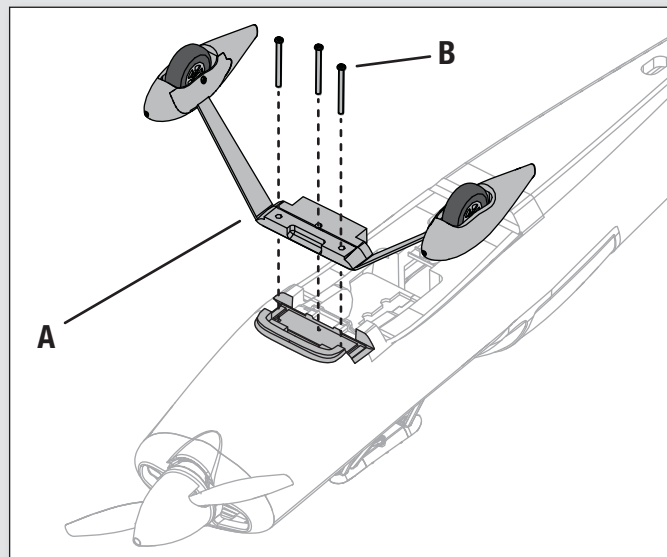

Horizontal Stabilizer Installation

1. Slide the horizontal tail tube (A) into the hole in the rear of the fuselage.
2. Install the 2 piece (left and right) horizontal tail as shown. Ensure the control horn faces down.
3. Secure the 2 piece horizontal tail in place with 4 pieces tape (B) included.
4. Attach the ball link (C) to the elevator control horn's innerer most hole using the included nut and screw.
5. Ensure the elevator and rudder servo arms are in the correct position, then adjust the linkage to center the them.

When needed, disassemble in reverse order.

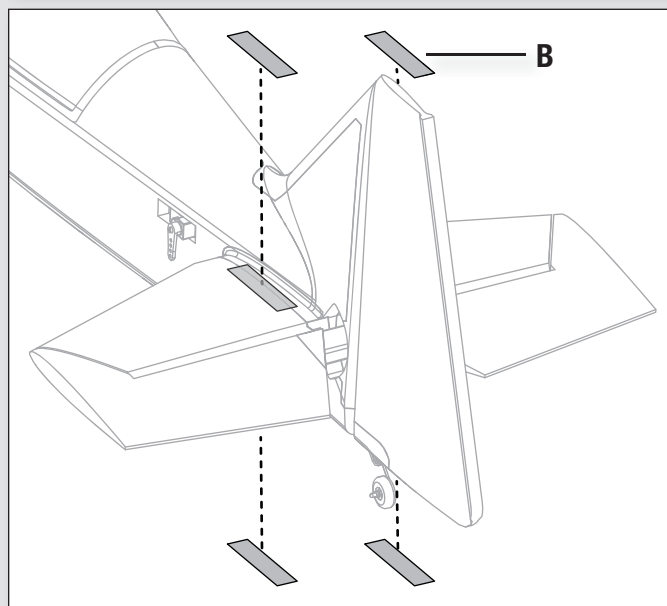
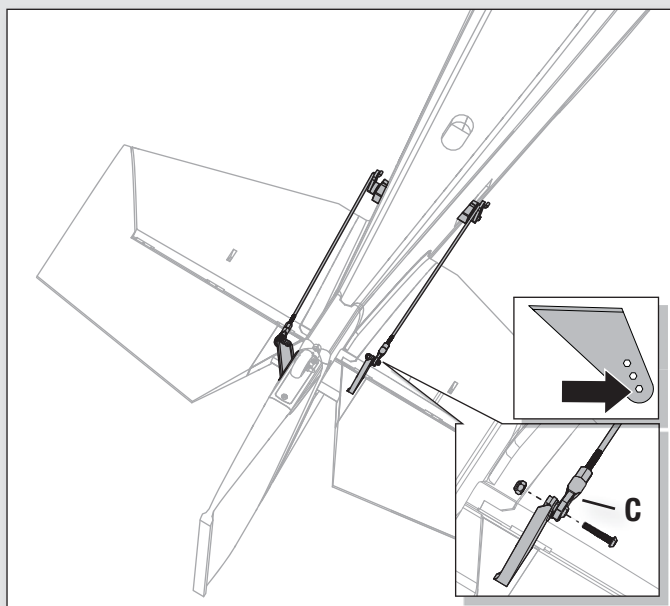
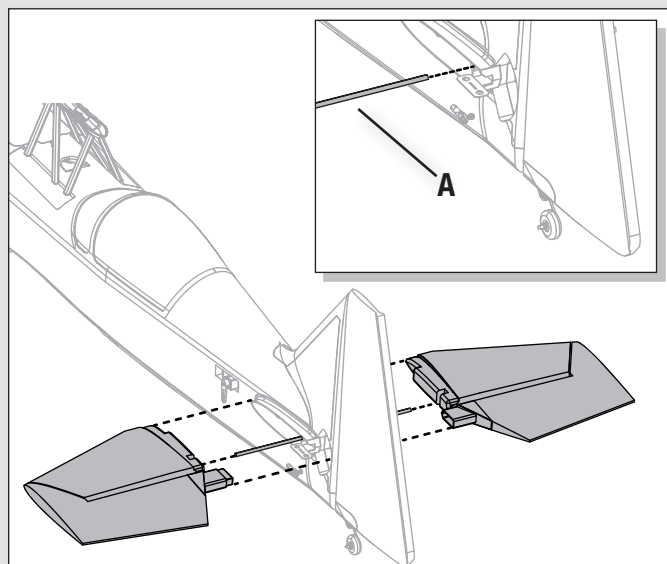

Model Assembly *Continued*

Wing Installation

Bottom Wing Installation

1. Connect the aileron servo connectors (**A**) to the respective connectors in the fuselage. Right aileron servo to port 2 in the receiver and the left aileron into port 6.
2. Align the bottom wing mounting pins with the fuselage mounting plate to attach the bottom wing to the fuselage.
3. Secure the wing in place with the locking pin (**B**). Insert pin and turn 90 degrees to lock in place.

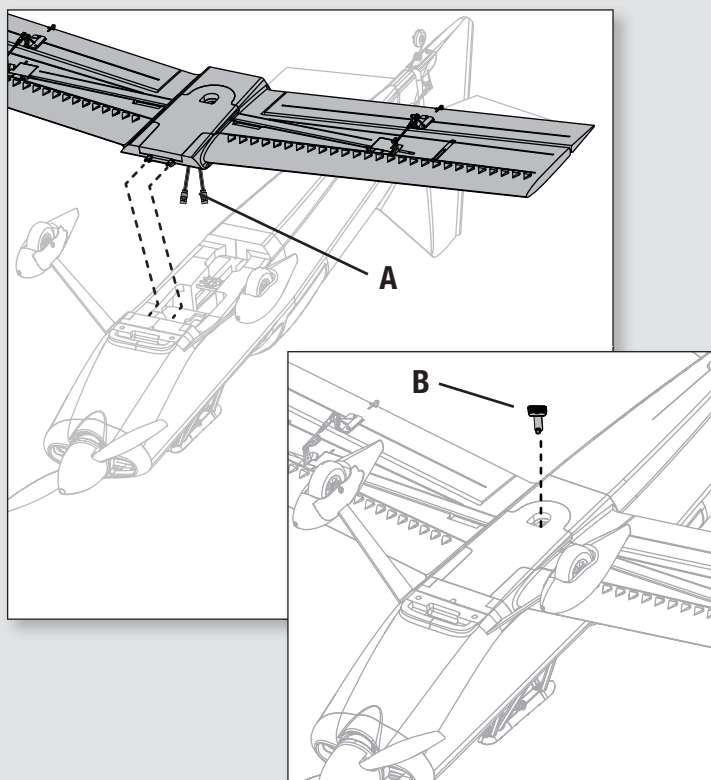

Top Wing Installation

1. Align the top wing with the center mouning post. Slide it into the latch as shown.
2. Secure the wing in place with the locking pin (**C**). Insert pin and turn 90 degrees to lock in place.

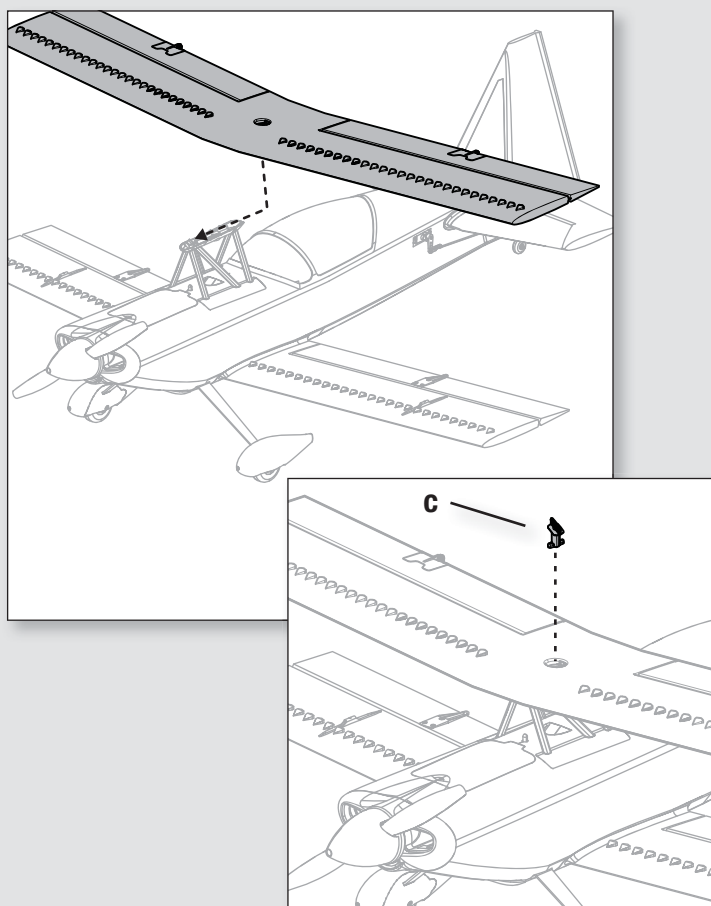

Continued →

Model Assembly *Continued*

3. Slide the left and right wing strut in place, between the upper and lower wings as shown. Ensure that the logo on the strut is facing out.
4. Secure the wing struts to the top and bottom wing with the 4 included pins (A). Ensure that the wing pins are fully seated.
5. Link the upper and lower ailerons by installing the Z-bend end (B) to the lower wing's aileron control horn.
6. Center the lower aileron and adjust the ball link as needed so the top aileron is centered.
7. Secure the ball link end of the pushrod to the top wing control horn with the included screw (C) and nut (D).

When needed, disassemble in reverse order.

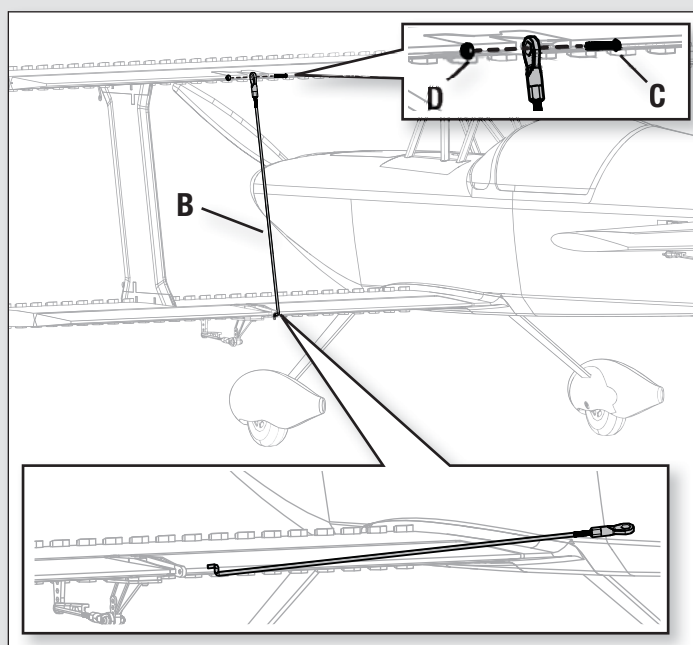
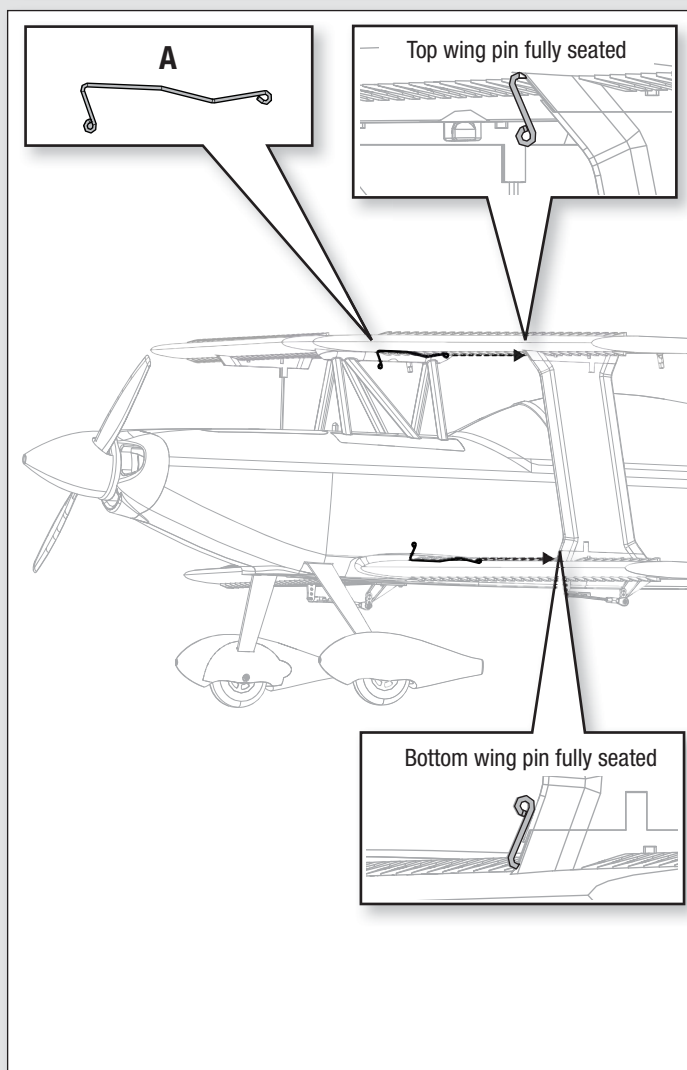
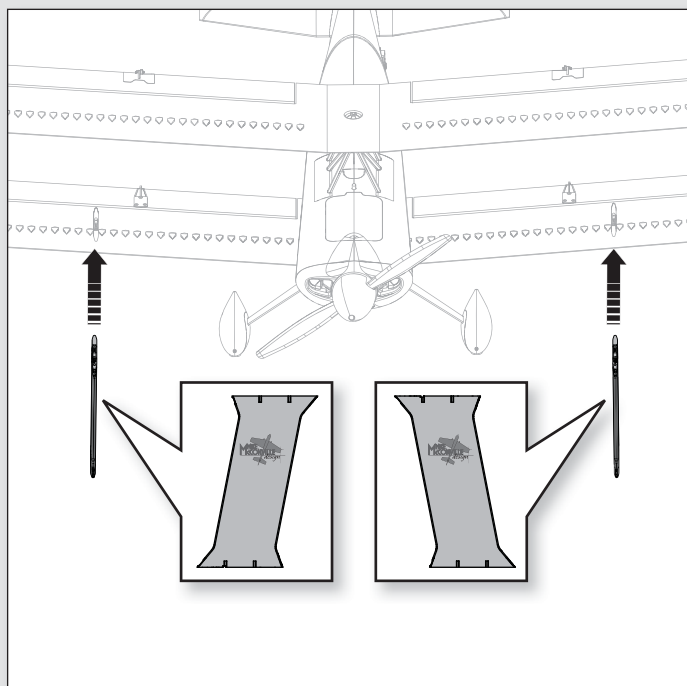

Control Surface Centering

After assembly and transmitter setup, confirm that the control surfaces are centered. If the control surfaces are not centered, mechanically center the control surfaces by adjusting the linkages.

IMPORTANT: DO NOT use sub-trim and trim to center control surfaces. The AS3X system requires sub-trim and trim set at 0.

After binding a transmitter to the aircraft receiver, set the trims and sub-trims to 0, then adjust the linkages to center the control surfaces.

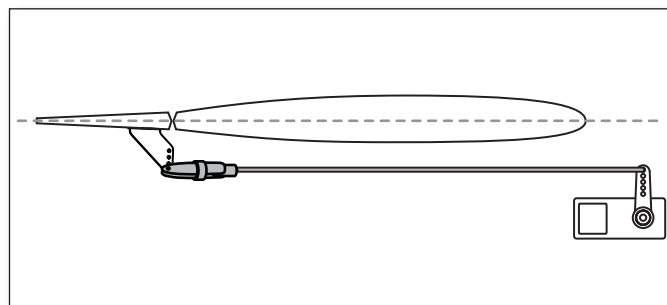

Control Horn and Servo Arm Settings

The table to the right shows the factory settings for the control horns and servo arms. Fly the aircraft at factory settings before making changes.

NOTICE: If control throws are changed from the factory settings, the AR636 gain values may need to be adjusted. Refer to the online Spektrum AR636 manual for adjustment of gain values.

After flying, you may choose to adjust the linkage positions for the desired control response. See the table to the right.

Factory Settings		
	Horns	Arms
Elevator		
Rudder		
Ailerons		

More control throw	Less control throw

Transmitter and Receiver Binding

Binding is the process of programming the receiver to recognize the GUID (Globally Unique Identifier) code of a single specific transmitter. You need to 'bind' your chosen Spektrum™ DSM2®/DSMX® technology equipped aircraft transmitter to the receiver for proper operation.

IMPORTANT: Before binding a transmitter, read the Transmitter Setup section of this manual to ensure that your transmitter is properly programmed for this aircraft.

Binding Procedure

IMPORTANT: The included AR636 receiver has been programmed for operation specifically for this aircraft. Refer to the receiver manual for correct setup if the receiver is replaced or is used in another aircraft.

Read the transmitter instructions for binding to a receiver (location of transmitter's Bind control). **Please visit www.bindnfly.com for a complete list of compatible transmitters.**



CAUTION: When using a Futaba® transmitter with a Spektrum DSM module, you must reverse the throttle channel and rebind. Refer to your Spektrum module manual for binding and failsafe instructions. Refer to your Futaba transmitter manual for instructions on reversing the throttle channel.

1. Make sure the transmitter is powered off.
2. Move the transmitter controls to neutral (flight controls: rudder, elevators and ailerons) or to low positions (throttle, throttle trim).**
3. Install a bind plug in the receiver bind port.
4. Connect the flight battery to the ESC. The ESC will produce a series of sounds. 3 short tones confirm that the LVC is set correctly for the ESC. The orange bind LED on the receiver will begin to flash rapidly.
5. Power on the transmitter while holding the transmitter bind button or switch. Refer to your transmitter's manual for binding.
6. When the receiver binds to the transmitter, the orange bind light on the receiver will turn solid and the ESC will produce ascending tones. The tones indicate the ESC is armed, provided the throttle stick and throttle trim are low enough to trigger arming.

7. Remove the bind plug from the bind port.
8. Safely store the bind plug (some owners attach the bind plug to their transmitter using two-part loops and clips).
9. The receiver should retain the binding instructions received from the transmitter until another binding is done.

* The throttle will not arm if the transmitter's throttle control is not put at the lowest position. If you encounter problems, follow the binding instructions and refer to the transmitter troubleshooting guide for other instructions. If needed, contact the appropriate Horizon Product Support office.

**Failsafe

If the receiver loses transmitter communication, the failsafe will activate. When activated, the airplane controls return to the neutral position established during step 2 of the binding procedure.

Bind Plug Installation

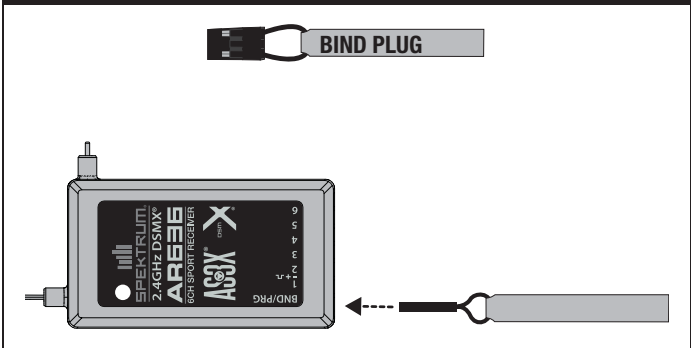

Battery Installation and ESC Arming

Battery Selection

We recommend the E-flite® 2200mAh 11.1V 3S 30C Li-Po battery (EFLB22003S30). Refer to the Optional Parts List for other recommended batteries. If using a battery other than those listed, the battery should be within the range of capacity, dimensions and weight of the E-flite Li-Po battery packs to fit in the fuselage. Be sure the model balances at the recommended CG.

1. Lower the throttle and throttle trim to the lowest settings. Power on the Transmitter, then wait 5 seconds.
2. It is recommended to apply hook and loop tape (A) to the bottom of your battery.
3. Press the battery latch button (B) to remove the battery hatch.
4. Install the fully charged battery (C) in the battery compartment as shown. *See the Adjusting the Center of Gravity instructions for more information.*
5. Make sure the flight battery is secured using the hook and loop straps (D).
6. Connect the battery to the ESC (the ESC is now armed).
7. Keep the aircraft immobile on its landing gear and away from wind or the system will not initialize.
 - The ESC will sound a series of tones (refer to step 6 of the binding instructions for more information).
 - An LED will light on the receiver.
8. Reinstall the battery hatch.

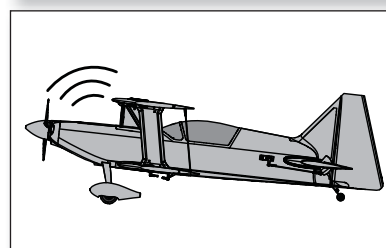
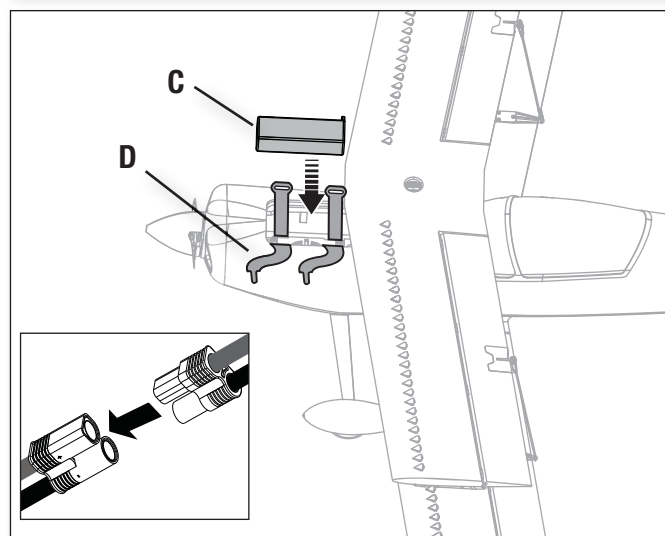
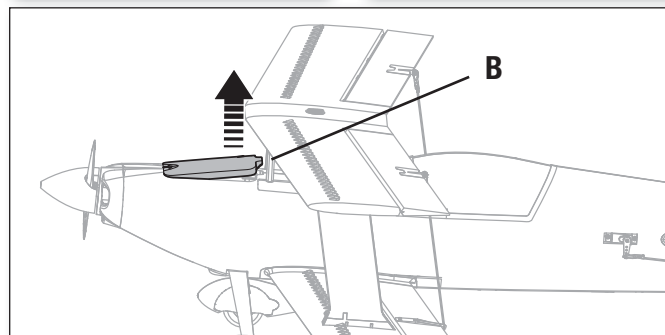
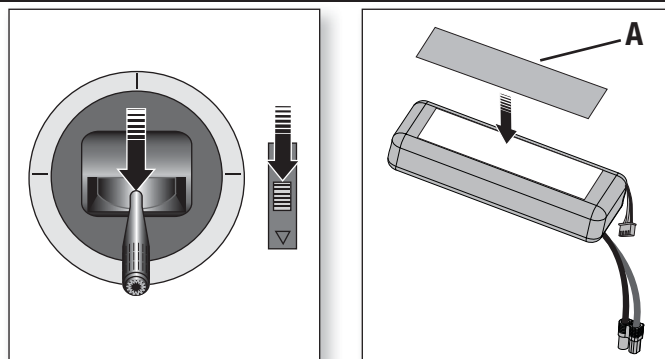

⚠ CAUTION: Always keep hands away from the propeller. When armed, the motor will turn the propeller in response to any throttle movement.

Center of Gravity (CG)

The CG location is measured from the leading edge at the center of the top wing. This CG location has been determined with the recommended Li-Po battery (EFLB22003S30) installed.

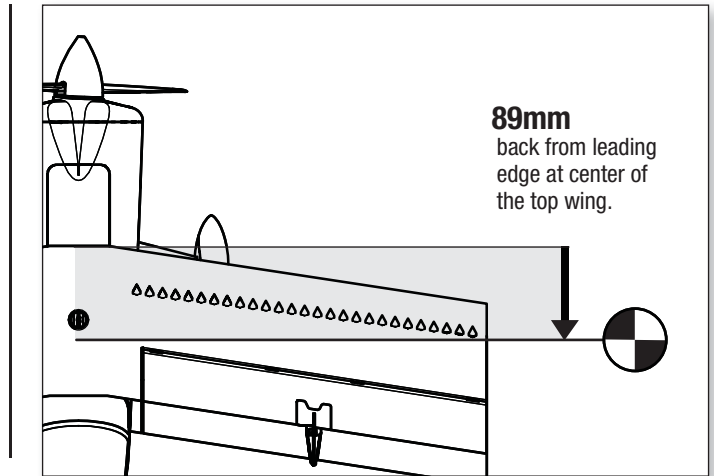

Control Direction Test

Move the controls on the transmitter to make sure the aircraft control surfaces move in the proper direction.

	Transmitter Command	Aircraft Reaction
Elevator	Up Elevator Command	
	Down Elevator Command	
Aileron	Stick Right	
	Stick Left	
Rudder	Stick Right	
	Stick Left	

AS3X Control Direction Test

This test ensures that the AS3X® control system is functioning properly. Assemble the aircraft and bind your transmitter to the receiver before performing this test.

1. Raise the throttle just above 25% and then lower the throttle to activate AS3X.

CAUTION: Keep all body parts, hair and loose clothing away from a moving propeller, as these items could become entangled.

2. Move the entire aircraft as shown, ensure the control surfaces briefly move in the direction indicated in the graphic. If they do not respond as shown, do not fly the aircraft. Refer to the receiver manual for more information.

IMPORTANT: When moving the aircraft the control surfaces will move briefly to react to the movement. They do not move when the aircraft is still.

Once the AS3X system is active, control surfaces may move rapidly. This is normal. AS3X is active until the battery is disconnected.

	Aircraft movement	AS3X Reaction
Elevator		
Aileron		
Rudder		

In Flight Trimming

During your first flight, trim the aircraft for level flight at 3/4 throttle. Make small trim adjustments with your transmitter's trim switches to straighten the aircraft's flight path. After landing, adjust the linkages mechanically to account for trim changes and then reset the trims to neutral. Ensure the aircraft will fly straight and level with no trim or sub-trim.

Only trim the aircraft in Precision flight mode. Do NOT trim in 3D modes.

After adjusting trim **do not touch the control sticks for 2.5 seconds.** This allows the receiver to learn the correct settings to optimize AS3X performance.

Failure to do so could affect flight performance.

For subsequent flights, when the system is powered ON after trim has been set, be sure the transmitter flight mode switch is in Precision Mode until the receiver initializes. Failure to do so may result in a shift of the trim position.

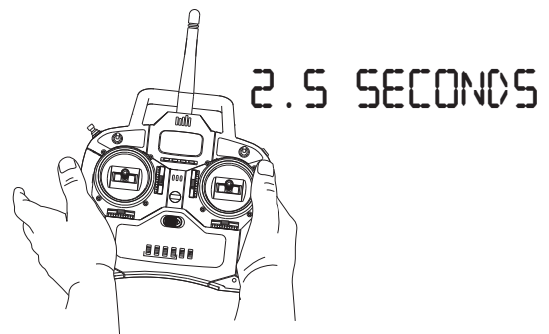

Flying Tips and Repairs

Consult local laws and ordinances before choosing a flying location.

Flying Field

Always choose a wide-open space for flying your aircraft. It is ideal for you to fly at a sanctioned flying field. If you are not flying at an approved site, always avoid flying near houses, trees, wires and buildings. You should also be careful to avoid flying in areas where there are many people, such as busy parks, schoolyards, or soccer fields.

Powering ON Aircraft

After the aircraft has been trimmed in flight, be sure the transmitter Flight mode switch is in Precision Mode until the receiver initializes. Failure to do so may result in a shift of the trim position.

Range Check your Radio System

Before you fly, range check the radio system. Refer to your specific transmitter instruction manual for range test information.

Oscillation

Once the AS3X system is active (after advancing the throttle for the first time), you will normally see the control surfaces react to aircraft movement. In some flight conditions you may see oscillation (the aircraft rocks back and forth on one axis due to overcontrol). If oscillation occurs, decrease airspeed. If oscillation persists, refer to the Troubleshooting Guide for more information.

NOTICE: Fast flight in 3D Mode (High Gain) will cause oscillation and may damage the aircraft.

Takeoff

Place the aircraft in position for takeoff (facing into the wind). Select low rates for first takeoff and gradually increase the throttle to 3/4 to full and steer with the rudder. Pull back gently on the elevator and climb to a comfortable altitude.

Flying

Fly the aircraft and trim it for level flight in Precision Mode at 3/4 throttle. After landing, adjust the linkages mechanically to account for trim changes and then reset the trims to neutral. Ensure the aircraft will fly straight and level with no trim or sub-trim.

Landing

For your first flights with the recommended battery pack (EFLB22003S30), set your transmitter timer or a stopwatch to 4 minutes. After five minutes, land the aircraft. Adjust your timer for longer or shorter flights once you have flown the model. **If at any time the motor pulses, land the aircraft immediately to recharge the flight battery.** See the Low Voltage Cutoff (LVC) section for more details on maximizing battery health and run time.

To land the aircraft, fly the aircraft down to the ground using 1/4 –1/3 throttle to allow for enough energy for a proper flare. The aircraft is easiest to land doing a wheel landing (two point), where the aircraft touches down on the

main landing gear first while the tailwheel is still off the ground. The aircraft can also be landed in a three-point attitude, where all three wheels touch down at the same time. When the aircraft touches down, reduce back pressure on the elevator stick to prevent the plane from becoming airborne again. If landing on grass, it is best to hold full up elevator after touchdown and when taxiing to prevent nosing over.

Once on the ground, avoid sharp turns until the plane has slowed enough to prevent scraping the wingtips.

NOTICE: If a crash is imminent, reduce the throttle and trim fully. Failure to do so could result in extra damage to the airframe, as well as damage to the ESC and motor.

NOTICE: After any impact, always ensure the receiver is secure in the fuselage. If you replace the receiver, install the new receiver in the same orientation as the original receiver or damage may result.

NOTICE: Crash damage is not covered under warranty.

NOTICE: When you are finished flying, never leave the aircraft in direct sunlight or in a hot, enclosed area such as a car. Doing so can damage the foam.

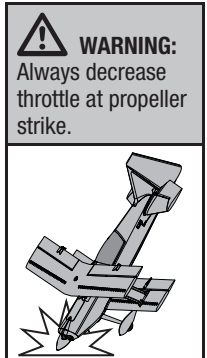

Low Voltage Cutoff (LVC)

When a Li-Po battery is discharged below 3V per cell, it will not hold a charge. The ESC protects the flight battery from over-discharge using Low Voltage Cutoff (LVC). Before the battery charge decreases too much, LVC removes power supplied to the motor. Power to the motor pulses, showing that some battery power is reserved for flight control and safe landing.

Disconnect and remove the Li-Po battery from the aircraft after use to prevent trickle discharge. Charge your Li-Po battery to about half capacity before storage. During storage, make sure the battery charge does not fall below 3V per cell. LVC does not prevent the battery from over-discharge during storage.

NOTICE: Repeated flying to LVC will damage the battery.

Tip: Monitor your aircraft battery's voltage before and after flying by using a Li-Po Cell Voltage Checker (EFLA111, sold separately).

Repairs

Thanks to the Z-Foam™ material in this aircraft, repairs to the foam can be made using virtually any adhesive (hot glue, regular CA, epoxy, etc). When parts are not repairable, see the Replacement Parts List for ordering by item number. For a listing of all replacement and optional parts, refer to the list at the end of this manual.

NOTICE: Use of CA accelerant on your aircraft can damage paint. DO NOT handle the aircraft until accelerant fully dries.

Post Flight Checklist

1	Disconnect the flight battery from the ESC (Required for Safety and battery life).
2	Power OFF the transmitter.
3	Remove the flight battery from the aircraft.
4	Recharge the flight battery.

5	Repair or replace all damaged parts.
6	Store the flight battery apart from the aircraft and monitor the battery charge.
7	Make note of the flight conditions and flight plan results, planning for future flights.

Motor Service

CAUTION: Always disconnect the flight battery before performing motor service.

Disassembly

1. Remove the screw (A), Spinner (B), Propeller nut (C) and washer (D).
2. Remove the propeller (E), spinner backplate (F) backplate (G), and collet (H) from the motor shaft.
3. Pull to remove 2 screws (I) from the cowling (J), and remove the cowling.
4. Remove the 4 screws (K) from the motor mount (L), and remove the motor and motor mount from the fuselage.
5. Disconnect the motor wires from the ESC wires.
6. Remove the 4 screws (M) and motor (N) from the motor mount.

Assembly

Assemble in reverse order.

- Correctly align and connect the motor wire colors with the ESC wires.
- The propeller size numbers (12 x 4) must face out from the motor for correct propeller operation.
- A tool is required to tighten the lock nut on the collet.

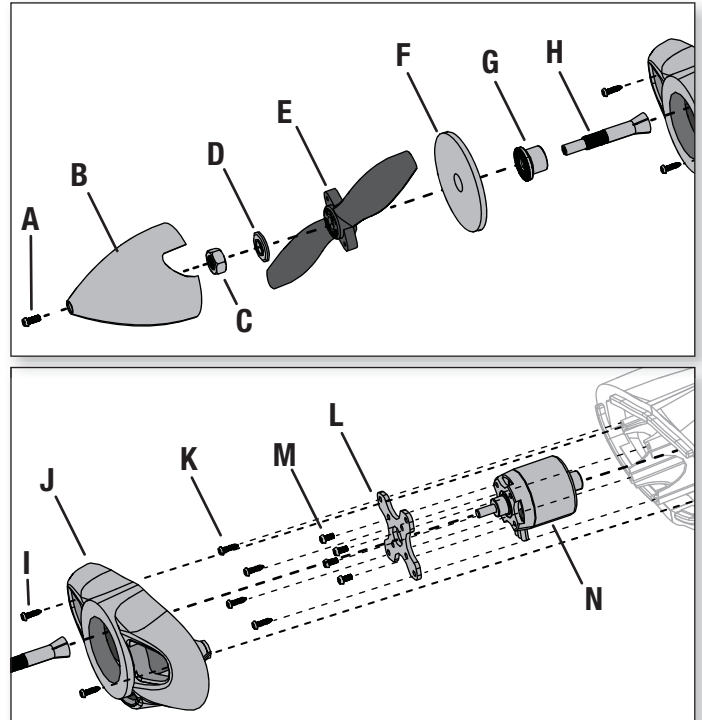

Troubleshooting Guide AS3X

Problem	Possible Cause	Solution
Oscillation	Flying over recommended airspeed	Reduce air speed
	Damaged propeller or spinner	Replace propeller or spinner
	Imbalanced propeller	Balance the propeller. For more information, view John Redman's propeller balancing video at www.horizonhobby.com
	Flight condition variations	Adjust gain to current flight conditions (wind, updrafts, local conditions [elevation, humidity, temperature, etc.]
	Motor vibration	Replace parts or correctly align all parts and tighten fasteners as needed
	Loose receiver	Align and secure receiver in fuselage
	Loose aircraft controls	Tighten or otherwise secure parts (servo, arm, linkage, horn and control surface)
	Worn parts	Adjust gain to compensate for parts wear or replace worn parts (especially propeller, pivot points or servo)
	Irregular servo rotation	Replace servo
	Splines of prop, spinner and back plate do not align	Align the part splines to run smooth at full power
If oscillation persists...	Decrease gain (refer to receiver manual)	
Inconsistent flight performance	Trim is not at neutral	If you adjust trim more than 8 clicks, adjust the clevis to remove trim
	Sub-Trim is not at neutral	No Sub-Trim is allowed. Adjust the servo arm or the clevis
	Receiver was initialized in 3D Mode or aircraft was trimmed in flight while in 3D Mode	Unplug flight battery. Move flight mode switch to Precision Mode and reconnect flight battery
Incorrect response to the AS3X Control Direction Test	Incorrect direction settings in the receiver, which can cause a crash	DO NOT fly. Correct the direction settings (refer to the receiver manual), then fly

Troubleshooting Guide

Problem	Possible Cause	Solution
Aircraft will not respond to throttle but responds to other controls	Throttle not at idle and/or throttle trim too high	Reset controls with throttle stick and throttle trim at lowest setting
	Throttle servo travel is lower than 100%	Make sure throttle servo travel is 100% or greater
	Throttle channel is reversed	Reverse throttle channel on transmitter
	Motor disconnected from ESC	Make sure motor is connected to the ESC
Extra propeller noise or extra vibration	Damaged propeller and spinner, collet or motor	Replace damaged parts
	Propeller is out of balance	Balance or replace propeller
	Prop nut is too loose	Tighten the prop nut
	Spinner is not tight or fully seated in place	Tighten the spinner or remove the spinner and turn it 180 degrees
Reduced flight time or aircraft under-powered	Flight battery charge is low	Completely recharge flight battery
	Propeller installed backwards	Install propeller with numbers facing forward
	Flight battery damaged	Replace flight battery and follow flight battery instructions
	Flight conditions may be too cold	Make sure battery is warm before use
	Battery capacity too low for flight conditions	Replace battery or use a larger capacity battery
Aircraft will not Bind (during binding) to transmitter	Transmitter too near aircraft during binding process	Move powered transmitter a few feet from aircraft, disconnect and reconnect flight battery to aircraft
	Aircraft or transmitter is too close to large metal object, wireless source or another transmitter	Move aircraft and transmitter to another location and attempt binding again
	The bind plug is not installed correctly in the bind port	Install bind plug in bind port and bind the aircraft to the transmitter
	Flight battery/transmitter battery charge is too low	Replace/recharge batteries
	Bind switch or button not held long enough during bind process	Power off transmitter and repeat bind process. Hold transmitter bind button or switch until receiver is bound
	ESC is powered off	Power on the ESC switch
Aircraft will not connect (after binding) to transmitter	Transmitter too near aircraft during connecting process	Move powered transmitter a few feet from aircraft, disconnect and reconnect flight battery to aircraft
	Aircraft or transmitter is too close to large metal object, wireless source or another transmitter	Move aircraft and transmitter to another location and attempt connecting again
	Bind plug left installed in bind port	Rebind transmitter to the aircraft and remove the bind plug before cycling power
	Aircraft bound to different model memory (ModelMatch™ radios only)	Select correct model memory on transmitter
	Flight battery/Transmitter battery charge is too low	Replace/recharge batteries
	Transmitter may have been bound to a different aircraft using different DSM protocol	Bind aircraft to transmitter
	ESC is powered off	Power on the ESC switch
Control surface does not move	Control surface, control horn, linkage or servo damage	Replace or repair damaged parts and adjust controls
	Wire damaged or connections loose	Do a check of wires and connections, connect or replace as needed
	Transmitter is not bound correctly or the incorrect airplanes was selected	Re-bind or select correct airplanes in transmitter
	Flight battery charge is low	Fully recharge flight battery
	BEC (Battery Elimination Circuit) of the ESC is damaged	Replace ESC
	ESC is powered off	Power on the ESC switch
Controls reversed	Transmitter settings are reversed	Perform the Control Direction Test and adjust the controls on transmitter appropriately
Motor power pulses then motor loses power	ESC uses default soft Low Voltage Cutoff (LVC)	Recharge flight battery or replace battery that is no longer performing
	Weather conditions might be too cold	Postpone flight until weather is warmer
	Battery is old, worn out, or damaged	Replace battery
	Battery C rating might be too small	Use recommended battery

AMA National Model Aircraft Safety Code

Effective January 1, 2014

A. GENERAL

A model aircraft is a non-human-carrying aircraft capable of sustained flight in the atmosphere. It may not exceed limitations of this code and is intended exclusively for sport, recreation, education and/or competition. All model flights must be conducted in accordance with this safety code and any additional rules specific to the flying site.

1. Model aircraft will not be flown:
 - (a) In a careless or reckless manner.
 - (b) At a location where model aircraft activities are prohibited.
2. Model aircraft pilots will:
 - (a) Yield the right of way to all man carrying aircraft.
 - (b) See and avoid all aircraft and a spotter must be used when appropriate. (AMA Document #540-D.)
 - (c) Not fly higher than approximately 400 feet above ground level within three (3) miles of an airport, without notifying the airport operator.
 - (d) Not interfere with operations and traffic patterns at any airport, heliport or seaplane base except where there is a mixed use agreement.
 - (e) Not exceed a takeoff weight, including fuel, of 55 pounds unless in compliance with the AMA Large Model Aircraft program. (AMA Document 520-A.)
 - (f) Ensure the aircraft is identified with the name and address or AMA number of the owner on the inside or affixed to the outside of the model aircraft. (This does not apply to model aircraft flown indoors.)
 - (g) Not operate aircraft with metal-blade propellers or with gaseous boosts except for helicopters operated under the provisions of AMA Document #555.
 - (h) Not operate model aircraft while under the influence of alcohol or while using any drug which could adversely affect the pilot's ability to safely control the model.
 - (i) Not operate model aircraft carrying pyrotechnic devices which explode or burn, or any device which propels a projectile or drops any object that creates a hazard to persons or property.

Exceptions:

 - Free Flight fuses or devices that burn producing smoke and are securely attached to the model aircraft during flight.
 - Rocket motors (using solid propellant) up to a G-series size may be used provided they remain attached to the model during flight. Model rockets may be flown in accordance with the National Model Rocketry Safety Code but may not be launched from model aircraft.
 - Officially designated AMA Air Show Teams (AST) are authorized to use devices and practices as defined within the Team AMA Program Document (AMA Document #718).
 - (j) Not operate a turbine-powered aircraft, unless in compliance with the AMA turbine regulations. (AMA Document #510-A).
3. Model aircraft will not be flown in AMA sanctioned events, air shows or model demonstrations unless:
 - (a) The aircraft, control system and pilot skills have successfully demonstrated all maneuvers intended or anticipated prior to the specific event.
 - (b) An inexperienced pilot is assisted by an experienced pilot.
4. When and where required by rule, helmets must be properly worn and fastened. They must be OSHA, DOT, ANSI, SNELL or NOCSAE approved or comply with comparable standards.

B. RADIO CONTROL

1. All pilots shall avoid flying directly over unprotected people, vessels, vehicles or structures and shall avoid endangerment of life and property of others.
2. A successful radio equipment ground-range check in accordance with manufacturer's recommendations will be completed before the first flight of a new or repaired model aircraft.
3. At all flying sites a safety line(s) must be established in front of which all flying takes place (AMA Document #706.)
 - (a) Only personnel associated with flying the model aircraft are allowed at or in front of the safety line.
 - (b) At air shows or demonstrations, a straight safety line must be established.
 - (c) An area away from the safety line must be maintained for spectators.
 - (d) Intentional flying behind the safety line is prohibited.
4. RC model aircraft must use the radio-control frequencies currently allowed by the Federal Communications Commission (FCC). Only individuals properly licensed by the FCC are authorized to operate equipment on Amateur Band frequencies.
5. RC model aircraft will not operate within three (3) miles of any pre-existing flying site without a frequency-management agreement (AMA Documents #922 and #923.)
6. With the exception of events flown under official AMA Competition Regulations, excluding takeoff and landing, no powered model may be flown outdoors closer than 25 feet to any individual, except for the pilot and the pilot's helper(s) located at the flight line.
7. Under no circumstances may a pilot or other person touch a model aircraft in flight while it is still under power, except to divert it from striking an individual.
8. RC night flying requires a lighting system providing the pilot with a clear view of the model's attitude and orientation at all times. Hand-held illumination systems are inadequate for night flying operations.
9. The pilot of a RC model aircraft shall:
 - (a) Maintain control during the entire flight, maintaining visual contact without enhancement other than by corrective lenses prescribed for the pilot.
 - (b) Fly using the assistance of a camera or First-Person View (FPV) only in accordance with the procedures outlined in AMA Document #550.
 - (c) Fly using the assistance of autopilot or stabilization system only in accordance with the procedures outlined in AMA Document #560.

Please see your local or regional modeling association's guidelines for proper, safe operation of your model aircraft.

Limited Warranty

What this Warranty Covers

Horizon Hobby, LLC, (Horizon) warrants to the original purchaser that the product purchased (the "Product") will be free from defects in materials and workmanship at the date of purchase.

What is Not Covered

This warranty is not transferable and does not cover (i) cosmetic damage, (ii) damage due to acts of God, accident, misuse, abuse, negligence, commercial use, or due to improper use, installation, operation or maintenance, (iii) modification of or to any part of the Product, (iv) attempted service by anyone other than a Horizon Hobby authorized service center, (v) Product not purchased from an authorized Horizon dealer, or (vi) Product not compliant with applicable technical regulations, or (vii) use that violates any applicable laws, rules, or regulations.

OTHER THAN THE EXPRESS WARRANTY ABOVE, HORIZON MAKES NO OTHER WARRANTY OR REPRESENTATION, AND HEREBY DISCLAIMS ANY AND ALL IMPLIED WARRANTIES, INCLUDING, WITHOUT LIMITATION, THE IMPLIED WARRANTIES OF NON-INFRINGEMENT, MERCHANTABILITY AND FITNESS FOR A PARTICULAR PURPOSE. THE PURCHASER ACKNOWLEDGES THAT THEY ALONE HAVE DETERMINED THAT THE PRODUCT WILL SUITABLY MEET THE REQUIREMENTS OF THE PURCHASER'S INTENDED USE.

Purchaser's Remedy

Horizon's sole obligation and purchaser's sole and exclusive remedy shall be that Horizon will, at its option, either (i) service, or (ii) replace, any Product determined by Horizon to be defective. Horizon reserves the right to inspect any and all Product(s) involved in a warranty claim. Service or replacement decisions are at the sole discretion of Horizon. Proof of purchase is required for all warranty claims. SERVICE OR REPLACEMENT AS PROVIDED UNDER THIS WARRANTY IS THE PURCHASER'S SOLE AND EXCLUSIVE REMEDY.

Limitation of Liability

HORIZON SHALL NOT BE LIABLE FOR SPECIAL, INDIRECT, INCIDENTAL OR CONSEQUENTIAL DAMAGES, LOSS OF PROFITS OR PRODUCTION OR COMMERCIAL LOSS IN ANY WAY, REGARDLESS OF WHETHER SUCH CLAIM IS BASED IN CONTRACT, WARRANTY, TORT, NEGLIGENCE, STRICT LIABILITY OR ANY OTHER THEORY OF LIABILITY, EVEN IF HORIZON HAS BEEN ADVISED OF THE POSSIBILITY OF SUCH DAMAGES. Further, in no event shall the liability of Horizon exceed the individual price of the Product on which liability is asserted. As Horizon has no control over use, setup, final assembly, modification or misuse, no liability shall be assumed nor accepted for any resulting damage or injury. By the act of use, setup or assembly, the user accepts all resulting liability. If you as the purchaser or user are not prepared to accept the liability associated with the use of the Product, purchaser is advised to return the Product immediately in new and unused condition to the place of purchase.

Law

These terms are governed by Illinois law (without regard to conflict of law principals). This warranty gives you specific legal rights, and you may also have other rights which vary from state to state. Horizon reserves the right to change or modify this warranty at any time without notice.

WARRANTY SERVICES

Questions, Assistance, and Services

Your local hobby store and/or place of purchase cannot provide warranty support or service. Once assembly, setup or use of the Product has been started, you must contact your local distributor or Horizon directly. This will enable Horizon to better answer your questions and service you in the event that you may need any assistance. For questions or assistance, please visit our website at www.horizonhobby.com, submit a Product Support Inquiry, or call the toll free telephone number referenced in the Warranty and Service Contact Information section to speak with a Product Support representative.

Inspection or Services

If this Product needs to be inspected or serviced and is compliant in the country you live and use the Product in, please use the Horizon Online Service Request submission process found on our website or call Horizon to obtain a Return Merchandise Authorization (RMA) number. Pack the Product securely using a shipping carton. Please note that original boxes may be included, but are not designed to withstand the rigors of shipping without additional

protection. Ship via a carrier that provides tracking and insurance for lost or damaged parcels, as Horizon is not responsible for merchandise until it arrives and is accepted at our facility. An Online Service Request is available at http://www.horizonhobby.com/content/_service-center_render-service-center. If you do not have internet access, please contact Horizon Product Support to obtain a RMA number along with instructions for submitting your product for service. When calling Horizon, you will be asked to provide your complete name, street address, email address and phone number where you can be reached during business hours. When sending product into Horizon, please include your RMA number, a list of the included items, and a brief summary of the problem. A copy of your original sales receipt must be included for warranty consideration. Be sure your name, address, and RMA number are clearly written on the outside of the shipping carton.

NOTICE: Do not ship LiPo batteries to Horizon. If you have any issue with a LiPo battery, please contact the appropriate Horizon Product Support office.

Warranty Requirements

For Warranty consideration, you must include your original sales receipt verifying the proof-of-purchase date. Provided warranty conditions have been met, your Product will be serviced or replaced free of charge. Service or replacement decisions are at the sole discretion of Horizon.

Non-Warranty Service

Should your service not be covered by warranty, service will be completed and payment will be required without notification or estimate of the expense unless the expense exceeds 50% of the retail purchase cost. By submitting the item for service you are agreeing to payment of the service without notification. Service estimates are available upon request. You must include this request with your item submitted for service. Non-warranty service estimates will be billed a minimum of ½ hour of labor. In addition you will be billed for return freight. Horizon accepts money orders and cashier's checks, as well as Visa, MasterCard, American Express, and Discover cards. By submitting any item to Horizon for service, you are agreeing to Horizon's Terms and Conditions found on our website http://www.horizonhobby.com/content/_service-center_render-service-center.

ATTENTION: Horizon service is limited to Product compliant in the country of use and ownership. If received, a non-compliant Product will not be serviced. Further, the sender will be responsible for arranging return shipment of the un-serviced Product, through a carrier of the sender's choice and at the sender's expense. Horizon will hold non-compliant Product for a period of 60 days from notification, after which it will be discarded.

Contact Information

Country of Purchase	Horizon Hobby	Phone Number/Email Address	Address
United States of America	Horizon Service Center (Repairs and Repair Requests)	servicecenter.horizonhobby.com/ RequestForm/	4105 Fieldstone Rd Champaign, Illinois, 61822 USA
	Horizon Product Support (Product Technical Assistance)	www.quickbase.com/db/ bghj7ey8c?a=GenNewRecord 888-959-2305	
	Sales	sales@horizonhobby.com 888-959-2305	
United Kingdom	Service/Parts/Sales: Horizon Hobby Limited	sales@horizonhobby.co.uk +44 (0) 1279 641 097	Units 1–4 , Ployters Rd, Staple Tye Harlow, Essex, CM18 7NS, United Kingdom
Germany	Horizon Technischer Service Sales: Horizon Hobby GmbH	service@horizonhobby.de +49 (0) 4121 2655 100	Christian-Junge-Straße 1 25337 Elmshorn, Germany
France	Service/Parts/Sales: Horizon Hobby SAS	infofrance@horizonhobby.com +33 (0) 1 60 18 34 90	11 Rue Georges Charpak 77127 Lieusaint, France
China	Service/Parts/Sales: Horizon Hobby – China	info@horizonhobby.com.cn +86 (021) 5180 9868	Room 506, No. 97 Changshou Rd. Shanghai, China 200060

FCC Information

Operation is subject to the following two conditions: (1) This device may not cause harmful interference, and (2) this device must accept any interference received, including interference that may cause undesired operation.

This product contains a radio transmitter with wireless technology which has been tested and found to be compliant with the applicable regulations governing a radio transmitter in the 2.400GHz to 2.4835GHz frequency range.



CAUTION: Changes or modifications not expressly approved by the party responsible for compliance could void the user's authority to operate the equipment.

IC Information

This device complies with Industry Canada licence-exempt RSS standard(s). Operation is subject to the following two conditions: (1) this device may not

cause interference, and (2) this device must accept any interference, including interference that may cause undesired operation of the device.

Compliance Information for the European Union



EFL Ultimate² BNF (EFL4350)

EU Compliance Statement: Horizon Hobby, LLC hereby declares that this product is in compliance with the essential requirements and other relevant provisions of the R&TTE and EMC Directive.

A copy of the EU Declaration of Conformity is available online at: <http://www.horizonhobby.com/content/support-render-compliance>.

Instructions for disposal of WEEE by users in the European Union



This product must not be disposed of with other waste. Instead, it is the user's responsibility to dispose of their waste equipment by handing it over to a designated collections point for the recycling of waste electrical and electronic equipment. The separate collection and recycling of your waste equipment at the time of disposal will help to conserve natural resources and ensure that it is recycled in a manner that protects human health and the environment. For more information about where you can drop off your waste equipment for recycling, please contact your local city office, your household waste disposal service or where you purchased the product.

Replacement Parts • Ersatzteile • Pièces de rechange • Pezzi di ricambio

Part # Nummer Numéro Codice	Description	Beschreibung	Description	Descrizione
EFL108001	Painted Fuselage: Ultimate 2	Ultimate 2: Rumpf lackiert	Ultimate 2 - Fuselage peint	Fusoliera verniciata: Ultimate 2
EFL108002	Top Wing Set: Ultimate 2	Ultimate 2: Tragflächenset oben	Ultimate 2 - Aile supérieure	Set ala superiore: Ultimate 2
EFL108003	Bottom Wing Set: Ultimate 2	Ultimate 2: Tragflächenset unten	Ultimate 2 - Aile inférieure	Set ala inferiore: Ultimate 2
EFL108004	Horizontal Stab set: Ultimate 2	Ultimate 2: Höhenleitwerkset	Ultimate 2 - Stabilisateur	Set impennaggio orizzontale: Ultimate 2
EFL108005	Rudder: Ultimate 2	Ultimate 2: Seitenleitwerk	Ultimate 2 - Dérive	Direzionale: Ultimate 2
EFL108006	Cowl: Ultimate 2	Ultimate 2: Motorhaube	Ultimate 2 - Capot	Capottina : Ultimate 2
EFL108007	Landing gear set: Ultimate 2	Ultimate 2: Fahrwerk	Ultimate 2 - Train d'atterrissage	Set carrello: Ultimate 2
EFL108009	Strut Set: Ultimate 2	Ultimate 2: Strebenset	Ultimate 2 - Haubans	Set montanti: Ultimate 2
EFL108010	Strut Wire Clips (4): Ultimate 2	Ultimate 2: Strebenclips	Ultimate 2 - Clips de haubans	Clips per fili montanti (4): Ultimate 2
EFL108011	Pushrod Set: Ultimate 2	Ultimate 2: Gestängeset	Ultimate 2 - Tringleries	Set aste comandi: Ultimate 2
EFL108012	Control Horn Set: Ultimate 2	Ultimate 2: Ruderhornset	Ultimate 2 - Guignols	Set squadrette: Ultimate 2
EFL108013	Wing Thumb Screws: Ultimate 2	Ultimate 2: Tragflächenschrauben	Ultimate 2 - Vis de fixation d'aile	Viti ala: Ultimate 2
EFL108014	Decal Sheet: Ultimate 2	Ultimate 2: Dekorbogen	Ultimate 2 - Planche de décoration	Foglio decorazioni adesive: Ultimate 2
EFL108015	Spinner w/screw: Ultimate2	Ultimate 2: Spinner mit Schraube	Ultimate 2 - Cône avec vis	Ogiva con vite: Ultimate2
EFL108016	Motor Mount: Ultimate 2	Ultimate 2: Motorhalter	Ultimate 2 - Support moteur	Supporto motore: Ultimate 2
EFL108017	Prop Adapter: Ultimate 2	Ultimate 2: Propelleradapter	Ultimate 2 - Adaptateur d'hélice	Adattatore elica: Ultimate 2
EFLM108018	Motor 1300 Kv: Ultimate 2	Ultimate 2: Motor 1300 Kv	Ultimate 2 - Moteur 10 1300Kv	Motore 1300 Kv: Ultimate 2
EFLM108019	Motor Shaft: Ultimate 2	Ultimate 2: Motorwelle	Ultimate 2 - Axe moteur	Albero motore: Ultimate 2
EFLP1240UE	Propeller: 12 x 4	Propeller 12 x4	Hélice 12x4	Elica: 12 x 4
EFLA1040U	40A ESC: Ultimate 2	Ultimate 2: 40A ESC Regler	Ultimate 2 - Contrôleur 40A	ESC 40A: Ultimate 2
EFLR7156	13G Digital Servo	13 g Digital Servo	Servo digital 13g	Servo digitale 13g
EFL108020	Stab Joiner: Ultimate 2	Ultimate 2: Leitwerksverbinder	Ultimate 2 - Tige de liaison de stabilisateur	Sistema unione stabilizzatore: Ultimate 2

Optional Parts • Optionale Bauteile • Pièces optionnelles • Pezzi opzionali

Part # Nummer Numéro Codice	Description	Beschreibung	Description	Descrizione
EFLA250	Park Flyer Tool Assortment, 5 pc	Park Flyer Werkzeugsortiment, 5 teilig	Assortiment d'outils park flyer, 5pc	Park Flyer assortimento attrezzi, 5 pc
EFLAEC302	EC3 Battery Connector, Female (2)	EC3 Akkukabel, Buchse (2)	Prise EC3 femelle (2pc)	EC3 Connettore femmina x batteria (2)
EFLAEC303	EC3 Device/Battery Connector, Male/Female	EC3 Kabelsatz, Stecker/Buchse	Prise EC3 male/femelle	EC3 Connettore batteria maschio/femmina
EFLB32003S30	11.1V 3S 30C 3200MAH Li-Po	11.1V 3S 30C 3200mAh LiPo	11.1V 3S 30C 3200MAH Li-Po	11.1V 3S 30C 3200MAH Li-Po
EFLC3025	Celectra 80W AC/DC Multi-Chemistry Battery Charger	Celectra 80 W AC/DC Multi-Chemistry-Batterieladegerät	Chargeur de batterie AC/DC Celectra 80 W multi-types	Caricabatterie per batteria multichimica 80 W c.a./c.c.
EFLC3020	200W DC multi-chemistry battery charger	200W DC Multi-Batterie Ladegerät - EU	Chargeur multiple DC 200W	200W DC Caricabatterie universale
EFLC4010	Celectra 15VDC 250W Power Supply	Celectra 15 V DC 250-W-Netzstecker	Alimentation Celectra CC 15 V 250 W	Alimentatore Celectra 15V c.c., 250 W
DYNC2010CA	Prophet Sport Plus 50W AC DC Charger	Dynamite Ladegerät Prophet Sport Plus 50W AC/DC EU	Chargeur Prophet Sport Plus 50W AC DC	Caricabatterie Prophet Sport Plus 50W AC DC
SPMA380	AS3X Programming Cable - Audio Interface	Spektrum Audio-Interface AS3X Empfänger Programmierkabel	Câble de programmation audio AS3X pour smartphone	Cavo di programmazione AS3X - Interfaccia audio
SPMA3065	AS3X Programming Cable - USB Interface	Spektrum USB-Interface AS3X Empfänger Programmierkabel	Câble de programmation USB AS3X pour PC	Cavo di programmazione AS3X - Interfaccia USB
EFLA111	Li-Po Cell Voltage Checker	Li-Po Cell Voltage Checker	Testeur de tension d'éléments Li-Po	Voltmetro verifica batterie LiPo
DYN1405	Li-Po Charge Protection Bag, Large	Dynamite LiPoCharge Protection Bag groß	Sac de charge Li-Po, grand modèle.	Sacchetto grande di protezione per carica LiPo
DYN1400	Li-Po Charge Protection Bag, Small	Dynamite LiPoCharge Protection Bag klein	Sac de charge Li-Po, petit modèle	Sacchetto piccolo di protezione per carica LiPo
	DX6i DSMX 6-Channel Transmitter	Spektrum DX6i DSMX 6-Kanal Sender	Emetteur DX6i DSMX 6 voies	DX6i DSMX Trasmettitore 6 canali
	DX6 DSMX 6-Channel Transmitter	Spektrum DX6 DSMX 6-Kanal Sender	Emetteur DX6 DSMX 6 voies	DX6 DSMX Trasmettitore 6 canali
	DX7s DSMX 7-Channel Transmitter	Spektrum DX7s DSMX 7 Kanal Sender	Emetteur DX7s DSMX 7 voies	DX7s DSMX Trasmettitore 7 canali
	DX7 DSMX 7-Channel Transmitter	Spektrum DX7 DSMX 7 Kanal Sender	Emetteur DX7 DSMX 7 voies	DX7 DSMX Trasmettitore 7 canali
	DX8 DSMX 8-Channel Transmitter	Spektrum DX8 DSMX 8 Kanal Sender	Emetteur DX8 DSMX 8 voies	DX8 DSMX Trasmettitore 8 canali
	DX9 DSMX 9-Channel Transmitter	Spektrum DX9 DSMX 9 Kanal Sender	Emetteur DX9 DSMX 9 voies	DX9 DSMX Trasmettitore 9 canali
	DX18 DSMX 18-Channel Transmitter	Spektrum DX18 DSMX 18 Kanal Sender	Emetteur DX18 DSMX 18 voies	DX18 DSMX Trasmettitore 18 canali



Ultimate²

© 2015 Horizon Hobby, LLC.

E-flite, AS3X, DSM, DSM2, DSMX, the DSMX logo, Bind-N-Fly, Z-Foam, ModelMatch, EC3, Celectra and the Horizon Hobby logo are trademarks or registered trademarks of Horizon Hobby, LLC.

The Spektrum trademark is used with permission of Bachmann Industries, Inc.

Futaba is a registered trademark of Futaba Denshi Kogyo Kabushiki Kaisha Corporation of Japan.

All other trademarks, service marks and logos are property of their respective owners.

Patents pending.

<http://www.e-fliterc.com/>