

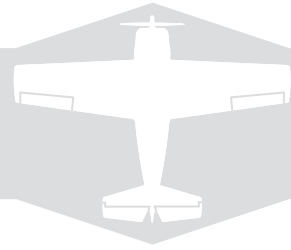

parkzone®

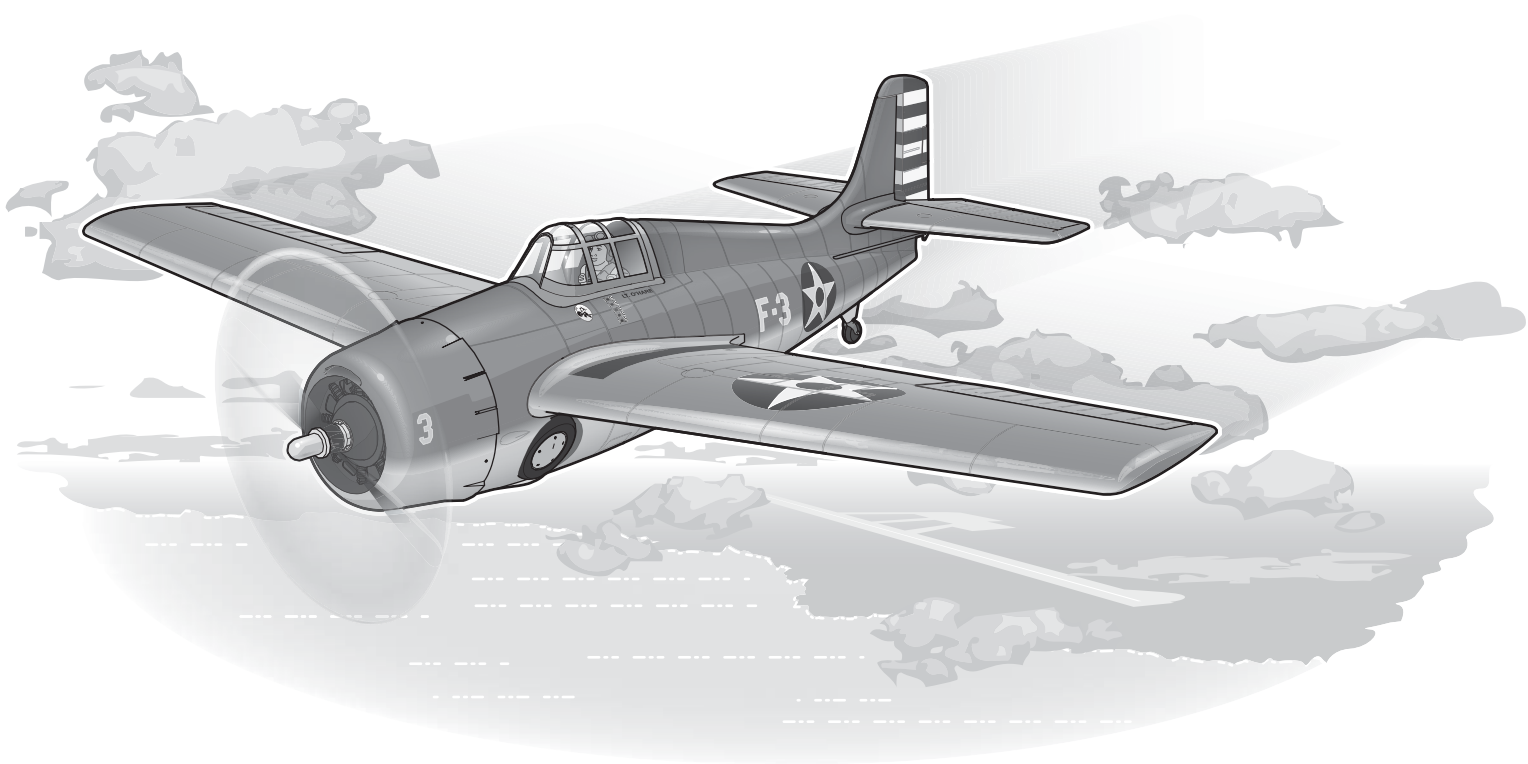

# *F4F Wildcat*



*Instruction Manual / Bedienungsanleitung  
Manuel d'utilisation / Manuale di Istruzioni*



PKZ1950

PKZ1975

**NOTICE**

All instructions, warranties and other collateral documents are subject to change at the sole discretion of Horizon Hobby, LLC. For up-to-date product literature, visit [www.horizonhobby.com](http://www.horizonhobby.com) and click on the support tab for this product.

**Meaning of Special Language:**

The following terms are used throughout the product literature to indicate various levels of potential harm when operating this product:

**WARNING:** Procedures, which if not properly followed, create the probability of property damage, collateral damage, and serious injury OR create a high probability of superficial injury.

**CAUTION:** Procedures, which if not properly followed, create the probability of physical property damage AND a possibility of serious injury.

**NOTICE:** Procedures, which if not properly followed, create a possibility of physical property damage AND little or no possibility of injury.

 **WARNING:** Read the ENTIRE instruction manual to become familiar with the features of the product before operating. Failure to operate the product correctly can result in damage to the product, personal property and cause serious injury.

This is a sophisticated hobby product. It must be operated with caution and common sense and requires some basic mechanical ability. Failure to operate this Product in a safe and responsible manner could result in injury or damage to the product or other property. This product is not intended for use by children without direct adult supervision. Do not use with incompatible components or alter this product in any way outside of the instructions provided by Horizon Hobby, LLC. This manual contains instructions for safety, operation and maintenance. It is essential to read and follow all the instructions and warnings in the manual, prior to assembly, setup or use, in order to operate correctly and avoid damage or serious injury.

**WARNING AGAINST COUNTERFEIT PRODUCTS:** If you ever need to replace your Spektrum receiver found in a Horizon Hobby product, always purchase from Horizon Hobby, LLC or a Horizon Hobby authorized dealer to ensure authentic high-quality Spektrum product. Horizon Hobby, LLC disclaims all support and warranty with regards, but not limited to, compatibility and performance of counterfeit products or products claiming compatibility with DSM or Spektrum technology.

**Age Recommendation: Not for children under 14 years. This is not a toy.**

**Safety Precautions and Warnings**

As the user of this product, you are solely responsible for operating in a manner that does not endanger yourself and others or result in damage to the product or the property of others.

- Always keep a safe distance in all directions around your model to avoid collisions or injury. This model is controlled by a radio signal subject to interference from many sources outside your control. Interference can cause momentary loss of control
- Always operate your model in open spaces away from full-size vehicles, traffic and people.
- Always carefully follow the directions and warnings for this and any optional support equipment (chargers, rechargeable battery packs, etc.).
- Always keep all chemicals, small parts and anything electrical out of the reach of children.
- Always avoid water exposure to all equipment not specifically designed and protected for this purpose. Moisture causes damage to electronics.

- Never place any portion of the model in your mouth as it could cause serious injury or even death.
- Never operate your model with low transmitter batteries.
- Always keep aircraft in sight and under control.
- Always use fully charged batteries.
- Always keep transmitter powered on while aircraft is powered.
- Always remove batteries before disassembly.
- Always keep moving parts clean.
- Always keep parts dry.
- Always let parts cool after use before touching.
- Always remove batteries after use.
- Always ensure failsafe is properly set before flying.
- Never operate aircraft with damaged wiring.
- Never touch moving parts.

**Battery Charging Warnings**

 **CAUTION:** All instructions and warnings must be followed exactly. Mishandling of Li-Po batteries can result in a fire, personal injury, and/or property damage.

- **NEVER LEAVE CHARGING BATTERIES UNATTENDED.**
- **NEVER CHARGE BATTERIES OVERNIGHT.**
- By handling, charging or using the included Li-Po battery, you assume all risks associated with lithium batteries.
- If at any time the battery begins to balloon or swell, discontinue use immediately. If charging or discharging, discontinue and disconnect. Continuing to use, charge or discharge a battery that is ballooning or swelling can result in fire.
- Always store the battery at room temperature in a dry area for best results.
- Always transport or temporarily store the battery in a temperature range of 40–120° F (5–49° C). Do not store the battery or aircraft in a car or direct sunlight. If stored in a hot car, the battery can be damaged or even catch fire.
- Always charge batteries away from flammable materials.
- Always inspect the battery before charging and never charge damaged batteries.
- Always disconnect the battery after charging, and let the charger cool between charges.
- Always constantly monitor the temperature of the battery pack while charging.
- **ONLY USE A CHARGER SPECIFICALLY DESIGNED TO CHARGE LI-PO BATTERIES.** Failure to charge the battery with a compatible charger may cause fire resulting in personal injury and/or property damage
- Never discharge Li-Po cells to below 3V under load.
- Never cover warning labels with hook and loop strips.
- Never leave charging batteries unattended.
- Never charge batteries outside recommended levels.
- Never attempt to dismantle or alter the charger.
- Never allow minors to charge battery packs.
- Never charge batteries in extremely hot or cold places (recommended between 40–120° F or 5–49° C) or place in direct sunlight.

## Table of Contents

Battery Charging.....	4	Trimming the Aircraft .....	11
Assembly.....	4	Service of Power Components.....	12
Control Horn and Servo Settings .....	5	Troubleshooting Guide .....	13
Receiver and Battery Selection and Installation .....	6	Limited Warranty .....	14
Transmitter and Receiver Binding / Switching ON and OFF SAFE Select .....	7	Warranty and Service Contact Information .....	14
SAFE® Select Switch Designation.....	8	FCC Information.....	15
High/Low Rate Switch (Dual Rates).....	8	IC Information.....	15
Control Direction Test.....	8	Compliance Information for the European Union.....	15
Center of Gravity (CG) .....	9	Replacement parts.....	61
Flying Tips and Repairs.....	9	Optional parts.....	61
Flying .....	10		
Post Flight.....	11		

## Box Contents

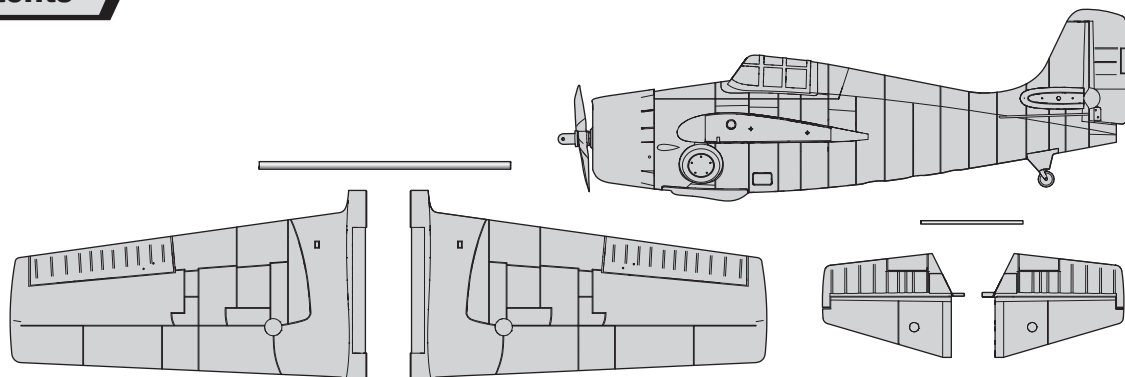

## Specifications

PNP		BNF
Installed	<b>Motor</b> 480 Brushless Outrunner: 960Kv (PKZ4416)	Installed
Installed	<b>Servos</b> (2) Ailerons (PKZ1081), (2) Rudder and Elevator (PKZ1080)	Installed
Installed	<b>ESC</b> 18-Amp Brushless ESC (PKZ1814)	Installed
Required to complete	<b>Recommended Receiver</b> Spektrum™ AR636 6-Channel AS3X® Sport Receiver (SPMAR636)	Installed
Required to complete	<b>Recommended Battery</b> 11.1V 3S 1300mAh 25C Li-Po (PKZ1033)	Required to complete
Required to complete	<b>Recommended Battery Charger</b> 2- to 3-Cell DC Li-Po Balancing Charger (PKZ1040)	Required to complete
Required to complete	<b>Recommended Transmitter</b> Full-Range 4-Channel (or more) 2.4GHz with Spektrum™ DSM2®/DSMX® technology.	Required to complete

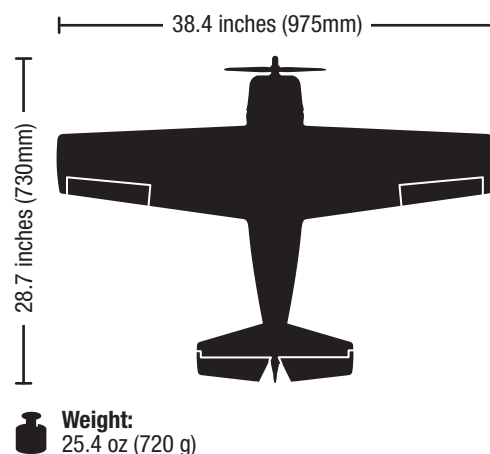

Preflight Checklist		✓
1. Find a safe and open area.		
2. Charge flight battery.		
3. Install fully charged flight battery in aircraft.		
4. Make sure linkages move freely.		
5. Perform Control Direction Test.		
6. Perform SAFE Control Direction Test.		
7. Perform a Range Check.		
8. Plan flight for flying field conditions.		
9. Set a flight timer for 8-10 Min.		
10. Have fun!		

Quick Start Reference		
Dual Rates	High	Low
	100%	70%
CG	<b>47mm</b> 1 <sup>7</sup> / <sub>8</sub> inches back from the leading edge of the wing at the root, +/- 1 <sup>1</sup> / <sub>8</sub> inch (3mm)	
Flight Timer Setting	First Flight 5 Min.	

If you own this product, you may be required to register with the FAA.

For up-to-date information on how to register with the FAA, please visit <https://registermyuas.faa.gov/>.

For additional assistance on regulations and guidance on UAS usage, visit [knowbeforeyoufly.org/](http://knowbeforeyoufly.org/).

To register your product online, visit [www.parkzone.com](http://www.parkzone.com)

## Battery Charging

Refer to the charging warnings. It is recommended to charge the battery while you inspect the aircraft. The flight battery will be required to confirm proper aircraft operation in future steps.

### Battery Charging Process

**NOTICE:** Charge only batteries that are cool to the touch and are not damaged. Look at the battery to make sure it is not damaged e.g., swollen, bent, broken or punctured.

1. Attach the input cord of the charger to the appropriate power supply (12V accessory outlet).
2. When the Li-Po charger has been correctly powered up, there will be an approximate 3-second delay, then an audible “beep” and the green (ready) LED will flash.
3. Turn the control on the Amps selector so the arrow points to the charging rate required for the battery (the included 2200mAh Li-Po battery will charge at 2.0 amps, which is 1C). DO NOT change the charge rate once the battery begins charging.
4. Move the cell selector switch to 3-cell for your battery.
5. Connect the Balancing Lead of the Battery to the 3-cell (it has 4 pins) charger port.
6. The green and red LEDs may flash during the charging process when the charger is balancing cells. Balancing prolongs the life of the battery.
7. When the battery is fully charged, there will be an audible beep for approximately 3 seconds and the green LED will glow solid. Attempting to charge an over-discharged battery will cause the charger to repeatedly flash and beep, indicating an error has occurred.
8. Always disconnect the battery from the charger immediately upon completion of charging.

**⚠ CAUTION:** Never exceed the recommended charge rate, overcharging a battery can cause a fire.

**⚠ CAUTION:** Only use a charger specifically designed to charge a Li-Po battery. Failure to do so could result in fire causing injury or property damage.

**⚠ CAUTION:** The balance connector must be inserted into the correct port of your charger prior to charging.

## Assembly

### Wing Installation

1. Insert the wing tube (A) into the round hole of the wing slot of the fuselage.
2. Slide the right wing onto the wing tube.
3. Move the wing on the tube into the slot in the fuselage while feeding the aileron control connector through the hole in the fuselage into the receiver compartment.
4. Secure the wing in the fuselage using a screw.
5. Repeat Steps 1–4 for the other wing.
6. Connect the left and right aileron servos to the pre-installed Y-harness. The left and right aileron servos can be connected to either side of the Y-harness.

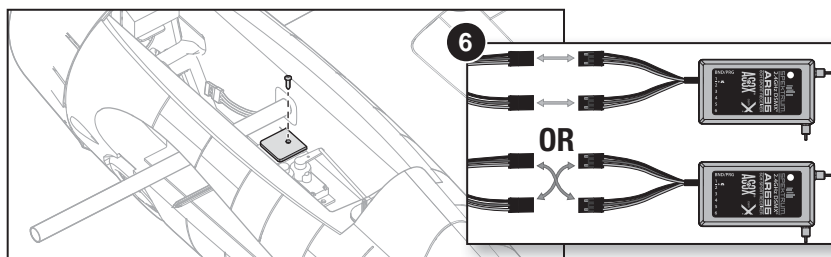
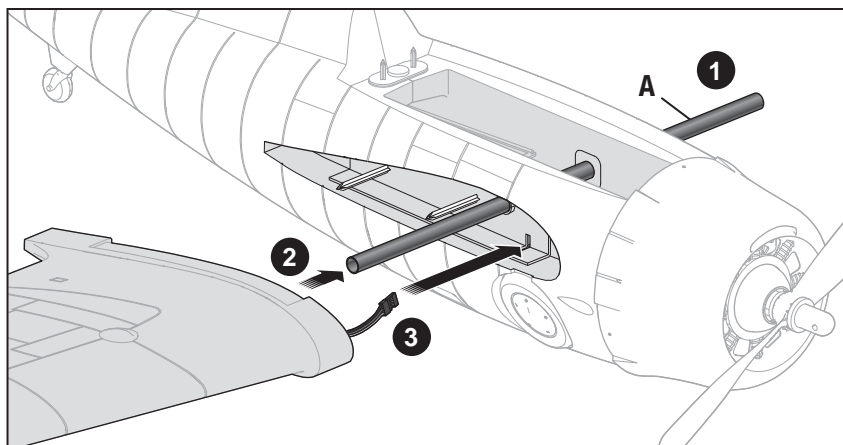

## Installing the Tail

1. Insert the horizontal stabilizer tube (A) into the hole in the rear of the fuselage.
2. Slide the right horizontal tail onto the tube on the right side of the fuselage until it seats into the slot in the fuselage.
3. Repeat Steps 1 and 2 for the left horizontal tail while connecting the elevator joiner to the left and right horizontal tails.
4. Attach the horizontal tail sections to the top and bottom of the fuselage with (4) pieces of tape (B).

**NOTICE:** Removing tape will remove paint from painted parts

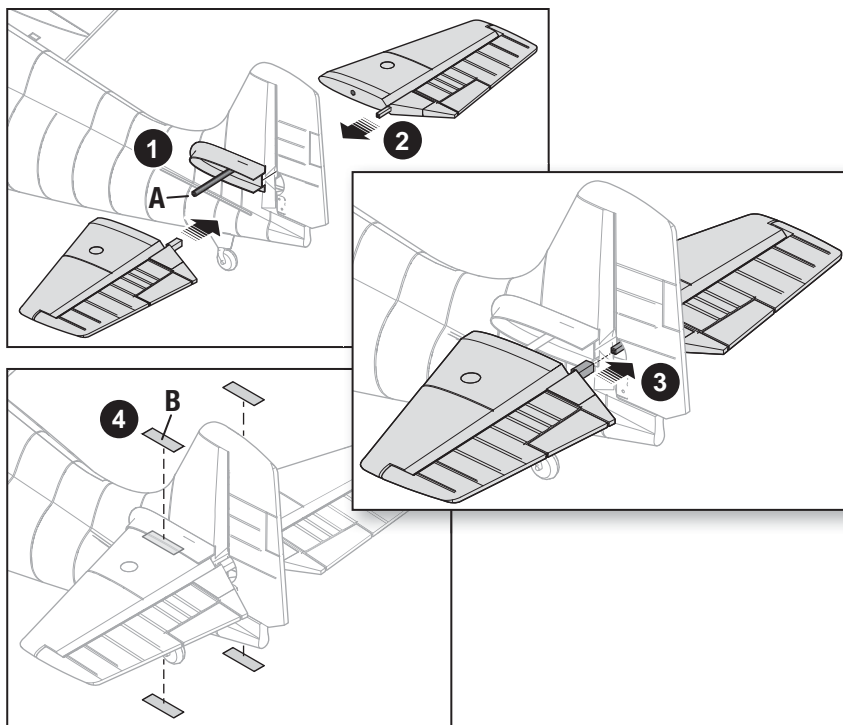

## Attaching the Clevis to the Control Horn

Finish the installation of the tail by connecting the control rod with the clevis on the tail control horn under the elevator.

1. Open the clevis and put the pin in **the bottom hole (A)** of the control horn.
2. If needed, remove the clevis from the control horn.
  - Turn the clevis (as shown) on the control rod (also called a pushrod).
  - Close the clevis onto the control horn and slide the tube towards the horn to secure the clevis.

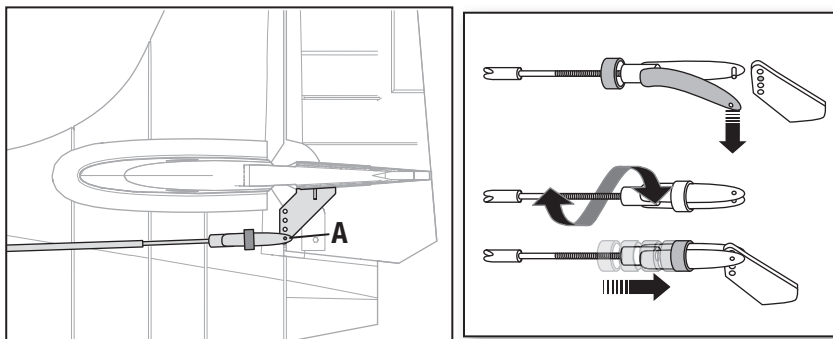

## Control Horn and Servo Arm Settings

The illustration shows recommended hole settings in the servo arms and control horns.

	Elevator	Ailerons	Rudder
Arms			
Horns			



## Receiver and Battery Selection and Installation

### Receiver Selection

The Spektrum AR636 receiver is recommended for this airplane. If you choose to install another receiver, ensure that it is at least a 6-channel full range (sport) receiver. Refer to your receiver manual for correct installation and operation instructions.

### Receiver Installation

1. Remove the canopy.
2. Install your full range (sport) receiver in the fuselage using double-sided servo tape.
3. Attach the elevator and rudder servo connectors to the appropriate channels of the receiver.
4. Attach the aileron Y-harness to the aileron channel of the receiver.
5. Attach the ESC connector to the throttle channel of the receiver.

**CAUTION:** Always disconnect the Li-Po flight battery from the aircraft receiver when not flying to avoid over-discharging the battery. Batteries discharged to a voltage lower than the lowest approved voltage may become damaged, resulting in loss of performance and potential fire when batteries are charged.

**CAUTION:** Always keep hands away from the propeller. When armed, the motor will turn the propeller in response to any throttle movement.

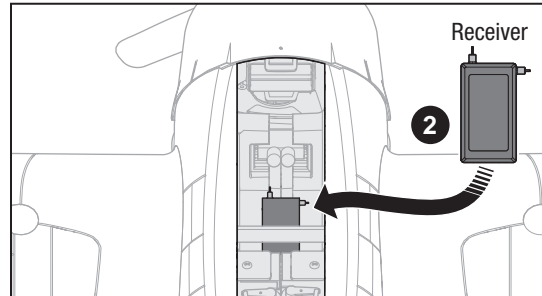
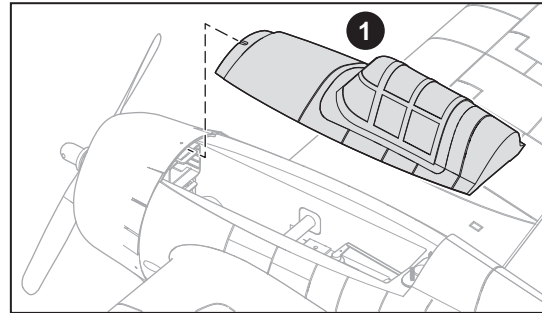

### Battery Selection

- We recommend the E-flite® 1300mAh 11.1V 3S 20C Li-Po (EFLB13003S20).
- If using another battery, the battery must be at least a 1300mAh battery.
- Your battery should be approximately the same capacity, dimensions and weight as the E-flite Li-Po battery to fit in the fuselage without changing the center of gravity a large amount.

### Battery Installation

1. Lower the throttle and throttle trim to the lowest settings. Power on the Transmitter, then wait 5 seconds.
2. Install the battery all the way to the front of the battery compartment. See the Center of Gravity instructions for more information.
3. Make sure the flight battery is secured using the hook and loop strap (A).
4. Connect the battery to the ESC and keep the aircraft immobile, level away from wind for 5 seconds.
  - The ESC will sound a series of tones (refer to step 5 of the binding instructions for more information).
  - An LED will light on the receiver (the red, blue and green gain LEDs will also flash).

If the ESC sounds a continuous double beep after the flight battery is connected, recharge or replace the battery.

5. Reinstall the canopy .

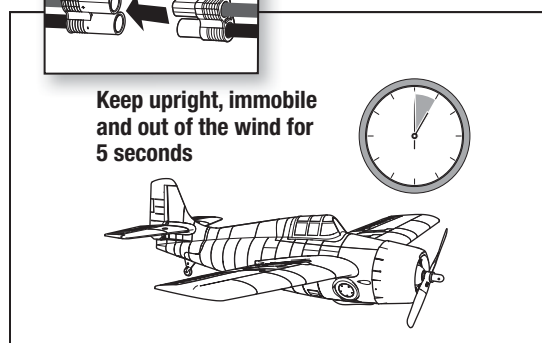
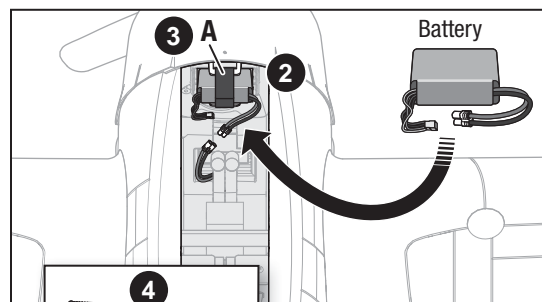
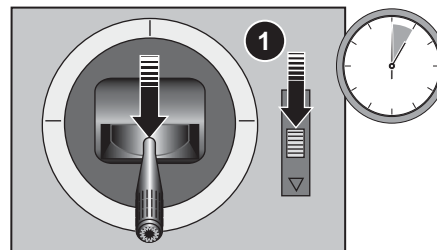

## Transmitter and Receiver Binding / Switching ON and OFF SAFE® Select

This product requires an approved Spektrum™ DSM2®/DSMX® compatible transmitter. Visit [www.bindnfly.com](http://www.bindnfly.com) for a complete list of approved transmitters.

The aircraft has an optional SAFE Select feature, which can be switched ON or OFF easily by binding in a specific manner as described below.

**IMPORTANT:** Before binding a transmitter, read the Transmitter Setup section of this manual to ensure that your transmitter is properly programmed for this aircraft.

### Bind Plug Installation

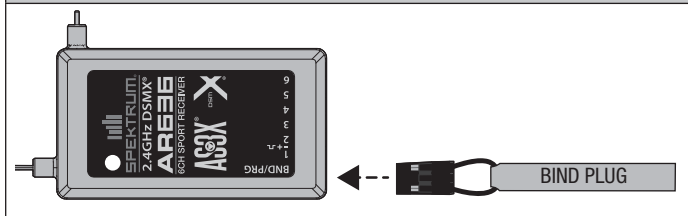

### Switching ON SAFE Select Binding Sequence

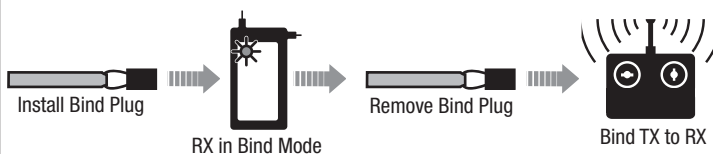

### Switching OFF SAFE Select Binding Sequence

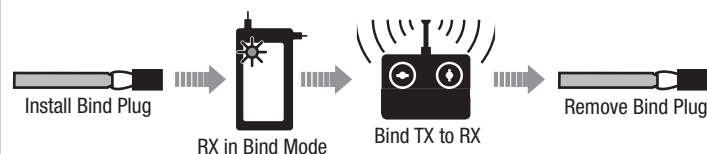

### Binding Procedure / Switching ON SAFE Select

**IMPORTANT:** The included AR636A receiver has been programmed for operation specifically for this aircraft. Refer to the receiver manual for correct setup if the receiver is replaced or is used in another aircraft.

**CAUTION:** When using a Futaba® transmitter with a Spektrum DSM module, you must reverse the throttle channel and rebind. Refer to your Spektrum module manual for binding and failsafe instructions. Refer to your Futaba transmitter manual for instructions on reversing the throttle channel.

1. Make sure the transmitter is powered off.
2. Move the transmitter controls to neutral (flight controls: rudder, elevators and ailerons) or to low positions (throttle, throttle trim).\*
3. Install a bind plug in the receiver bind port.
4. Place the aircraft on a level surface, connect the flight battery to the ESC, then turn ON the switch. The ESC will produce a series of sounds. 3 flat tones followed immediately by 2 ascending tones confirm that the LVC is set correctly for the ESC. The orange bind LED on the receiver will begin to flash rapidly.
5. Remove the bind plug from the bind port.
6. Take 3 steps away from the aircraft /receiver and then power ON the transmitter while holding the transmitter bind button or switch. Refer to your transmitter's manual for specific binding instructions.  
**IMPORTANT:** Do not point the transmitter's antenna directly at the receiver while binding.  
**IMPORTANT:** Keep away from large metal objects while binding.
7. The receiver is bound to the transmitter when the orange bind light on the receiver stays orange. The ESC will produce a series of sounds. 3 flat tones followed immediately by 2 ascending tones. The tones indicate the ESC is armed, provided the throttle stick and throttle trim are low enough to trigger arming.

**IMPORTANT:** Do not point the transmitter's antenna directly at the receiver while binding.

**IMPORTANT:** Keep away from large metal objects while binding.

**IMPORTANT:** Once bound, the receiver will retain its bind and last setting until it has been intentionally changed, even when power is cycled ON and OFF. However, if you notice that bind has been lost, simply repeat the binding process.

#### SAFE Select ON Indication

Every time the receiver is powered ON the surfaces will cycle back and forth twice with a slight pause at neutral position to indicate that SAFE Select is switched ON.

The throttle will not arm if the transmitter's throttle control is not put at the lowest position. If you encounter problems, follow the binding instructions and refer to the transmitter troubleshooting guide for other instructions. If needed, contact the appropriate Horizon Product Support office.

### Binding Procedure / Switching OFF SAFE Select

**IMPORTANT:** The included AR636A receiver has been programmed for operation specifically for this aircraft. Refer to the receiver manual for correct setup if the receiver is replaced or is used in another aircraft.

**CAUTION:** When using a Futaba® transmitter with a Spektrum DSM module, you must reverse the throttle channel and rebind. Refer to your Spektrum module manual for binding and failsafe instructions. Refer to your Futaba transmitter manual for instructions on reversing the throttle channel.

1. Make sure the transmitter is powered off.
2. Move the transmitter controls to neutral (flight controls: rudder, elevators and ailerons) or to low positions (throttle, throttle trim).\*
3. Install a bind plug in the receiver bind port.
4. Place the aircraft on a level surface, connect the flight battery to the ESC, then turn ON the switch. The ESC will produce a series of sounds. 3 flat tones followed immediately by 2 ascending tones confirm that the LVC is set correctly for the ESC.  
  
The orange bind LED on the receiver will begin to flash rapidly. DO NOT remove the bind plug at this time.
5. Take 3 steps away from the aircraft /receiver and then power ON the transmitter while holding the transmitter bind button or switch. Refer to your transmitter's manual for specific binding instructions.  
**IMPORTANT:** Do not point the transmitter's antenna directly at the receiver while binding.  
**IMPORTANT:** Keep away from large metal objects while binding.
6. The receiver is bound to the transmitter when the orange bind light on the receiver stays orange. The ESC will produce a series of sounds. 3 flat tones followed immediately by 2 ascending tones. The tones indicate the ESC is armed, provided the throttle stick and throttle trim are low enough to trigger arming.
7. Remove the bind plug from the bind port.

**IMPORTANT:** Once bound, the receiver will retain its bind and last setting until it has been intentionally changed, even when power is cycled ON and OFF. However, if you notice that bind has been lost, simply repeat the binding process.

#### SAFE Select OFF Indication

Every time the receiver is powered ON the surfaces will cycle back and forth once to indicate that SAFE Select has been switched OFF.

The throttle will not arm if the transmitter's throttle control is not put at the lowest position. If you encounter problems, follow the binding instructions and refer to the transmitter troubleshooting guide for other instructions. If needed, contact the appropriate Horizon Product Support office.

**\*Failsafe:** If the receiver loses transmitter communication, the failsafe will activate. When activated, failsafe moves the throttle channel to its preset failsafe position (low throttle) that was set during binding. All other channels move to actively level the aircraft in flight.

## SAFE® Select Switch Designation

SAFE® Select technology can be easily assigned to any open switch (2 or 3 position) on your transmitter. With this new feature, you have the flexibility to enable or disable the technology while in flight.

**IMPORTANT:** Before assigning your desired switch, ensure that the travel for that channel is set at 100% in both directions.

### Assigning a switch

1. Bind the aircraft correctly to activate SAFE Select. This will allow the system to be assigned to a switch.
2. Hold both transmitter sticks to the inside bottom corners and toggle the desired switch 5 times (1 toggle = full up and down) to assign that switch. The control surfaces of the aircraft will move, indicating the switch has been selected.

Repeat the process to assign a different switch if desired.

**NOTICE:** SAFE Select is assignable on any unused Channels 5–9.

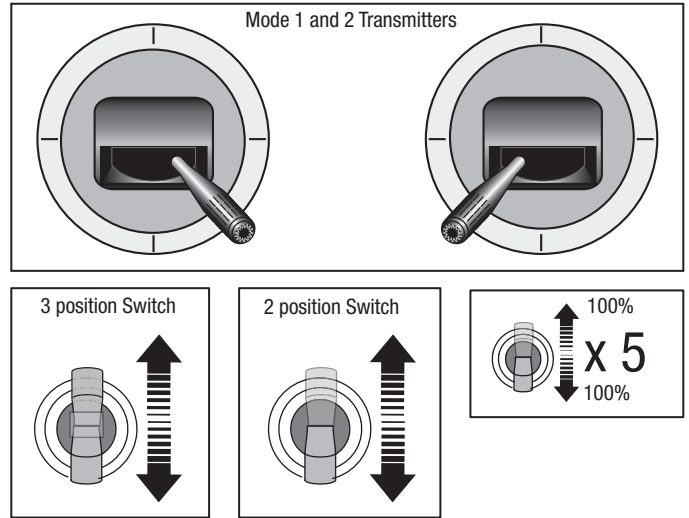

## Hi/Low Rate Switch (Dual Rates)

All DSM2/DSMX full range transmitters features dual rates to allow you to select the amount of travel that you want from the control surfaces.

Dual Rate	High Rate	Low Rate
<b>Aileron</b>	100%	70%
<b>Elevator</b>	100%	70%
<b>Rudder</b>	100%	70%

## Control Direction Test

Restrain the aircraft so it does not escape your control while you are testing your transmitter controls.

Move the sticks on the transmitter to ensure the aircraft responds as shown.

If your model does not respond as shown, DO NOT FLY! Refer to the Troubleshooting Guide in this manual for more information. If you need more assistance, contact the appropriate Horizon Hobby Product Support department.

	Transmitter Command	Aircraft Reaction
<b>Elevator</b>		
<b>Aileron</b>		
<b>Rudder</b>		



## Center of Gravity (CG)

An aircraft with correct CG has its weight balanced on the center of the aircraft for safe, stable flight.

Balance the aircraft on your fingertips near the fuselage under the wings. Adjust the battery position as needed.

- If the nose goes down, move the flight battery back until the aircraft balances.
- If the nose goes up, move the flight battery forward until the aircraft balances.

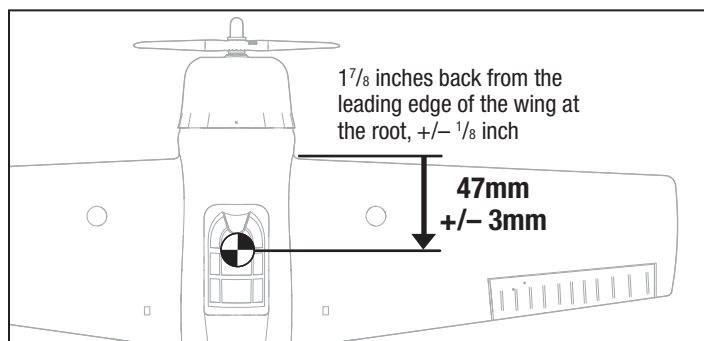

## Flying Tips and Repairs

**IMPORTANT:** Even though SAFE technology is a very helpful tool, the aircraft still needs to be flown manually. If incorrect input is given at lower altitudes or at slower speeds, the aircraft can crash.

### Choose a Flying Field

In order to have the most success and to protect your property and aircraft, it is very important to select a place to fly that is very open. Consult local laws and ordinances before choosing a location to fly your aircraft.

#### The site should:

- Have a minimum of approximately 1300 feet (400m) of clear space in all directions.
- Stay clear of pedestrians.
- Stay free of trees, buildings, cars, power lines or anything that could entangle your aircraft or interfere with your line of sight.

Remember, your aircraft can reach significant speeds when flying and can cover ground quickly. Plan on flying in an area that gives you more space than you think you need, especially with first flights

### Range Check your Radio System

Before you fly, range check the radio system. Refer to your specific transmitter instruction manual for range test information.

### Oscillation

Once the AS3X system is active (after advancing the throttle for the first time), you will normally see the control surfaces react to aircraft movement. In some flight conditions you may see oscillation (the aircraft rocks back and forth on one axis due to overcontrol). If oscillation occurs, refer to the Troubleshooting Guide for more information.

### Hand Launching

When hand-launching your aircraft alone, hold the aircraft in one hand and the transmitter in the other.

Apply about 1/2–3/4 throttle. Hold the aircraft on the underside and throw the aircraft directly into the wind, angled slightly up (5 to 10 degrees above the horizon). Climb to a safe altitude and check the trim. Once the trim is adjusted, begin exploring the flight envelope of the aircraft.

### Landing

If landing on grass, use the same approach as if flying an aircraft with landing gear. Start your flare with the power off about 1 foot above the ground and hold the nose off until the tail touches down. Try to keep the wings level to prevent grabbing a wing and turning the aircraft sideways.

**NOTICE:** If a crash is imminent, reduce the throttle fully. Failure to do so could result in extra damage to the airframe, as well as damage to the ESC and motor.

**NOTICE:** When you are finished flying, never leave the aircraft in direct sunlight or in a hot, enclosed area such as a car. Doing so can damage the aircraft.

**NOTICE:** Crash damage is not covered under warranty.

**CAUTION:** Never catch a flying aircraft in your hands. Doing so could cause personal injury and damage to the aircraft.

#### NOTICE

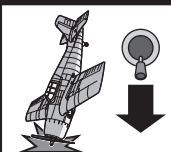

**Always decrease throttle at propeller strike.**







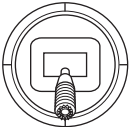

### Repairs

Repair this aircraft using CA (cyanoacrylate adhesive) glue or clear tape.

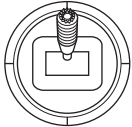
When parts are not repairable, see the Replacement Parts List for ordering by item number.

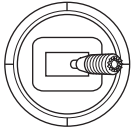
For a listing of all replacement and optional parts, refer to the list at the back of this manual.

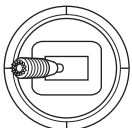
## Flying

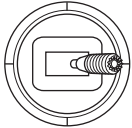
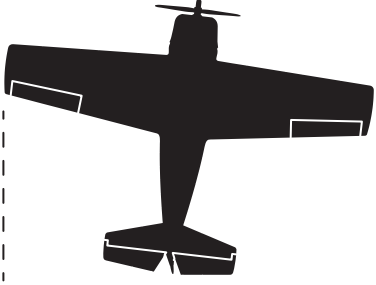
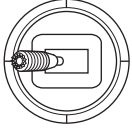
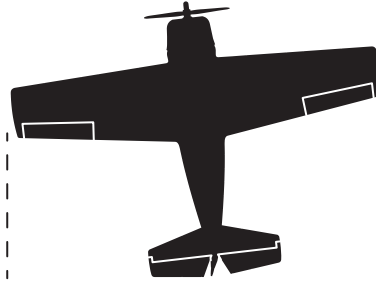
	Transmitter command	Aircraft Reaction
Elevator	Up Elevator Command 	
	Down Elevator Command 	
Aileron	Stick Right 	
	Stick Left 	
Rudder	Stick Right 	
	Stick Left 	

### Low Voltage Cutoff (LVC)

LVC is a mechanism built into your ESC to protect the battery from over-discharge. When the battery charge is too low, LVC limits power supplied to the motor. The aircraft will begin to slow and you will hear the motor pulse. When the motor power decreases, land the aircraft immediately and recharge the flight battery.

Disconnect and remove the Li-Po battery from the aircraft after use to prevent trickle discharge. Charge your Li-Po battery to about half capacity before storage. During storage, make sure the battery charge does not fall below 3V per cell.

### Prolong the life of your Battery

- Before storage, charge your battery to about half capacity. Capacity decreases with use and age.
- During storage, ensure the charge does not fall below 3V per cell.

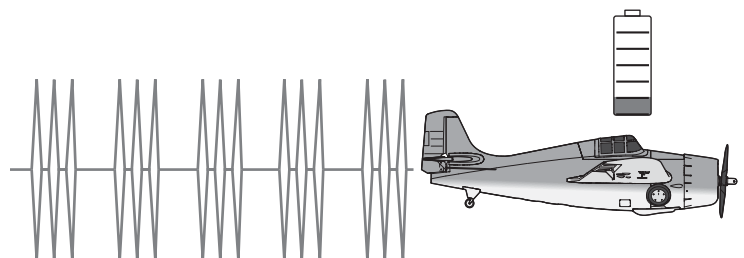

**NOTICE:** Repeated flying to LVC will damage the battery.

## Post Flight

**NOTICE:** When you are finished flying, never leave the aircraft in direct sunlight or in a hot, enclosed area such as a car. Doing so can damage the foam.

### Post Flight Checklist

1. Disconnect flight battery from the aircraft. (Required for Safety)	
2. Remove flight battery from the aircraft.	
3. Power off transmitter.	
4. Recharge flight battery.	
5. Repair or replace all damaged parts.	
6. Store flight battery apart from the aircraft and monitor the battery charge.	
7. Make note of flight conditions and flight plan results, planning for future flights.	

## Trimming the Aircraft

### Adjusting Trim in Flight

If your aircraft does not fly straight and level at half throttle with the steering stick at center, fly into the wind and move the trim sliders.

	Aircraft drift	Required Trim
Elevators		
Ailerons		
Rudders		

### Manually Adjusting Trim

Perform manual adjustment of trim before increasing the throttle above 25% or the control surfaces will move when the aircraft is moved.

Return any trim setting on the transmitter to neutral by pushing the trim slider to the middle position, then adjusting the clevis on that control surface to position it the same as it was with the trim slider offset.

1. Remove the clevis from the control horn.
2. Turn the clevis (as shown) to lengthen or shorten the pushrod.
3. Close the clevis onto the control horn and slide the tube towards the horn to secure the clevis.

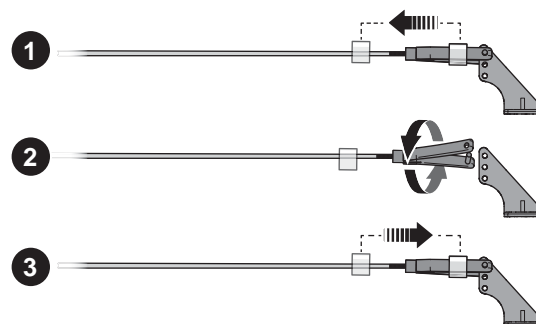

## Service of Power Components

**CAUTION:** Always disconnect the flight battery from the model before removing the propeller.

### Disassembly

1. Loosen the spinner nut (**A**) on the collet shaft and remove.
2. Remove the propeller (**B**) from the collet shaft.
3. Remove the collet (**D**) from the motor shaft.
4. Remove the (4) screws (**C**) from the cowl.
5. Remove (4) screws (**E**) from the motor mount (**F**) and the fuselage.
6. Assemble in reverse order.

### Assembly Tips

- Correctly align and connect the motor wire colors with the ESC wires.
- Ensure that all screws are tight and secure.

### Service and Repair

**NOTICE:** If you replace the receiver, install the new receiver in the same orientation and manner as the original receiver or damage may result.

Thanks to the EPO material, repairs to the foam can be made using regular CA (cyanoacrylate adhesive).

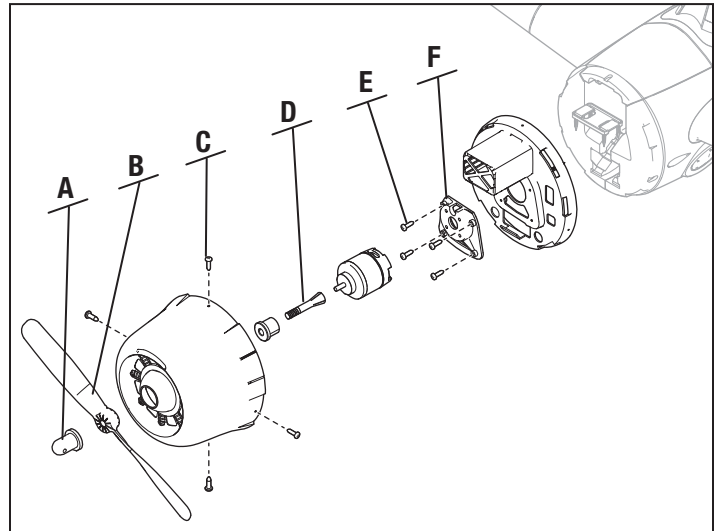

## Troubleshooting Guide

Problem	Possible Cause	Solution
Aircraft oscillates	Loose or damaged propeller, shaft or motor	Replace parts or correctly align all parts and tighten fasteners as needed
	Loose receiver	Align and secure receiver in fuselage
	Loose aircraft controls	Tighten or otherwise secure parts (servo, arm, linkage, horn and control surface)
	Worn parts	Replace worn parts (especially propeller, spinner or servo)
Trim is at extreme and aircraft does not fly straight or level	Trim is not at neutral	If you need to adjust trim more than 8 clicks, return the trim to neutral and manually adjust the clevis to mechanically remove trim
Trim change when flight mode is switched	Receiver did not save trim setting	After adjusting transmitter trim in the air or on the ground, do not touch the control sticks for 2 seconds
Aircraft will not respond to throttle but responds to other controls	Throttle not at lowest position or throttle trim too high	Reset controls with throttle stick and throttle trim at lowest setting
	Throttle channel is reversed	Reverse throttle channel on transmitter
	Motor disconnected from Receiver/ESC	Make sure motor is connected to the Receiver/ESC
Extra propeller noise or extra vibration	Damaged propeller, shaft or motor	Replace damaged parts
	Propeller is out of balance	Balance or replace propeller
Reduced flight time or aircraft underpowered	Flight battery charge is low	Completely recharge flight battery
	Flight battery damaged	Replace flight battery and follow flight battery instructions
	Flight conditions may be too cold	Make sure battery is warm before use
Aircraft will not Bind (during binding) to transmitter. Refer to the transmitter manual for binding instructions	Transmitter too near aircraft during binding process	Move powered transmitter a few feet from aircraft, disconnect and reconnect flight battery to aircraft
	Aircraft or transmitter is too close to large metal object, wireless source or another transmitter	Move aircraft and transmitter to another location and attempt binding again
	Flight battery/transmitter battery charge is too low	Replace/recharge batteries
	The bind plug is not installed correctly in the bind port	Install bind plug in bind port and bind the aircraft to the transmitter
	Bind switch or button not held long enough during bind process	Power off transmitter and repeat bind process. Hold transmitter bind button or switch until receiver is bound
Aircraft will not connect (after binding) to transmitter. Refer to the transmitter manual for binding instructions	Transmitter too near aircraft during connecting process	Move powered transmitter a few feet from aircraft, disconnect and reconnect flight battery to aircraft
	Aircraft or transmitter is too close to large metal object, wireless source or another transmitter	Move aircraft and transmitter to another location and attempt connecting again
	Bind plug left installed in bind port	Rebind transmitter to the aircraft and remove the bind plug before cycling power
	Flight battery/Transmitter battery charge is too low	Replace/recharge batteries
	Transmitter may have been bound to a different aircraft using different DSM protocol	Bind aircraft to transmitter
Control surface does not move	Control surface, control horn, linkage or servo damage	Replace or repair damaged parts and adjust controls
	Wire damaged or connections loose	Do a check of wires and connections, connect or replace as needed
	Flight battery charge is low	Fully recharge flight battery
	Receiver is damaged	Replace Receiver
Controls reversed	Transmitter settings are reversed	Perform the Control Direction Test and adjust the controls on transmitter appropriately
Motor power pulses then motor loses power	Normal Low Voltage Cutoff (LVC)	Recharge flight battery or replace battery that is no longer performing
	Weather conditions might be too cold	Postpone flight until weather is warmer
	Battery is old, worn out, or damaged	Replace battery
	Battery C rating might be too small	Use recommended battery

## Limited Warranty

**What this Warranty Covers** – Horizon Hobby, LLC, (Horizon) warrants to the original purchaser that the product purchased (the “Product”) will be free from defects in materials and workmanship at the date of purchase.

**What is Not Covered** – This warranty is not transferable and does not cover (i) cosmetic damage, (ii) damage due to acts of God, accident, misuse, abuse, negligence, commercial use, or due to improper use, installation, operation or maintenance, (iii) modification of or to any part of the Product, (iv) attempted service by anyone other than a Horizon Hobby authorized service center, (v) Product not purchased from an authorized Horizon dealer, or (vi) Product not compliant with applicable technical regulations, or (vii) use that violates any applicable laws, rules, or regulations.

OTHER THAN THE EXPRESS WARRANTY ABOVE, HORIZON MAKES NO OTHER WARRANTY OR REPRESENTATION, AND HEREBY DISCLAIMS ANY AND ALL IMPLIED WARRANTIES, INCLUDING, WITHOUT LIMITATION, THE IMPLIED WARRANTIES OF NON-INFRINGEMENT, MERCHANTABILITY AND FITNESS FOR A PARTICULAR PURPOSE. THE PURCHASER ACKNOWLEDGES THAT THEY ALONE HAVE DETERMINED THAT THE PRODUCT WILL SUITABLY MEET THE REQUIREMENTS OF THE PURCHASER'S INTENDED USE.

**Purchaser's Remedy** – Horizon's sole obligation and purchaser's sole and exclusive remedy shall be that Horizon will, at its option, either (i) service, or (ii) replace, any Product determined by Horizon to be defective. Horizon reserves the right to inspect any and all Product(s) involved in a warranty claim. Service or replacement decisions are at the sole discretion of Horizon. Proof of purchase is required for all warranty claims. SERVICE OR REPLACEMENT AS PROVIDED UNDER THIS WARRANTY IS THE PURCHASER'S SOLE AND EXCLUSIVE REMEDY.

**Limitation of Liability** – HORIZON SHALL NOT BE LIABLE FOR SPECIAL, INDIRECT, INCIDENTAL OR CONSEQUENTIAL DAMAGES, LOSS OF PROFITS OR PRODUCTION OR COMMERCIAL LOSS IN ANY WAY, REGARDLESS OF WHETHER SUCH CLAIM IS BASED IN CONTRACT, WARRANTY, TORT, NEGLIGENCE, STRICT LIABILITY OR ANY OTHER THEORY OF LIABILITY, EVEN IF HORIZON HAS BEEN ADVISED OF THE POSSIBILITY OF SUCH DAMAGES. Further, in no event shall the liability of Horizon exceed the individual price of the Product on which liability is asserted. As Horizon has no control over use, setup, final assembly, modification or misuse, no liability shall be assumed nor accepted for any resulting damage or injury. By the act of use, setup or assembly, the user accepts all resulting liability. If you as the purchaser or user are not prepared to accept the liability associated with the use of the Product, purchaser is advised to return the Product immediately in new and unused condition to the place of purchase.

**Law** – These terms are governed by Illinois law (without regard to conflict of law principals). This warranty gives you specific legal rights, and you may also have other rights which vary from state to state. Horizon reserves the right to change or modify this warranty at any time without notice.

### WARRANTY SERVICES

**Questions, Assistance, and Services** – Your local hobby store and/or place of purchase cannot provide warranty support or service. Once assembly, setup or use of the Product has been started, you must contact your local distributor or Horizon directly. This will enable Horizon to better answer your questions and service you in the event that you may need any assistance. For questions or assistance, please visit

our website at [www.horizonhobby.com](http://www.horizonhobby.com), submit a Product Support Inquiry, or call the toll free telephone number referenced in the Warranty and Service Contact Information section to speak with a Product Support representative.

**Inspection or Services** – If this Product needs to be inspected or serviced and is compliant in the country you live and use the Product in, please use the Horizon Online Service Request submission process found on our website or call Horizon to obtain a Return Merchandise Authorization (RMA) number. Pack the Product securely using a shipping carton. Please note that original boxes may be included, but are not designed to withstand the rigors of shipping without additional protection. Ship via a carrier that provides tracking and insurance for lost or damaged parcels, as Horizon is not responsible for merchandise until it arrives and is accepted at our facility. An Online Service Request is available at [http://www.horizonhobby.com/content/\\_service-center\\_render-service-center](http://www.horizonhobby.com/content/_service-center_render-service-center). If you do not have internet access, please contact Horizon Product Support to obtain a RMA number along with instructions for submitting your product for service. When calling Horizon, you will be asked to provide your complete name, street address, email address and phone number where you can be reached during business hours. When sending product into Horizon, please include your RMA number, a list of the included items, and a brief summary of the problem. A copy of your original sales receipt must be included for warranty consideration. Be sure your name, address, and RMA number are clearly written on the outside of the shipping carton.

**NOTICE:** Do not ship LiPo batteries to Horizon. If you have any issue with a LiPo battery, please contact the appropriate Horizon Product Support office.

**Warranty Requirements** – For Warranty consideration, you must include your original sales receipt verifying the proof-of-purchase date. Provided warranty conditions have been met, your Product will be serviced or replaced free of charge. Service or replacement decisions are at the sole discretion of Horizon.

**Non-Warranty Service** – Should your service not be covered by warranty, service will be completed and payment will be required without notification or estimate of the expense unless the expense exceeds 50% of the retail purchase cost. By submitting the item for service you are agreeing to payment of the service without notification. Service estimates are available upon request. You must include this request with your item submitted for service. Non-warranty service estimates will be billed a minimum of ½ hour of labor. In addition you will be billed for return freight. Horizon accepts money orders and cashier's checks, as well as Visa, MasterCard, American Express, and Discover cards. By submitting any item to Horizon for service, you are agreeing to Horizon's Terms and Conditions found on our website [http://www.horizonhobby.com/content/service-center\\_render-service-center](http://www.horizonhobby.com/content/service-center_render-service-center).

**ATTENTION:** Horizon service is limited to Product compliant in the country of use and ownership. If received, a non-compliant Product will not be serviced. Further, the sender will be responsible for arranging return shipment of the un-serviced Product, through a carrier of the sender's choice and at the sender's expense. Horizon will hold non-compliant Product for a period of 60 days from notification, after which it will be discarded.

10/2015

## Warranty and Service Contact Information

Country of Purchase	Horizon Hobby	Phone Number/Email Address	Address
United States of America	Horizon Service Center (Repairs and Repair Requests)	<a href="http://servicecenter.horizonhobby.com/Request-Form/">servicecenter.horizonhobby.com/Request-Form/</a>	4105 Fieldstone Rd Champaign, Illinois, 61822 USA
	Horizon Product Support (Product Technical Assistance)	<a href="mailto:productsupport@horizonhobby.com">productsupport@horizonhobby.com</a> 877-504-0233	
	Sales	<a href="mailto:sales@horizonhobby.com">sales@horizonhobby.com</a> 888-959-2305	
European Union	Horizon Technischer Service Sales: Horizon Hobby GmbH	<a href="mailto:service@horizonhobby.eu">service@horizonhobby.eu</a> +49 (0) 4121 2655 100	Hanskampring 9 D 22885 Barsbüttel, Germany

## FCC Information

### FCC ID: BRWDASRX15

PKZ1950: This equipment has been tested and found to comply with the limits for a Class B digital device, pursuant to part 15 of the FCC Rules. These limits are designed to provide reasonable protection against harmful interference in a residential installation. This equipment generates, uses and can radiate radio frequency energy and, if not installed and used in accordance with the instructions, may cause harmful interference to radio communications.

However, there is no guarantee that interference will not occur in a particular installation. If this equipment does cause harmful interference to radio or television reception, which can be determined by turning the equipment off and on, the user is encouraged to try to correct the interference by one or more of the following measures:

- Reorient or relocate the receiving antenna.
- Increase the separation between the equipment and receiver.
- Connect the equipment to an outlet on a circuit different from that to which the receiver is connected.

This device complies with part 15 of the FCC rules. Operation is subject to the following two conditions: (1) This device may not cause harmful interference, and (2) this device must accept any interference received, including interference that may cause undesired operation.

**NOTICE:** Modifications to this product will void the user's authority to operate this equipment.

This product contains a radio transmitter with wireless technology which has been tested and found to be compliant with the applicable regulations governing a radio transmitter in the 2.400GHz to 2.4835GHz frequency range.

### Antenna Separation Distance

When operating your transmitter, please be sure to maintain a separation distance of at least 20 cm between your body (excluding fingers, hands, wrists, ankles and feet) and the antenna to meet RF exposure safety requirements as determined by FCC regulations.

This illustration shows the approximate 20 cm RF exposure area and typical hand placement when operating your transmitter.

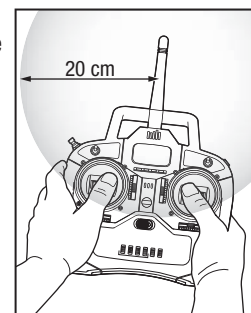

## IC Information

### IC ID: 6157A-AMRX15

PKZ1950: This device complies with Industry Canada licence-exempt RSS standard(s). Operation is subject to the following two conditions: (1) this device may not cause interference, and (2) this device must accept any interference, including interference that may cause undesired operation of the device.

## Compliance Information for the European Union

### CE EU Compliance Statement:

PKZ1950: Horizon Hobby, LLC hereby declares that this product is in compliance with the essential requirements and other relevant provisions of the RED and EMC Directives.

PKZ1975: Horizon Hobby, LLC hereby declares that this product is in compliance with the essential requirements and other relevant provisions of the EMC Directive.

A copy of the EU Declaration of Conformity is available online at: <http://www.horizonhobby.com/content/support-render-compliance>.

### Instructions for disposal of WEEE by users in the European Union



This product must not be disposed of with other waste. Instead, it is the user's responsibility to dispose of their waste equipment by handing it over to a designated collections point for the recycling of waste electrical and electronic equipment. The separate collection and recycling of your waste equipment at the time of disposal will help to conserve natural resources and make sure that it is recycled in a manner that protects human health and the environment. For more information about where you can drop off your waste equipment for recycling, please contact your local city office, your household waste disposal service or where you purchased the product.



E328

## Replacement Parts • Ersatzteile • Pièces de rechange • Pezzi di ricambio

Part #   Nummer Numéro   Codice	Description	Beschreibung	Description	Descrizione
PKZ1908	Landing gear set	Fahrwerksatz	Ensemble de train d'atterrissage	Set carrello d'atterraggio
PKZ1913	Complete Canopy w/Pilot	Vollständige Kanzelabdeckung m. Pilot	Verrière complète avec pilote	Tettuccio completo con pilota
PKZ1902	Decal Sheet: F4F	Abziehbild	Feuille de décalomanie	Foglio di decalcomanie
PKZ4416	Motor: 480 Brushless Outrunner 960Kv	Motor: 480 Bürstenloser Outrunner 960Kv	Moteur: 480 Outrunner sans balai 960Kv	Motore: 480 outrunner brushless 960Kv
PKZ1918	Prop Adapter and Hub	Propeller-Adapter und Nabe	Adaptateur d'hélice et moyeu	Adattatore elica e mozzo
PKZ1081	SV80 Long Lead Servo	SV80 lange Führungsservo	Servomoteur de plomb long SV80	SV80 servo lungo guida
PKZ1080	SV80 Short Lead Servo	SV80 Kurzleitung Servo	Servomoteur de plomb court SV80	SV80 servo corto
PKZ1920	Painted Wing	Lackierter Flügel	Aile peinte	Ala verniciata
PKZ1922	Pushrod Set	Schubstangensatz	Ensemble de poussoirs	Set di pushrod
PKZ1923	Control Horn Set	Steuerhornsatz	Ensemble de renvoi de commande	Set squadrette di controllo
PKZ1924	Horizontal Tail w/Access	Horizontalleitwerk mit Zugang	Empennage horizontal avec accès	Piano di coda orizzontale con accesso
PKZ1926	Painted Cowl	Lackierte Motorhaube	Capot peint	Cappottatura verniciata
PKZ1814	18-Amp BEC Brushless ESC (V2)	18-Amp Akku-Sperrkreis (BEC) Bürstenloser Geschwindigkeitsregler (V2)	Variateur ESC sans balais avec circuit BEC 18 A (V2)	18-Amp BEC Brushless ESC (V2)
PKZ1928	Motor Mount	Motorhalterung	Support moteur	Supporto motore
PKZ1935	Servo Wire Tape	Servokabel-Band	Ruban adhésif du câble du servo	Nastro cavi servocomandi
PKZ1967	Painted Bare Fuselage	Lackierter bloßer Rumpf	Fuselage nu peint	Fusoliera semplice verniciata
PKZ1970	Replacement Airframe	Ersatzflugzeugrahmen	Structure de vol de remplacement	Cellula sostitutiva
SPMAR636A	AR636A 6-Ch AS3X Sport Receiver	AR636A-6-Kanal-AS3X-Sportempfänger	Récepteur AR636A AS3X Sport 6 canaux	Ricevente Sport AR636A 6 canali AS3X

## Optional Parts • Optionale Bauteile • Pièces optionnelles • Pezzi opzionali

Part #   Nummer Numéro   Codice	Description	Beschreibung	Description	Descrizione
PKZ1029	11.1V 3S 25C 2200mAh LiPo	11,1V 3S 25C 2200mAh LiPo	Li-Po 11,1 V 2200 mAh, 3S, 25C	11,1 V 3S 25C 2200mAh Li-Po
PKZ1033	1300mAh 11.1v LiPo with EC3	1300mAh 11,1v LiPo mit EC3	Li-Po 1300 mAh, 11,1 V avec EC3	1300mAh 11,1 V Li-Po con EC3
EFLB13003S20	1300mAh 11.1v LiPo with EC3	1300mAh 11,1v LiPo mit EC3	Li-Po 1300 mAh, 11,1 V avec EC3	1300mAh 11,1 V Li-Po con EC3
EFLB22003S30	11.1V 3S1P 30C 2200mAh LiPo	11,1V 3S1P 30C 2200mAh LiPo	Li-Po 11,1 V 2200 mAh, 3S1P, 30C	11,1 V 3S1P 30C 2200mAh Li-Po
EFLA111	Li-Po Cell Voltage Checker	E-flite Li-Po Cell Volt Checker	Contrôleur de tension Li-Po	Controllo tensione batteria LiPo
DYNC2010CA	Prophet Sport Plus 50W AC/DC Battery Charger	Prophet Sport Plus 50W AC / DC Ladegerät	Prophet Sport Plus 50W Chargeur de batterie AC / DC	Prophet Sport Plus 50W Caricabatterie AC / DC
	DX6i DSMX 6-Channel Transmitter	Spektrum DX6i DSMX 6-Kanal Sender	Émetteur DX6i DSMX 6 voies	DX6i DSMX Trasmettitore 6 canali
HBZ7390	Float Set	Schwimmsets	Ensemble de flotteur	Set di galleggianti
EFLA250	Park Flyer Tool Assortment	Park Flyer Werkzeug Sortiment	Park Flyer assortiment d'outils	Park Flyer assortimento degli utensili
EFLAEC303	EC3 Device and Battery Connector	EC3 Gerät und Batterieanschluss	Dispositif EC3 et connecteur de batterie	EC3 dispositivo e connettore batteria
SPMA3081	Transmitter/Receiver Programming Cable: Audio Interface	Sender / Empfänger Programmierkabel: Audio-Schnittstelle	Câble de programmation émetteur / récepteur: interface audio	Cavo di programmazione trasmettitore / ricevente: interfaccia audio
EFLAEC302	EC3 Battery Connector	EC3 Batterie Anschluss	Batterie EC3 Connecteur	Connettore della batteria
DYNC2005CA	Prophet Sport LiPo 35W AC/DC Battery Charger	Prophet Sport Plus LiPo 35W AC / DC Ladegerät	Prophet Sport Plus LiPo 35W Chargeur de batterie AC / DC	Prophet Sport LiPo 35W Caricabatterie AC / DC
SPMA3065	Transmitter/Receiver Programming Cable: USB Interface	Sender / Empfänger Programmierkabel: USB-Schnittstelle	Câble de programmation émetteur / récepteur: interface USB	Cavo di programmazione trasmettitore / ricevente: interfaccia USB
DYN1400	Small LiPo Charge Protection Bag	Kleine LiPo Ladeschutzbeutel	Petit sac de protection de charge LiPo	Borsa piccola protezione LiPo
RVO1005	Deluxe Ball Link Pliers	Deluxe Kugelgelenkzange	Pince à jarre de luxe	Pinze a sfera a sfere Deluxe
DYN1405	Large LiPo Charge Protection Bag	Große LiPo Ladeschutzbeutel	Grand sac de protection de charge LiPo	Borsa grande protezione LiPo
SPMAR636	AR636 6-Ch AS3X Sport Receiver	AR636-6-Kanal-AS3X-Sportempfänger	Récepteur AR636 AS3X Sport 6 canaux	Ricevente Sport AR636 6 canali AS3X



© 2017 Horizon Hobby, LLC.

ParkZone, E-flite, AS3X, SAFE, the SAFE logo, DSM, DSM2, DSMX, Bind-N-Fly, BNF, the BNF logo, EC3, Prophet, Plug-N-Play and ModelMatch are trademarks or registered trademarks of Horizon Hobby, LLC.

The Spektrum trademark is used with permission of Bachmann Industries, Inc.

All other trademarks, service marks and logos are property of their respective owners. US 9,056,667. US 8,672,726.

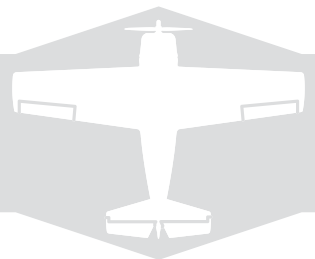

[www.parkzone.com](http://www.parkzone.com)  
PKZ1950, PKZ1975