

FIREBIRD

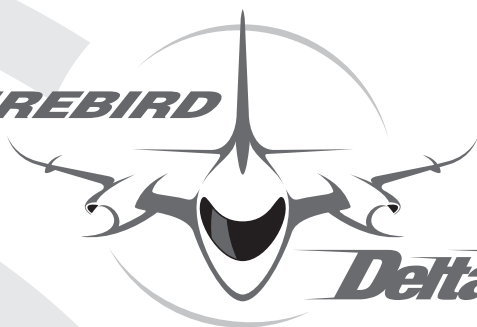

DeltaRay™

Instruction Manual • Bedienungsanleitung • Manuel d'utilisation • Manuale di Istruzioni

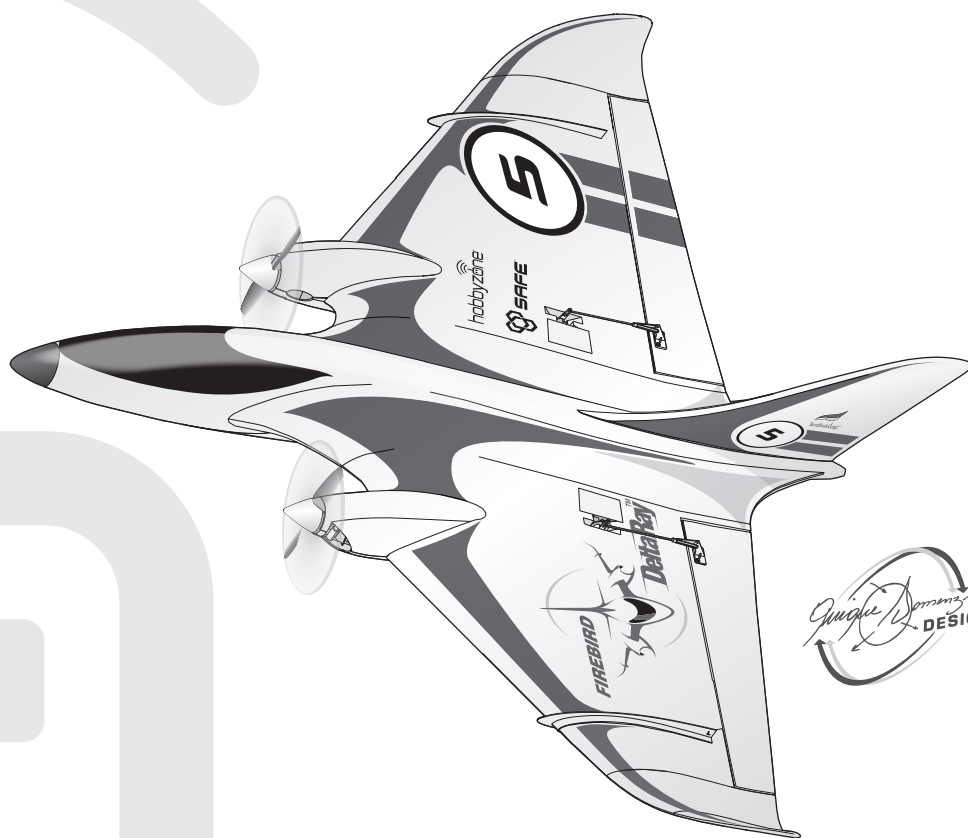

hobbyzone®

RTF
READY-TO-FLY

BNF
Bind-N-Fly.® Ready to fly. redefined.

SAFE™

NOTICE

All instructions, warranties and other collateral documents are subject to change at the sole discretion of Horizon Hobby, Inc. For up-to-date product literature, visit www.horizonhobby.com and click on the support tab for this product.

Meaning of Special Language:

The following terms are used throughout the product literature to indicate various levels of potential harm when operating this product:
NOTICE: Procedures, which if not properly followed, create a possibility of physical property damage AND little or no possibility of injury.

CAUTION: Procedures, which if not properly followed, create the probability of physical property damage AND a possibility of serious injury.

WARNING: Procedures, which if not properly followed, create the probability of property damage, collateral damage, and serious injury OR create a high probability of superficial injury.



WARNING: Read the ENTIRE instruction manual to become familiar with the features of the product before operating. Failure to operate the product correctly can result in damage to the product, personal property and cause serious injury.

This is a sophisticated hobby product. It must be operated with caution and common sense and requires some basic mechanical ability. Failure to operate this Product in a safe and responsible manner could result in injury or damage to the product or other property. This product is not intended for use by children without direct adult supervision. Do not use with incompatible components or alter this product in any way outside of the instructions provided by Horizon Hobby, Inc. This manual contains instructions for safety, operation and maintenance. It is essential to read and follow all the instructions and warnings in the manual, prior to assembly, setup or use, in order to operate correctly and avoid damage or serious injury.

Age Recommendation: Not for children under 14 years. This is not a toy.



WARNING AGAINST COUNTERFEIT PRODUCTS: If you ever need to replace your Spektrum receiver found in a Horizon Hobby product, always purchase from Horizon Hobby, Inc. or a Horizon Hobby authorized dealer to ensure authentic high-quality Spektrum product. Horizon Hobby, Inc. disclaims all support and warranty with regards, but not limited to, compatibility and performance of counterfeit products or products claiming compatibility with DSM or Spektrum.

Safety Precautions and Warnings

As the user of this product, you are solely responsible for operating in a manner that does not endanger yourself and others or result in damage to the product or the property of others.

- Always keep a safe distance in all directions around your model to avoid collisions or injury. This model is controlled by a radio signal subject to interference from many sources outside your control. Interference can cause momentary loss of control.
- Always operate your model in open spaces away from full-size vehicles, traffic and people.
- Always carefully follow the directions and warnings for this and any optional support equipment (chargers, rechargeable battery packs, etc.).
- Always keep all chemicals, small parts and anything electrical out of the reach of children.

- Always avoid water exposure to all equipment not specifically designed and protected for this purpose. Moisture causes damage to electronics.
- Never place any portion of the model in your mouth as it could cause serious injury or even death.
- Never operate your model with low transmitter batteries.
- Always keep aircraft in sight and under control.
- Always use fully charged batteries.
- Always keep transmitter powered on while aircraft is powered.
- Always remove batteries before disassembly.
- Always keep moving parts clean.
- Always keep parts dry.
- Always let parts cool after use before touching.
- Always remove batteries after use.
- Always ensure failsafe is properly set before flying.
- Never operate aircraft with damaged wiring.
- Never touch moving parts.

Charging Warnings



CAUTION: All instructions and warnings must be followed exactly. Mishandling of Li-Po batteries can result in a fire, personal injury, and/or property damage.

- By handling, charging or using the included Li-Po battery, you assume all risks associated with lithium batteries.
- If at any time the battery begins to balloon or swell, discontinue use immediately. If charging or discharging, discontinue and disconnect. Continuing to use, charge or discharge a battery that is ballooning or swelling can result in fire.
- Always store the battery at room temperature in a dry area for best results.
- Always transport or temporarily store the battery in a temperature range of 40–120° F (5–49° C). Do not store battery or aircraft in a car or direct sunlight. If stored in a hot car, the battery can be damaged or even catch fire.
- Always charge batteries away from flammable materials.

- Always inspect the battery before charging and never charge dead or damaged batteries.
- Always disconnect the battery after charging, and let the charger cool between charges.
- Always constantly monitor the temperature of the battery pack while charging.
- ONLY USE A CHARGER SPECIFICALLY DESIGNED TO CHARGE LI-PO BATTERIES. Failure to charge the battery with a compatible charger may cause fire resulting in personal injury and/or property damage.
- Never discharge Li-Po cells to below 3V under load.
- Never cover warning labels with hook and loop strips.
- Never leave charging batteries unattended.
- Never charge batteries outside recommended levels.
- Never attempt to dismantle or alter the charger.
- Never allow minors under the age of 14 to charge battery packs.
- Never charge batteries in extremely hot or cold places (recommended between 40–120° F or 5–49° C) or place in direct sunlight.

Included in the Box

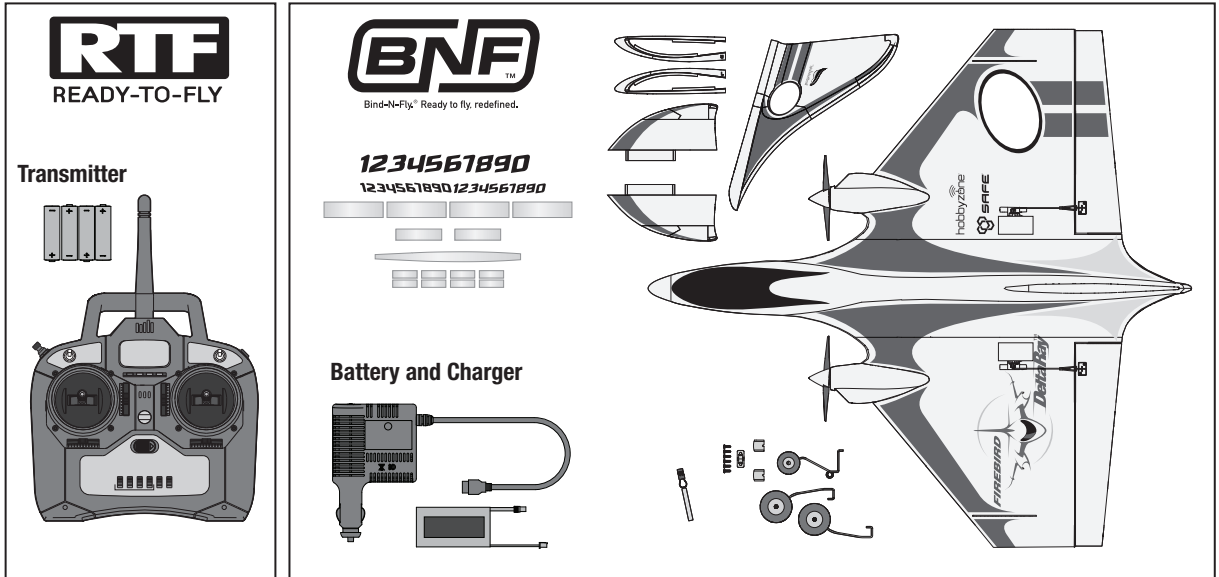

For more information and to register your product online, visit www.hobbyzonerc.com

Flying Tips

- Sensor Assisted Flight Envelope (SAFE™) technology is designed as flight assistance, not an autopilot. The pilot is always in control and required to fly the aircraft at all times.
- Start in Beginner mode (SAFE switch position 0). As you learn and become more confident, change modes to advance your flying skills.
- Always keep your aircraft in plain sight and upwind from you.
- Do not attempt your first turn at low altitude. Higher altitudes allow for greater possibility of correction.
- Always make deliberate and steady control stick movements for smooth control of your aircraft.
- Do not fly in winds greater than 8-10 mph. If flying in winds 5-10mph and in beginner Mode (SAFE position 0), you will likely need to fly in High Rates.

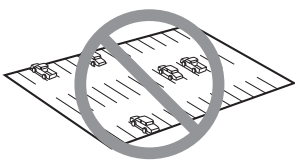
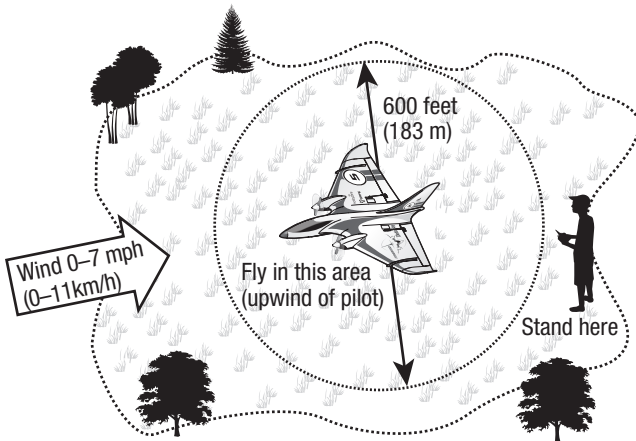

Preflight Checklist

- | | |
|---|---|
| 1. Find a safe and open area. | ✓ |
| 2. Charge flight battery. | |
| 3. Install flight battery in aircraft. | |
| 4. Perform Control Direction Test. | |
| 5. Plan flight for flying field conditions. | |
| 6. Have fun! | |

Charging the Flight Battery



CAUTION: When connecting the battery to the battery charger, make sure the connectors are aligned as shown. Failure to connect the battery properly could cause the terminals to short and result in fire, personal injury and/or property damage.

Charger Specifications

- Input power: 10–14V
- Max output voltage: 8.4V
- Fixed charge current: 1.5A
- Balances and charges 2S Li-Po cells with a minimum capacity of 1300mAh

This charger may be connected to a 1.5A AC Power Supply (sold separately). Refer to the Optional Parts List.

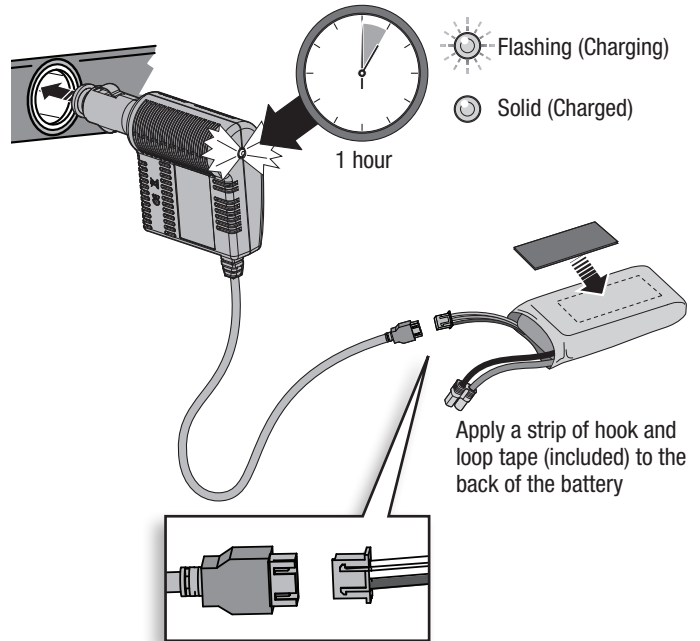

Apply a strip of hook and loop tape (included) to the back of the battery

RTF DX4e Transmitter

READY-TO-FLY

Remove the battery cover, install the four included batteries (noting proper polarity) and reinstall the battery cover.

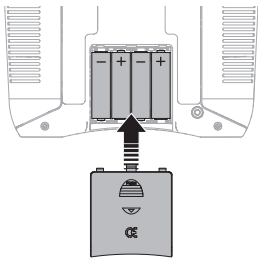

Low Battery Alarm

When the battery voltage drops below 4.7 volts, an alarm sounds and the voltage LEDs flash. The batteries must be replaced immediately. If this happens while flying, land your aircraft as soon and as safely as possible.



WARNING: Do not pick up the transmitter by the antenna. Do not alter or put weight on the antenna. Damage to antenna parts can decrease transmitter signal strength, which can result in loss of model control, injury or property damage.

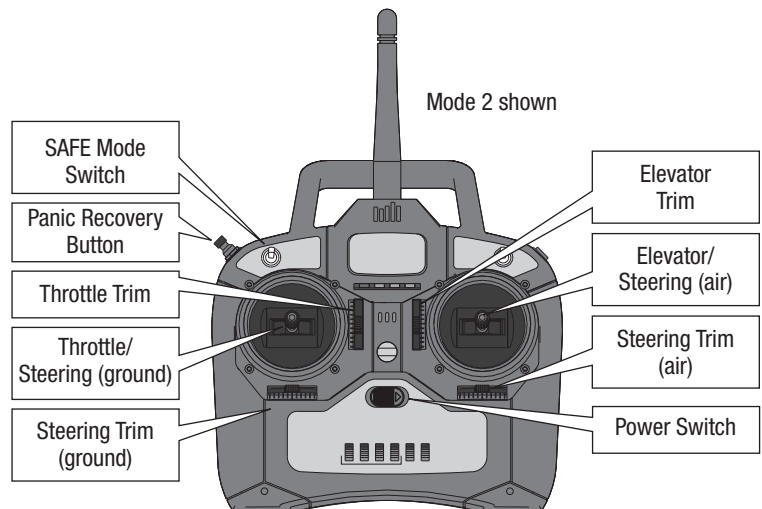

Center the Trims on your RTF DX4e before flight.

For more information on the transmitter, go to www.horizonhobby.com/products/SPMR4400 and click on the support tab for the Spektrum DX4e to download the instruction manual.



Your Delta Ray should already be bound to your included DX4E TX. If you ever need to rebind, follow the step listed below in the Binding Procedure Reference Table.

- SAFE Flight mode is selected using Channel 5 signal (high, middle, low)
- Panic mode is selected with Channel 6 signal (high, low)
- Refer to your transmitter's manual for more information about transmitter setup

N = Normal R = Reverse

Transmitter	Thro	Aile	Elev	Rudd	Gear/ Ch 5	Aux 1	Flight Mode/ Panic Switch	SAFE Flight Modes Supported
DX4e (2pos)	N	N	N	N	N	N/A	Default	2 pos Flight Mode
DX4e (3pos)	N	N	N	N	N	N/A	Default	3 pos Flight Mode
DX5e (2pos)	N	N	N	N	N	N/A	Default	2 pos Flight Mode
DX5e (3pos)	N	N	N	N	N	N/A	Default	3 pos Flight Mode
DX6i	N	N	N	N	R	N	(Flap System) Norm UP Arrow 100 Land Down Arrow 100	2 pos Flight Mode
DX7	N	N	N	N	N	N	(Flap System) Norm Down Mid 0 Land UP 100 (3 pos Aux1 switch-0 & 1 are normal, 2 is panic)	2 pos Flight Mode
DX7s	N	N	N	N	N	R	(Switch Select) Gear to INH, FM to INH, Flap to Gear, Trainer to Aux1	3 pos Flight Mode
DX8	N	N	N	N	N	R	(Switch Select) Gear to INH, FM to Gear, Flap to INH, Trainer to Aux 1	3 pos Flight Mode
DX9	N	N	N	N	N	R	(Channel Input Config) Gear is B, Aux1 is switch i	3 pos Flight Mode
DX10t	N	N	N	N	N	R	(Channel Input Config) Gear is A, Aux1 is R stick	3 pos Flight Mode
DX18	N	N	N	N	N	R	(Channel Input Config) Gear is B, Aux1 is switch i	3 pos Flight Mode



Setup for Optional Transmitter

To operate the SAFETM system in this aircraft, set up your optional DSM2®/DSMX® transmitter using the chart below.

A transmitter with a 2-position channel 5 switch will only allow the use of position 0 or position 2 flight modes. If possible, assign channel 5 in your transmitter to a 3-position switch to operate all 3 flight modes.

✓ Binding Procedure Reference Table

1. Make sure the transmitter is powered off.
2. Make sure the transmitter controls are neutral, the throttle and throttle trim are in the low position, and the aircraft is immobile.
3. Install a bind plug in the receiver bind port.
4. Connect the flight battery in the aircraft. The receiver LED will begin to flash.
5. Power on the transmitter while holding the transmitter bind button.
6. When the receiver binds to the transmitter, the light on the receiver will turn solid and produce a series of three ascending tones. The tones will indicate the ESC is armed, provided the throttle stick and throttle trim are low enough to trigger arming.
7. Release the Bind button and remove the bind plug from the receiver.
8. Confirm that the aircraft is bound by moving controls.

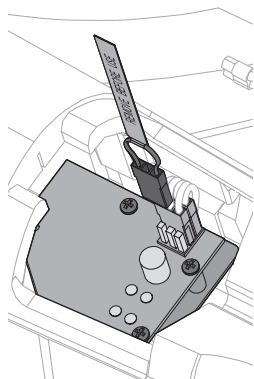

The receiver should retain the binding instructions received from the transmitter until another binding is done.



Transmitter and Receiver Binding

Binding is the process of programming the receiver to recognize the GUID (Globally Unique Identifier) code of a single specific transmitter.

You need to 'bind' your chosen Spektrum™ DSM2/DSMX technology equipped aircraft transmitter to the receiver for proper operation.

Please visit www.bindnfly.com for a complete list of compatible transmitters.

Wingtip and Vertical Fin Installation

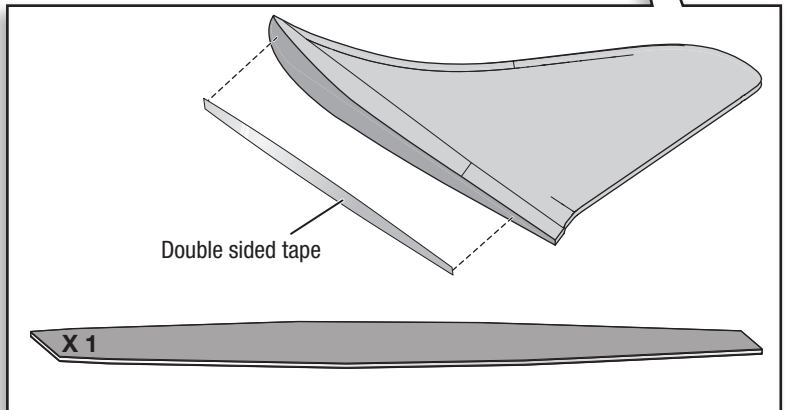
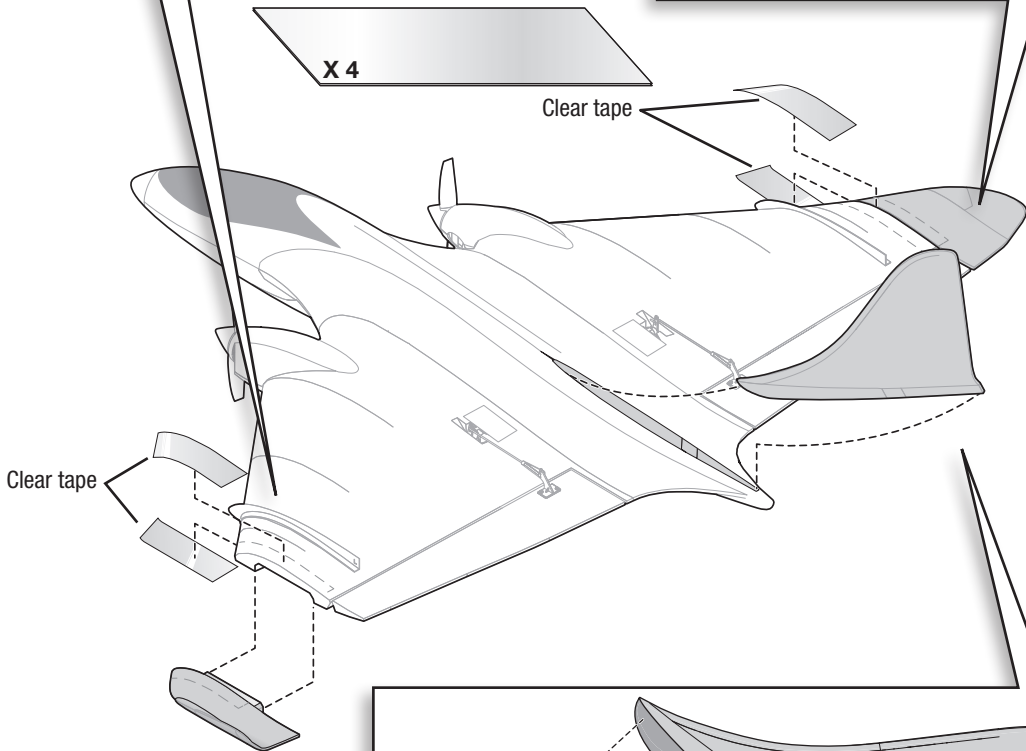
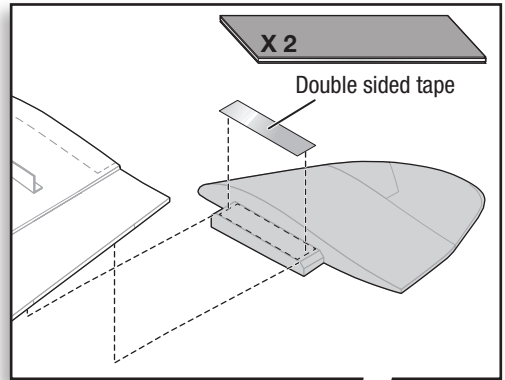
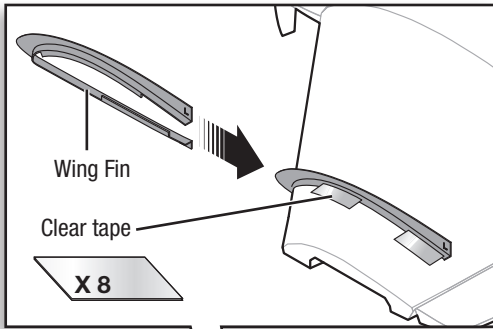

Lower the throttle and throttle trim, then power on the transmitter for at least 5 seconds.

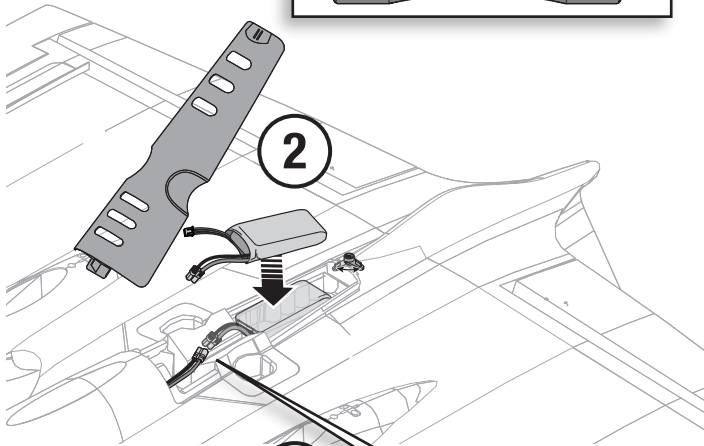
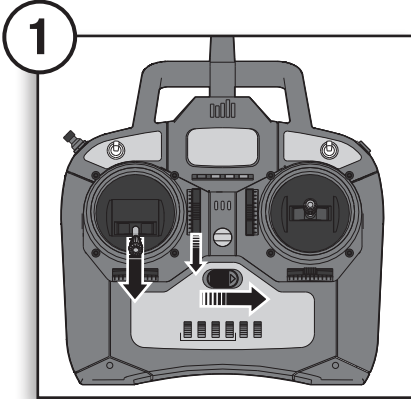

The elevons will move, then return to center, showing the aircraft is ready to fly.

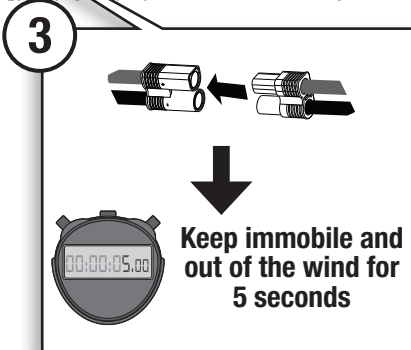

Installing the Flight Battery

CAUTION: Always disconnect the Li-Po flight battery from the aircraft receiver when not flying to avoid over-discharging the battery. Batteries discharged to a voltage lower than the lowest approved voltage may become damaged, resulting in loss of performance and potential fire when batteries are charged.

CAUTION: Always keep hands away from the propellers. SAFE technology will turn propellers in response to any aircraft movement.

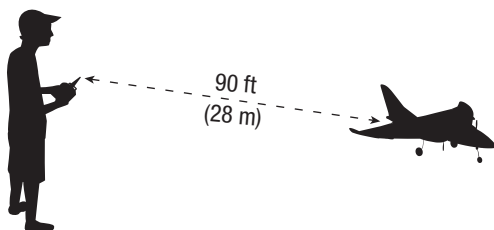

Range Test

Before each flying session, and especially with a new model, you should perform a range check. Refer to your transmitter manual for more information.

Control Direction Test

Perform the Control Direction Test with the transmitter's SAFE flight mode switch set to **Experienced** mode (position 2).

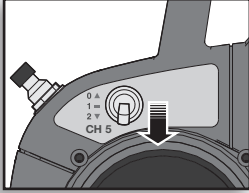

Experienced SAFE
Flight Mode

Restrain the aircraft so it does not escape your control while you are testing your transmitter controls.

Move the sticks on the transmitter to ensure the aircraft responds as shown.

If your model does not respond as shown, DO NOT FLY! Refer to the Troubleshooting Guide in this manual for more information. If you need more assistance, contact the appropriate Horizon Hobby Product Support department.

If the aircraft responds as shown, move the SAFE flight mode switch to **Beginner** mode (position 0) and center all trims to prepare to fly.

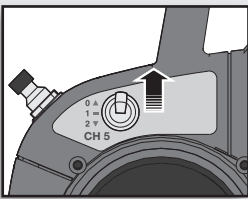

Beginner SAFE Flight Mode

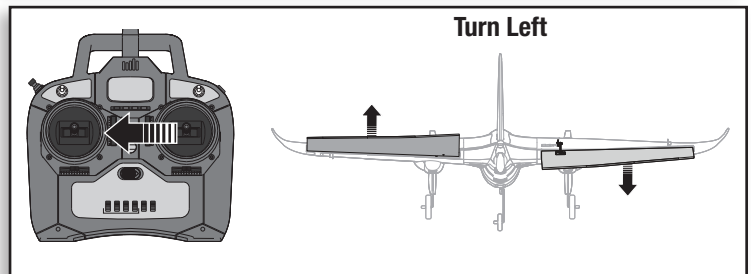
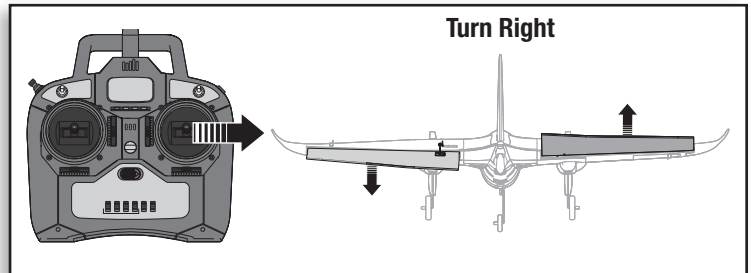
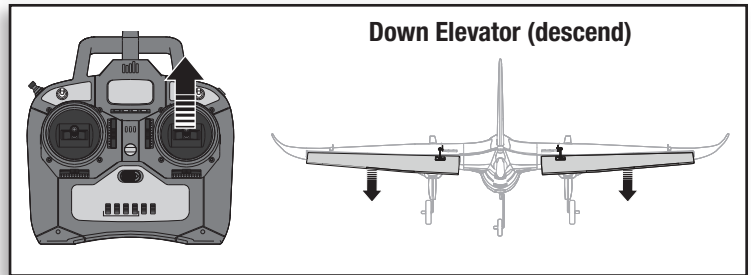
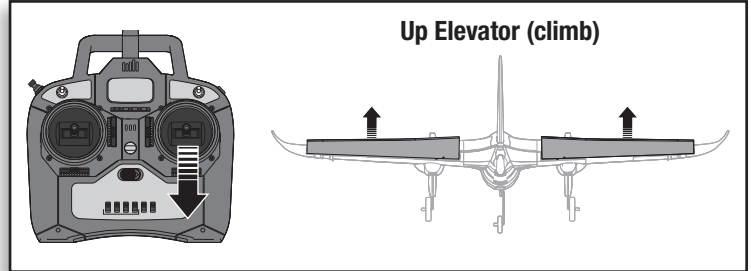

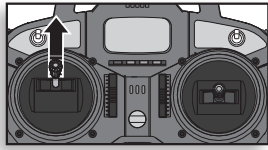

Climbs at 100% throttle

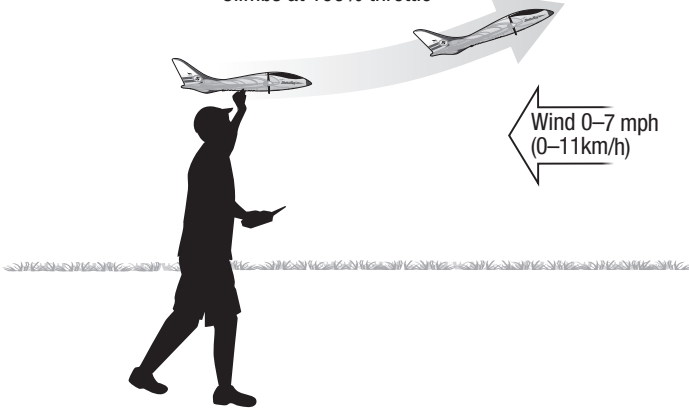

Takeoff

Hand Launch

Hand launch in Beginner mode for first flights. Get help to hand launch your aircraft so you can concentrate on flying. If you must hand launch the aircraft alone, hold the model in your dominant hand and the transmitter in your other hand. An optional neck strap (SPMP610, sold separately) can help you hold the transmitter.

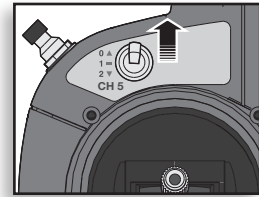

Beginner SAFE Mode
(Switch Position 0)

Ground Launch

Install the landing gear as shown.

Use the Beginner mode for takeoff in first flights. If the ground is not hard and level, get help to hand launch your aircraft.

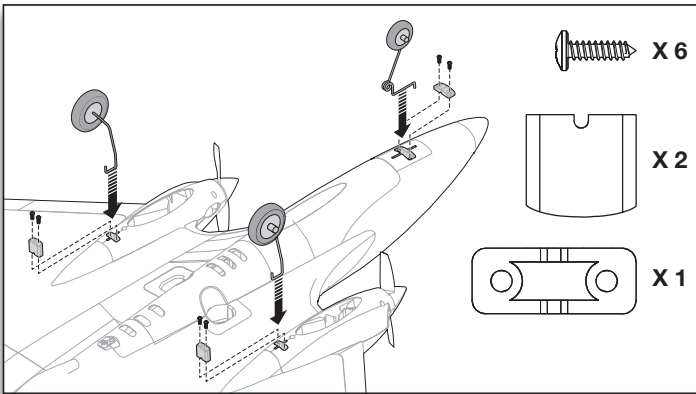

Easy Launching

Launching is easier in Beginner mode if you hold the Panic Recovery button. Press and hold the button, then increase the throttle to 100%. Launch the aircraft. When the aircraft is up where you want to fly, release the button and decrease the throttle to 50–60%.

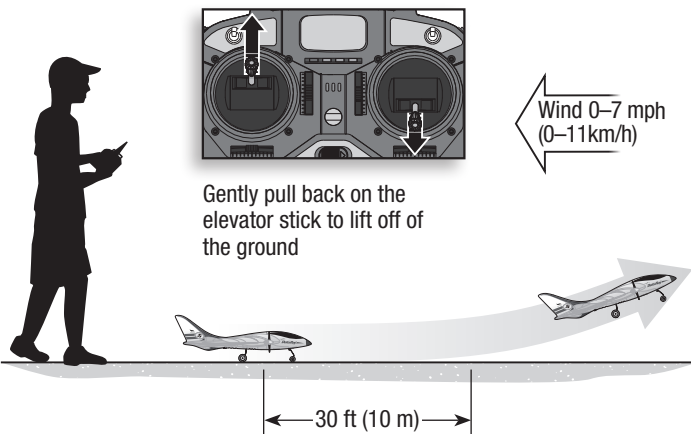
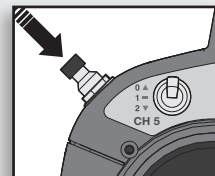

Gently pull back on the elevator stick to lift off of the ground

Flying

- In Beginner mode, when properly trimmed, your aircraft will climb at full throttle without use of the elevator stick.
- Make small and steady control stick movements for smooth control of your aircraft.
- Let the aircraft climb at full throttle, into the wind, until the aircraft gets about 150 feet (46 meters) above the ground, then decrease the throttle to half (50%).
- Flying with the nose pointed toward you is one of the hardest things to do when learning to fly. To practice piloting the aircraft, try flying in large circles high off the ground.

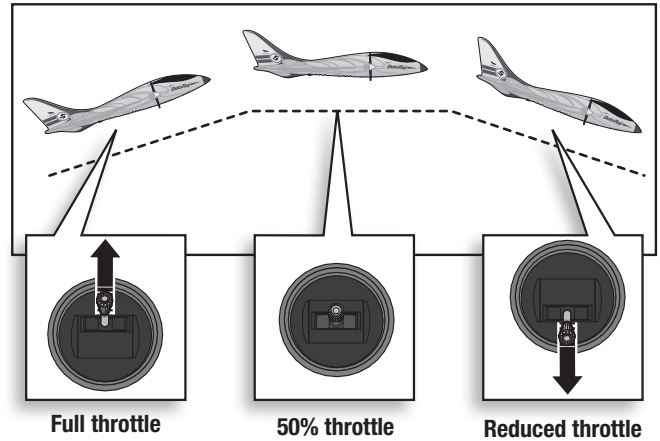

SAFE™ Technology Flight Modes

Beginner Mode:

Pitch (nose up and down) and Roll (wing tips up and down) angles are limited to help you keep the aircraft airborne

Self-leveling

Intermediate Mode:

The pilot is only prevented from entering extreme flight conditions

Experienced Mode

Unlimited Flight Envelope

Panic Recovery

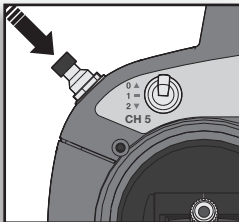

If you feel you have lost control in any mode, hold the Panic Recovery button. The SAFE technology will return the aircraft to a stable attitude (wings level with a slight climb). Always fly at a safe altitude, as Panic Recovery may cause the aircraft to lose some altitude when leveling the wings. Release the Panic Recovery button to turn off Panic mode and return to the current SAFE flight mode.

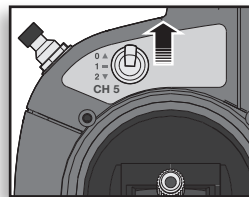

Beginner Mode
(Switch Position 0)

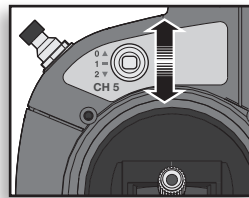

Intermediate Mode
(Switch Position 1)

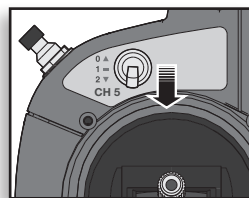

Experienced Mode
(Switch Position 2)

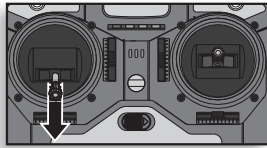

Descends at 0% throttle

Wind 0–7 mph
(0–11km/h)

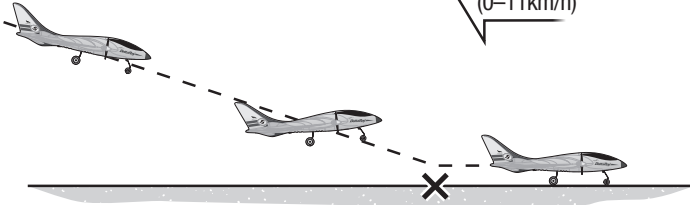

⚠ WARNING

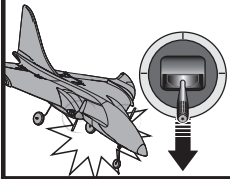

Always
decrease throttle at
propeller strike.

Landing

Land the aircraft in Beginner mode.

CAUTION: Never catch a flying aircraft in your hands. Doing so could cause personal injury and damage to the aircraft.



Easy Landing

Landing is easier if you hold the Panic Recovery button. Line up for your landing, decrease the throttle to 0% and press and hold the Panic Recovery button. The aircraft will glide down wings level with the nose up (flared) for landing.

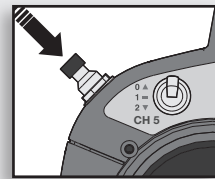

NOTICE: If a crash is imminent, reduce the throttle. Failure to do so could result in extra damage to the airframe, as well as damage to the receiver and motors.

NOTICE: Crash damage is not covered under warranty.

Post Flight Checklist



- | | |
|---|--|
| 1. Disconnect flight battery from aircraft (Required for Safety). | |
| 2. Remove flight battery from the aircraft. | |
| 3. Power off transmitter. | |
| 4. Recharge flight battery. | |
| 5. Repair or replace all damaged parts. | |
| 6. Store flight battery apart from the aircraft and monitor the battery charge. | |
| 7. Make note of flight conditions and flight plan results, planning for future flights. | |

Post Flight

NOTICE: When you are finished flying, never leave the aircraft in direct sunlight or in a hot, enclosed area such as a car. Doing so can damage the foam.

Adjusting Trim in Flight

Move the trim sliders for the controls as they are assigned on your transmitter. Familiarize yourself with your transmitter's controls and the aircraft's response before flying by performing the recommended Control Direction Test.

Elevator trim:

Trim the elevator at 50%-60% throttle. When the elevator is trimmed correctly, your aircraft will fly level at half throttle, climb steadily above half throttle and descend below half throttle.







- If the aircraft's nose drifts up or down while the elevator stick is at neutral (centered) position, move the elevator trim slider by one or two "click" increments in the SAME direction as the drift.

Aileron trim:

When trimmed correctly, your aircraft flies with wings level.

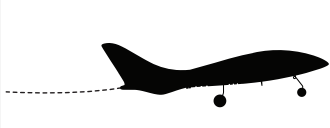
- If the aircraft drifts left or right when the aileron stick is at neutral (centered) position, move the aileron trim slider by one or two "click" increments OPPOSITE the direction of roll.

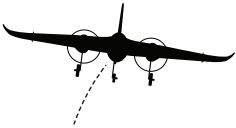
If you must use more than 8 "clicks" on a trim slider to make the aircraft fly straight and level, land and adjust a control surface as described below.

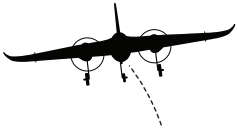
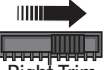
	Aircraft drift	Required Trim
Elevator		 Up Trim
		 Down Trim
Aileron		 Left Trim
		 Right Trim

Manually Adjusting Trim

Perform manual adjustment of trim before increasing the throttle above 25% or SAFE will move the control surfaces when the aircraft is moved.

Return any trim setting on the transmitter to neutral by pushing the trim slider to the middle position, then adjusting the clevis on that control surface to position it the same as it was with the trim slider offset.

1. Remove the clevis from the control horn.
2. Turn the clevis (as shown) to lengthen or shorten the pushrod.
3. Close the clevis onto the control horn and slide the tube towards the horn to secure the clevis.

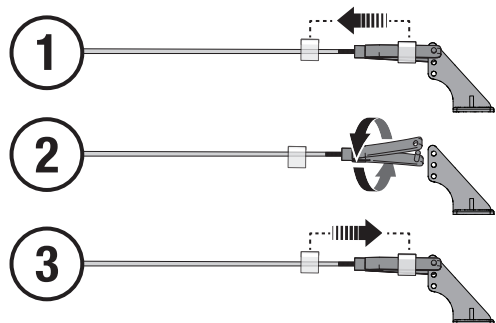

Troubleshooting Guide

Problem	Possible Cause	Solution
Oscillation	Flying over recommended airspeed	Reduce air speed
	Damaged propeller or spinner	Replace propeller or spinner
	Motor vibration	Replace parts or correctly align all parts and tighten fasteners as needed
	Loose receiver	Align and secure receiver in fuselage
	Loose aircraft controls	Tighten or otherwise secure parts (servo, arm, linkage, horn and control surface)
Trim is at extreme and aircraft does not fly straight or level	Worn parts	Adjust gain to compensate for parts wear or replace worn parts (especially propeller, pivot points or servo)
Aircraft will not respond to throttle but responds to other controls	Trim is not at neutral	If you adjust trim more than 8 clicks, adjust the clevis to mechanically remove trim
	Throttle not at lowest position or throttle trim too high	Reset controls with throttle stick and throttle trim at lowest setting
	Throttle channel is reversed	Reverse throttle channel on transmitter
Extra propeller noise or extra vibration	Motors disconnected from ESCs	Make sure motors are connected to the ESCs
	Damaged propeller and spinner, collet or motor	Replace damaged parts
	Propeller is out of balance	Balance or replace propeller
Reduced flight time or aircraft underpowered	Spinner is damaged or loose	Repair or replace damaged spinner
	Flight battery charge is low	Completely recharge flight battery
	Propeller installed backwards	Install propeller with numbers facing forward
	Propellers are installed incorrectly	Install propeller marked R on right and propeller marked L on the left
	Flight battery damaged	Replace flight battery and follow flight battery instructions
Aircraft will not Bind (during binding) to transmitter. Refer to the transmitter manual for binding instructions.	Flight conditions may be too cold	Make sure battery is warm before use
	Transmitter too near aircraft during binding process	Move powered transmitter a few feet from aircraft, disconnect and reconnect flight battery to aircraft
	Aircraft or transmitter is too close to large metal object, wireless source or another transmitter	Move aircraft and transmitter to another location and attempt binding again
	Flight battery/transmitter battery charge is too low	Replace/recharge batteries
Aircraft will not connect (after binding) to transmitter. Refer to the transmitter manual for binding instructions.	Bind switch or button not held long enough during bind process	Power off transmitter and repeat bind process. Hold transmitter bind button or switch until receiver is bound
	Transmitter too near aircraft during connecting process	Move powered transmitter a few feet from aircraft, disconnect and reconnect flight battery to aircraft
	Aircraft or transmitter is too close to large metal object, wireless source or another transmitter	Move aircraft and transmitter to another location and attempt connecting again
	Flight battery/Transmitter battery charge is too low	Replace/recharge batteries
Control surface does not move	Transmitter may have been bound to a different aircraft using different DSM protocol	Bind aircraft to transmitter
	Control surface, control horn, linkage or servo damage	Replace or repair damaged parts and adjust controls
	Wire damaged or connections loose	Do a check of wires and connections, connect or replace as needed
	Flight battery charge is low	Fully recharge flight battery
Controls reversed	Receiver is damaged	Replace Receiver
Motor power pulses then motor loses power	Transmitter settings are reversed	Perform the Control Direction Test and adjust the controls on transmitter appropriately
	Normal Low Voltage Cutoff (LVC)	Recharge flight battery or replace battery that is no longer performing
	Weather conditions might be too cold	Postpone flight until weather is warmer
	Battery is old, worn out, or damaged	Replace battery
	Battery C rating might be too small	Use recommended battery

Service and Repair

Thanks to the Z-Foam™ material in the wing and fuselage of this aircraft, repairs to the foam can be made using virtually any adhesive (hot glue, regular CA [cyanoacrylate adhesive], epoxy, etc).

When parts are not repairable, see the Replacement Parts List for ordering by item number. For a listing of all replacement and optional parts, refer to the list at the back of this manual.



CAUTION: DO NOT handle a propeller, motor or ESC while the flight battery is connected to the ESC. Personal injury could result.

Disassembly

1. Remove the spinner (A) by carefully pulling it away from the propeller (B).
2. Hold the motor shaft (C) in place, then pull the propeller from the motor shaft.
3. Remove 3 screws (D) from the motor cowling under the wing.
4. Remove the cowling (that contains the motor) from the wing. Paint may keep the cowling attached to the wing.
5. Remove 2 screws (E) from the front of the cowling that secures the motor.
6. Disconnect the motor wires from the ESC wires.
7. Remove the motor (F) and motor wires from the wing.
8. Assemble in reverse order.
9. Correctly center and attach the spinner to the propeller hub using CA (cyanoacrylate adhesive).

NOTICE: Make sure the propeller size numbers (4.75x2.5R for right side and 4.75X2.5L for left side) face out from the motor.

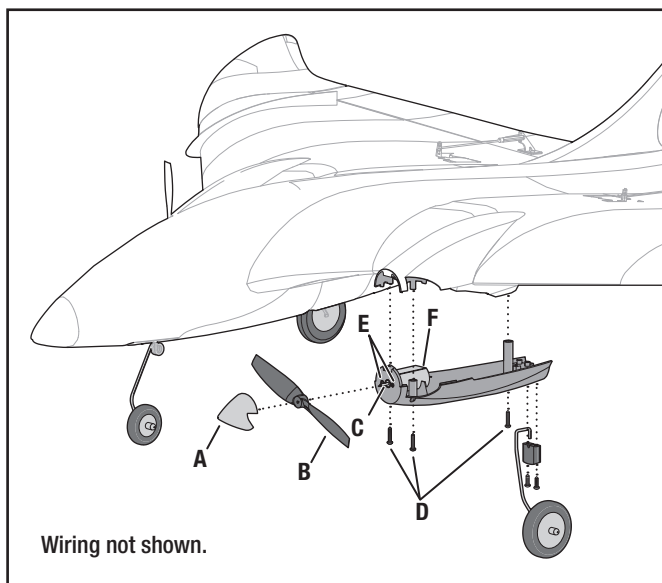

Prolong Battery Life

1. Low Voltage Cutoff (LVC) pulses the power to the motors when the voltage gets low. When the motors pulse, land the aircraft immediately and recharge the flight battery.
2. The aircraft can fly as recommended for approximately 8 minutes on one battery charge. Set a timer or stopwatch to let you know when it is time to land. However, if the motor begins to pulse (hits LVC), land immediately.

NOTICE: Repeated flying to LVC will damage the battery.

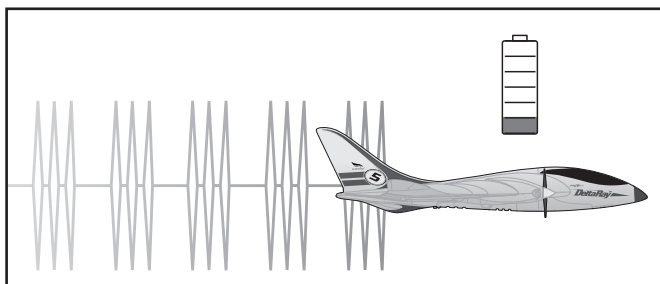

Limited Warranty

What this Warranty Covers

Horizon Hobby, Inc., (Horizon) warrants to the original purchaser that the product purchased (the "Product") will be free from defects in materials and workmanship at the date of purchase.

What is Not Covered

This warranty is not transferable and does not cover (i) cosmetic damage, (ii) damage due to acts of God, accident, misuse, abuse, negligence, commercial use, or due to improper use, installation, operation or maintenance, (iii) modification of or to any part of the Product, (iv) attempted service by anyone other than a Horizon Hobby authorized service center, (v) Product not purchased from an authorized Horizon dealer, or (vi) Product not compliant with applicable technical regulations.

OTHER THAN THE EXPRESS WARRANTY ABOVE, HORIZON MAKES NO OTHER WARRANTY OR REPRESENTATION, AND HEREBY DISCLAIMS ANY AND ALL IMPLIED WARRANTIES, INCLUDING, WITHOUT LIMITATION, THE IMPLIED WARRANTIES OF NON-INFRINGEMENT, MERCHANTABILITY AND FITNESS FOR A PARTICULAR PURPOSE. THE PURCHASER ACKNOWLEDGES THAT THEY ALONE HAVE DETERMINED THAT THE PRODUCT WILL SUITABLY MEET THE REQUIREMENTS OF THE PURCHASER'S INTENDED USE.

Purchaser's Remedy

Horizon's sole obligation and purchaser's sole and exclusive remedy shall be that Horizon will, at its option, either (i) service, or (ii) replace, any Product determined by Horizon to be defective. Horizon reserves the right to inspect any and all Product(s) involved in a warranty claim. Service or replacement decisions are at the sole discretion of Horizon. Proof of purchase is required for all warranty claims. SERVICE OR REPLACEMENT AS PROVIDED UNDER THIS WARRANTY IS THE PURCHASER'S SOLE AND EXCLUSIVE REMEDY.

Limitation of Liability

HORIZON SHALL NOT BE LIABLE FOR SPECIAL, INDIRECT, INCIDENTAL OR CONSEQUENTIAL DAMAGES, LOSS OF PROFITS OR PRODUCTION OR COMMERCIAL LOSS IN ANY WAY, REGARDLESS OF WHETHER SUCH CLAIM IS BASED IN CONTRACT, WARRANTY, TORT, NEGLIGENCE, STRICT LIABILITY OR ANY OTHER THEORY OF LIABILITY, EVEN IF HORIZON HAS BEEN ADVISED OF THE POSSIBILITY OF SUCH DAMAGES. Further, in no event shall the liability of Horizon exceed the individual price of the Product on which liability is asserted. As Horizon has no control over use, setup, final assembly, modification or misuse, no liability shall be assumed nor accepted for any resulting damage or injury. By the act of use, setup or assembly, the user accepts all resulting liability. If you as the purchaser or user are not prepared to accept the liability associated with the use of the Product, purchaser is advised to return the Product immediately in new and unused condition to the place of purchase.

Law

These terms are governed by Illinois law (without regard to conflict of law principals). This warranty gives you specific legal rights, and you may also have other rights which vary from state to state. Horizon reserves the right to change or modify this warranty at any time without notice.

WARRANTY SERVICES

Questions, Assistance, and Services

Your local hobby store and/or place of purchase cannot provide warranty support or service. Once assembly, setup or use of the Product has been started, you must contact your local distributor or Horizon directly. This will enable Horizon to better answer your questions and service you in the event that you may need any assistance. For questions or assistance, please visit our website at www.horizonhobby.com, submit a Product Support Inquiry, or call the toll free telephone number referenced in the Warranty and Service Contact Information section to speak with a Product Support representative.

Inspection or Services

If this Product needs to be inspected or serviced and is compliant in the country you live and use the Product in, please use the Horizon Online Service Request submission process found on our website or call Horizon to obtain a Return Merchandise Authorization (RMA) number. Pack the Product securely using a shipping carton. Please note that original boxes may be included, but are not designed to withstand the rigors of shipping without additional protection. Ship via a carrier that provides tracking and insurance for lost or damaged parcels, as Horizon is not responsible for merchandise until it arrives and is accepted at our facility. An Online Service Request is available at http://www.horizonhobby.com/content/_service-center_render-service-center. If you do not have internet access, please contact Horizon Product Support to obtain a RMA number along with instructions for submitting your product for service. When calling Horizon, you will be asked to provide your complete name, street address, email address and phone number where you can be reached during business hours. When sending product into Horizon, please include your RMA number, a list of the included items, and a brief summary of the problem. A copy of your original sales receipt must be included for warranty consideration. Be sure your name, address, and RMA number are clearly written on the outside of the shipping carton.

NOTICE: Do not ship LiPo batteries to Horizon. If you have any issue with a LiPo battery, please contact the appropriate Horizon Product Support office.

Warranty Requirements

For Warranty consideration, you must include your original sales receipt verifying the proof-of-purchase date. Provided warranty conditions have been met, your Product will be serviced or replaced free of charge. Service or replacement decisions are at the sole discretion of Horizon.

Non-Warranty Service

Should your service not be covered by warranty, service will be completed and payment will be required without notification or estimate of the expense unless the expense exceeds 50% of the retail purchase cost. By submitting the item for service you are agreeing to payment of the service without notification. Service estimates are available upon request. You must include this request with your item submitted for service. Non-warranty service estimates will be billed a minimum of ½ hour of labor. In addition you will be billed for return freight. Horizon accepts money orders and cashier's checks, as well as Visa, MasterCard, American Express, and Discover cards. By submitting any item to Horizon for service, you are agreeing to Horizon's Terms and Conditions found on our website http://www.horizonhobby.com/content/_service-center_render-service-center.

ATTENTION: Horizon service is limited to Product compliant in the country of use and ownership. If received, a non-compliant Product will not be serviced. Further, the sender will be responsible for arranging return shipment of the un-serviced Product, through a carrier of the sender's choice and at the sender's expense. Horizon will hold non-compliant Product for a period of 60 days from notification, after which it will be discarded.

Warranty and Service Contact Information

Country of Purchase	Horizon Hobby	Contact Information	Address
United States of America	Horizon Service Center (Repairs and Repair Requests)	servicecenter.horizonhobby.com/RequestForm/	4105 Fieldstone Rd Champaign, Illinois, 61822 USA
	Horizon Product Support (Product Technical Assistance)	www.quickbase.com/db/bghj7ey8c?a=GenNewRecord Air 888-959-2305	
	Sales	sales@horizonhobby.com Air 888-959-2305	
United Kingdom	Service/Parts/Sales: Horizon Hobby Limited	sales@horizonhobby.co.uk +44 (0) 1279 641 097	Units 1-4 , Ployters Rd, Staple Tye Harlow, Essex, CM18 7NS, United Kingdom
Germany	Horizon Technischer Service Sales: Horizon Hobby GmbH	service@horizonhobby.de +49 (0) 4121 2655 100	Christian-Junge-Straße 1 25337 Elmshorn, Germany
France	Service/Parts/Sales: Horizon Hobby SAS	infofrance@horizonhobby.com +33 (0) 1 60 18 34 90	11 Rue Georges Charpak 77127 Lieusaint, France
China	Service/Parts/Sales: Horizon Hobby – China	info@horizonhobby.com.cn +86 (021) 5180 9868	Room 506, No. 97 Changshou Rd. Shanghai, China 200060

FCC Information

Operation is subject to the following two conditions: (1) This device may not cause harmful interference, and (2) this device must accept any interference received, including interference that may cause undesired operation.

CAUTION: Changes or modifications not expressly approved by the party responsible for compliance could void the user's authority to operate the equipment.

This product contains a radio transmitter with wireless technology which has been tested and found to be compliant with the applicable regulations governing a radio transmitter in the 2.400GHz to 2.4835GHz frequency range.

Antenna Separation Distance

When operating your transmitter, please be sure to maintain a separation distance of at least 5 cm between your body (excluding fingers, hands, wrists, ankles and feet) and the antenna to meet RF exposure safety requirements as determined by FCC regulations.

This illustration show the approximate 5 cm RF exposure area and typical hand placement when operating your transmitter.

IC Information

This device complies with Industry Canada licence-exempt RSS standard(s). Operation is subject to the following two conditions: (1) this device may not cause interference, and (2) this device must accept any interference that may cause undesired operation of the device.

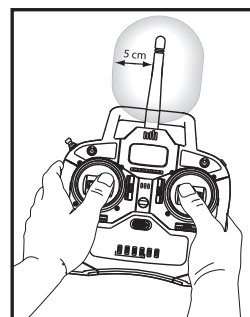

Compliance Information for the European Union

AT	BE	BG	CZ	CY	DE	DK
EE	ES	FI	FR	GR	HR	HU
IE	IT	LT	LU	LV	MT	NL
PL	PT	RO	SE	SI	SK	UK
IS	LI	NO	CH			

Declaration of Conformity

(in accordance with ISO/IEC 17050-1)

No. HH2013071101

Product(s): HBZ Delta Ray RTF
 Item Number(s): HBZ7900
 Equipment class: 2

The object of declaration described above is in conformity with the requirements of the specifications listed below, following the provisions of the European R&TTE directive 1999/5/EC, EMC Directive 2004/108/EC and LVD Directive 2006/95/EC:

EN 300-328 V1.7.1: 2006

EN 301 489-1 V1.9.2: 2012

EN 301 489-17 V2.1.1: 2009

EN60950-1:2006+A11:2009+A1:2010+A12: 2011

EN55022:2010 + AC:2011

EN55024:2010



Signed for and on behalf of:
 Horizon Hobby, Inc.
 Champaign, IL USA
 Jul 11, 2013

Robert Peak
 Chief Financial Officer
 Horizon Hobby, Inc

Declaration of Conformity

(in accordance with ISO/IEC 17050-1)

No. HH2014010403

Product(s): HBZ Delta Ray BNF
 Item Number(s): HBZ7980
 Equipment class: 1

The object of declaration described above is in conformity with the requirements of the specifications listed below, following the provisions of the European R&TTE directive 1999/5/EC, EMC Directive 2004/108/EC and LVD Directive 2006/95/EC:

EN 301 489-1 V1.9.2: 2012

EN 301 489-17 V2.1.1: 2009

EN60950-1:2006+A11:2009+A1:2010+A12: 2011

EN55022:2010 + AC:2011

EN55024:2010



Signed for and on behalf of:
 Horizon Hobby, Inc.
 Champaign, IL USA
 Jan 04, 2014

Robert Peak
 Chief Financial Officer
 Horizon Hobby, Inc



Instructions for disposal of WEEE by users in the European Union

This product must not be disposed of with other waste. Instead, it is the user's responsibility to dispose of their waste equipment by handing it over to a designated collections point for the recycling of waste electrical and electronic equipment. The separate collection and recycling of your waste equipment at the time of disposal will help to conserve natural resources and ensure that it is recycled in a manner that protects human health and the environment. For more information about where you can drop off your waste equipment for recycling, please contact your local city office, your household waste disposal service or where you purchased the product.

Replacement Parts • Ersatzteile • Pièces de rechange • Pezzi di ricambio

Part # Nummer Numéro Codice	Description	Beschreibung	Description	Descrizione
HBZ7925	Fin /Wing TipSet: Delta Ray	HobbyZone Firebird Delta Ray: Finnenset	Delta Ray - Dérive/extrémités d'ailes	Set impenn/tip alari: Delta Ray
HBZ7926	Motor Fairing Set: Delta Ray	HobbyZone Firebird Delta Ray: Motorverkleidung	Delta Ray - Set de carénages moteur	Set carenatura motore: Delta Ray
HBZ7985	Bare Fuselage: Firebird Delta Ray	HobbyZone Firebird Delta Ray: Rumpf o. Einbauten	Delta Ray - Fuselage nu	Solo fusoliera: Delta Ray
HBZ7918	Landing Gear Set: Delta Ray	HobbyZone Firebird Delta Ray: Fahrwerk und Kufenset	Delta Ray - Train d'atterrissage	Set carrello: Delta Ray
HBZ7909	Pushrod/Horn Set: Delta Ray	HobbyZone Firebird Delta Ray: Gestänge	Delta Ray - Set de guignols et tringleries	Set comandi/squadrette: Delta Ray
HBZ7907	Spinner&Prop Set: Delta Ray	HobbyZone Firebird Delta Ray: Gestänge	Delta Ray - Set d'hélice et de cônes	Set ogiva & elica: Delta Ray
HBZ7912	Belly Hatch: Delta Ray	HobbyZone Firebird Delta Ray: Rumpflappe unten	Delta Ray - Trappe à batterie	Portello ventrale: Delta Ray
HBZ7952	Rubber Nose: Delta Ray	HobbyZone Firebird Delta Ray: Rumpflappe unten	Delta Ray - Nez en caoutchouc	Naso in gomma: Delta Ray
HBZ7910	Decal Set: Delta Ray	HobbyZone Firebird Delta Ray: Dekorbogen	Delta Ray - Planche de décoration	Set adesivi: Delta Ray
SPMR4400	DX4e DSMX 4-Channel Full Range Tx only MD2/4	DX4e DSMX 4-Kanal nur Sender MD2/4	DX4e 4 voies DSMX Mode 2/4	Solo Tx 4 canali DX4e DSMX MD2/4
SPMR44001	DX4e DSMX 4-Channel Full Range Tx only MD1/3	DX4e DSMX 4-Kanal nur Sender MD1/3	DX4e 4 voies DSMX Mode 1/3	Solo Tx 4 canali DX4e DSMX MD1/3
HBZ7728	Brushed 180 Motor Set (2)	Hobbyzone Firebird Stratos Motor Set	Set de moteurs 180 à balais (2)	Set motore 180 con spazzole(2)
PKZ1080	(2) SV80 Long Lead Servo	Parkzone SV80 Servo	Servo SV80 (2)	(2) SV80 servo con cavo lungo
EFLC3125	2-Cell DC Balancing Li-Po Charger	2S DC Balancing Ladegerät	Chargeur équilibreur LI-Po DC 2S	Caricabatterie per 2 celle Li-Po con bilanciatore
EFLB13002S20	1300mAh 2S 7.4V 20C Li-Po, 13 AWG EC2 Battery	1300mAh 2S 7.4V 20C Li-Po, 13 AWG EC2 Akku	Batterie LI-Po 7.4V 2S 1300mA 20C, prise EC2	Batteria 1300mAh 2S 7.4V 20C Li-Po, 13 AWG EC2
SPMA3160	Delta Ray replacement receiver DSMX	HobbyZone Firebird Delta Ray: Ersatzempfänger DSMX	Delta Ray - Récepteur de remplacement DSMX	Delta Ray ricevitore di ricambio DSMX

Optional Parts • Optionale Bauteile • Pièces optionnelles • Pezzi opzionali

Part # Nummer Numéro Codice	Description	Beschreibung	Description	Descrizione
HBZ7920	Keychain Camera mount: Delta Ray	HobbyZone Firebird Delta Ray: Kamerahalter	Delta Ray - Support pour caméra porte clé	Supporto per telecamera tipo portachiavi Delta Ray
HBZ6513	Alligator Clip: 12V Lighter Adapter	Krokodilklemme: 12 V Zigarettenanzünder	Adaptateur 12V allume cigare/pinces croco	Pinze tipo coccodrillo: adattatore 12V per presa accendisigari
HBZ1004	1.5A AC Power Supply (US Only)	1.5A AC Power Supply (US Only)	Alimentation secteur 1.5A (USA uniquement)	1.5A AC Alimentatore (solo USA)
EFLA111	Li-Po Cell Voltage Checker	E-flite Li-Po Cell Volt Checker	Testeur de tension pour batterie Li-Po	Voltmetro per celle Li-Po
EFLA250	Park Flyer Tool Assortment, 5 pc	E-flite Park Flyer Werkzeugsortiment, 5 teilig	Assortiment d'outils pour park-flyer, 5 pièces	Assortimento attrezzi per Park Flyer
EFLAEC202	EC2 Battery Connector (2)	E-flite EC2 Akkubuchse (2)	Prise EC2 coté batterie (2)	EC2 Connettore batteria (2)
EFLAEC203	EC2 Device & Battery Connector	E-flite EC2 Stecker / Buchse	Prise EC2 coté contrôleur et coté batterie	EC2 dispositivo & connettore batteria
EFLC3025	Celectra 80W AC/DC Multi-Chemistry Battery Charger	Celectra 80 W AC/DC Multi-Chemistry-Batterieladegerät	Chargeur de batterie AC/DC Celectra 80 W multi-types	Caricabatterie per batteria multichimica 80 W c.a./c.c.



© 2013 Horizon Hobby, Inc.

HobbyZone, the HobbyZone logo, Delta Ray, SAFE, the SAFE logo, Z-Foam, DSM, DSM2, DSMX, EC2, Celectra and the Horizon Hobby logo are trademarks or registered trademarks of Horizon Hobby, Inc.

The outline and trim scheme of the Firebird Delta Ray were designed by Quique Somenzini in cooperation with Mirco Pecorari of Aircraft Studio Design.

The Spektrum trademark is used with permission of Bachmann Industries, Inc.

Patents Pending

www.hobbyzonerc.com

HBZ7900 / HBZ7980