

Name: _____ Date: _____ Event: _____
 City: _____ State: _____ Track: _____

Track Conditions: Indoor Tight Smooth Hard Packed Blue Groove Wet Grass Low Bite High Bite
 Outdoor Open Rough Loose/Loamy Dry Dusty Astro Turf Med Bite Other _____

Front Suspension

Toe: _____
 Ride Height: _____ Camber: _____
 Caster: 0° 5°
 Kick Angle: 20° 25° 30°
 VLA Setting: Short Arm Long Arm
 Front Pivot: Alum Plastic HRC Alum HRC
 Kick Shim: Brass Plastic
 Oil: _____
 Piston: _____
 Spring: Standard Low Freq. Color: _____
 Sway Bar: 0.8mm 1.0mm 1.2mm _____
 Shock Limiters: _____ Stroke: _____
 Shock Locations: _____
 Spindle Ball Stud: Standard Low Mount
 Bump Steer Spacers: _____
 Ackerman Ball Stud: Standard Low Mount
 Ackerman Spacers: _____
 Ackerman Arm: #1 #2 #3 _____
 Trail: 2mm 3mm 4mm
 Camber Link: _____

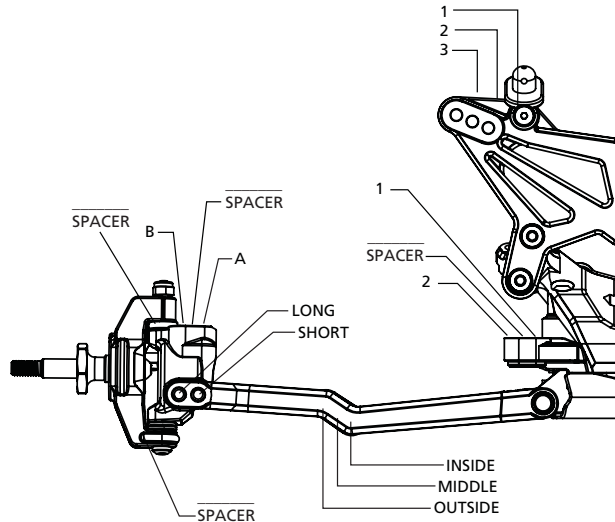

Notes: _____

Rear Suspension

Configuration: Laydown Standup
 LD Diff. Height: Standard +3.5mm
 Transmission Type: 3-Gear 4-Gear
 Toe Inserts: 0.5 1 1.5 2 2.5 3 3.5 4
 Anti-Squat Inserts: 0 0.5 1 1.5 2 2.5 3
 Inner Roll Center: LRC HRC
 Ride Height: _____ Camber: _____
 Rear Hub Spacing: _____
 Rear Axle Height: Standard +3mm
 Hex Width: _____
 Sway Bar: 1.0mm 1.2mm 1.4mm _____
 Oil: _____
 Piston: _____
 Spring: Standard Low Freq. Color: _____
 Shock Limiters: _____ Stroke: _____
 Shock Locations: _____
 Shock Mounting: Front Rear
 Inner Link Spacer: -1mm 0mm +1mm
 Camber Link: _____
 Battery Position: _____
 Diff Type: Ball Gear Setting: _____
 Driveshaft Length: CVA Universal Length: _____

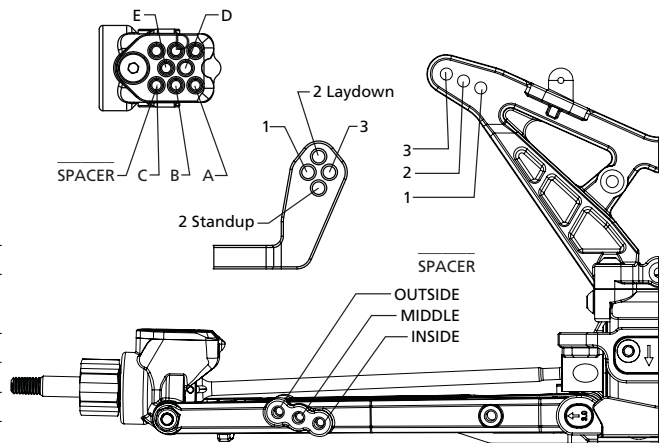

Electronics

Radio: _____ Timing Advance: _____
 Servo: _____ Throttle/Brake Expo: _____
 ESC: _____ Servo Expo: _____
 Initial Brake: _____ Throttle/Brake EPA: _____
 Drag Brake: _____ Motor: _____
 Throttle Profile: _____ Pinion: _____ Spur: _____
 Battery: _____

Chassis

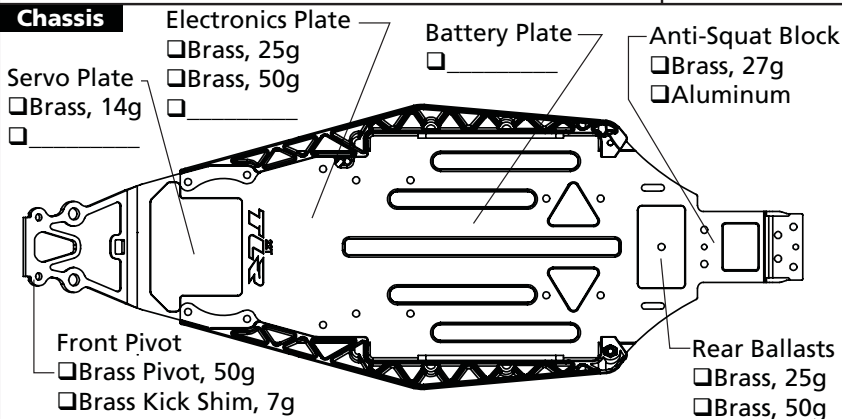

Servo Plate: Brass, 14g
 Electronics Plate: Brass, 25g Brass, 50g
 Battery Plate: _____
 Anti-Squat Block: Brass, 27g Aluminum
 Front Pivot: Brass Pivot, 50g Brass Kick Shim, 7g
 Rear Ballasts: Brass, 25g Brass, 50g

Tires

	Front	Rear
Tire:	_____	_____
Compound:	_____	_____
Insert:	_____	_____
Additive:	_____	_____
Notes:	_____	
