

HORIZON[®]
H O B B Y

Eflite[®]
ADVANCING ELECTRIC FLIGHT

Night Radian[®] FT 2.0m

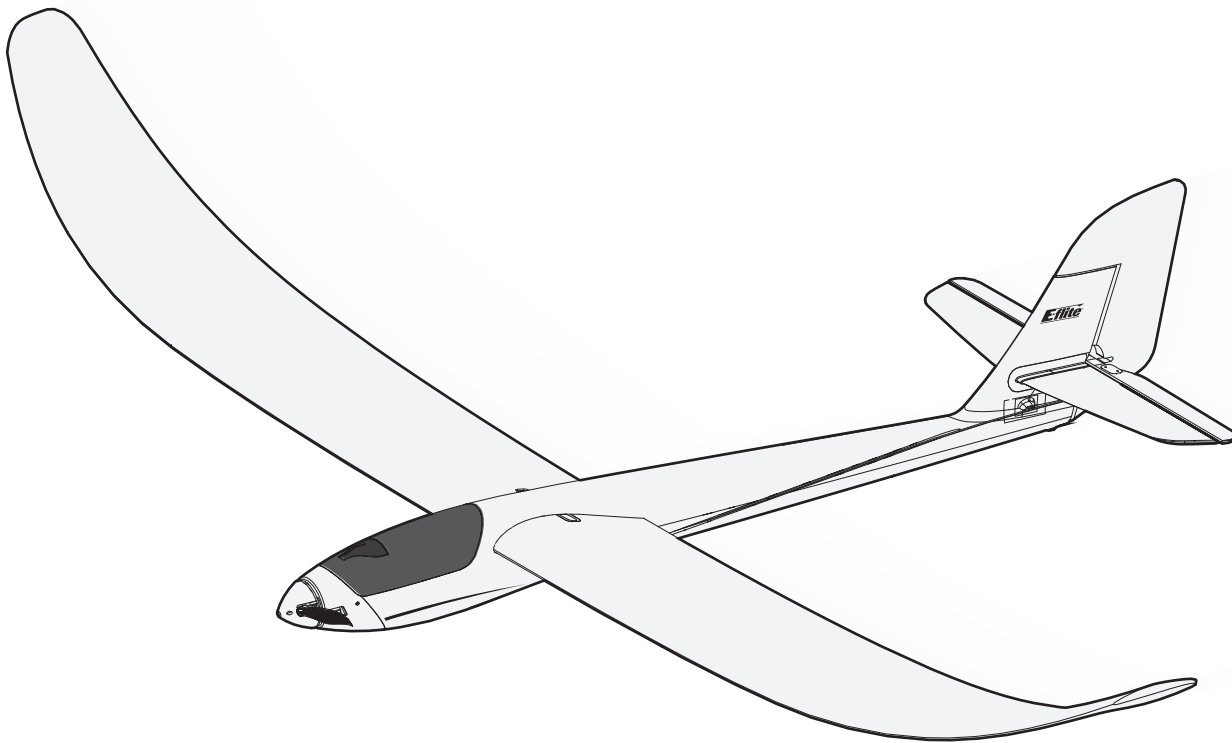

Instruction Manual
Bedienungsanleitung
Manuel d'utilisation
Manuale di Istruzioni

SAFE[®] 

SAFE[®] Select Technology, Optional Flight Envelope Protection

Bind-N-Fly[®] Plug-N-Play[®]
BASIC

NOTICE

All instructions, warranties and other collateral documents are subject to change at the sole discretion of Horizon Hobby, LLC. For up-to-date product literature, visit www.horizonhobby.com and click on the support tab for this product.

Meaning of Special Language:

The following terms are used throughout the product literature to indicate various levels of potential harm when operating this product:

WARNING: Procedures, which if not properly followed, create the probability of property damage, collateral damage, and serious injury OR create a high probability of superficial injury.

CAUTION: Procedures, which if not properly followed, create the probability of physical property damage AND a possibility of serious injury.

NOTICE: Procedures, which if not properly followed, create a possibility of physical property damage AND little or no possibility of injury.



WARNING: Read the ENTIRE instruction manual to become familiar with the features of the product before operating. Failure to operate the product correctly can result in damage to the product, personal property and cause serious injury.

This is a sophisticated hobby product. It must be operated with caution and common sense and requires some basic mechanical ability. Failure to operate this Product in a safe and responsible manner could result in injury or damage to the product or other property. This product is not intended for use by children without direct adult supervision. Do not use with incompatible components or alter this product in any way outside of the instructions provided by Horizon Hobby, LLC. This manual contains instructions for safety, operation and maintenance. It is essential to read and follow all the instructions and warnings in the manual, prior to assembly, setup or use, in order to operate correctly and avoid damage or serious injury.

14+

AGE RECOMMENDATION:
Not for children under 14 years. This is not a toy.



WARNING AGAINST COUNTERFEIT PRODUCTS: If you ever need to replace your Spektrum receiver found in a Horizon Hobby product, always purchase from Horizon Hobby, LLC or a Horizon Hobby authorized dealer to ensure authentic high-quality Spektrum product. Horizon Hobby, LLC disclaims all support and warranty with regards, but not limited to, compatibility and performance of counterfeit products or products claiming compatibility with DSM or Spektrum technology.

Safety Precautions and Warnings

As the user of this product, you are solely responsible for operating in a manner that does not endanger yourself and others or result in damage to the product or the property of others.

- Always keep a safe distance in all directions around your model to avoid collisions or injury. This model is controlled by a radio signal subject to interference from many sources outside your control. Interference can cause momentary loss of control.
- Always operate your model in open spaces away from full-size vehicles, traffic and people.
- Always carefully follow the directions and warnings for this and any optional support equipment (chargers, rechargeable battery packs, etc.).
- Always keep all chemicals, small parts and anything electrical out of the reach of children.
- Always avoid water exposure to all equipment not specifically designed and protected for this purpose. Moisture causes damage to electronics.
- Never place any portion of the model in your mouth as it could cause serious injury or even death.

- Never operate your model with low transmitter batteries.
- Always keep aircraft in sight and under control.
- Always use fully charged batteries.
- Always keep transmitter powered on while aircraft is powered.
- Always remove batteries before disassembly.
- Always keep moving parts clean.
- Always keep parts dry.
- Always let parts cool after use before touching.
- Always remove batteries after use.
- Always ensure failsafe is properly set before flying.
- Never operate aircraft with damaged wiring.
- Never touch moving parts.

Box Contents

Quick Start Information			
Transmitter Setup	Blank (Acro) Model		
	Servo Reversing: Rudder: Normal Elevator: Normal Aileron: Normal DO NOT Reverse Throttle		
Dual Rates	Dual Rates: 100% / 70%		
		Hi Rate	Low Rate
	Ele	▲=12mm ▼=12mm	▲=8mm ▼=8mm
	Rud	▶=35mm ◀=35mm	▶=25mm ◀=25mm
Center of Gravity (CG)	2 1/2 inches (63mm) back from leading edge at the root.		
Flight Timer Setting	7-10 minutes		

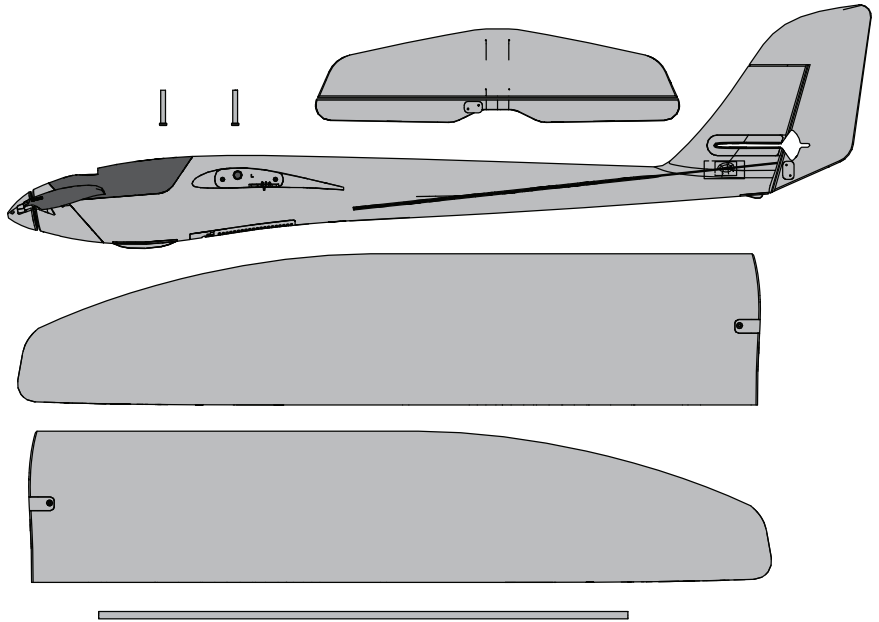

Specifications

		BNF BASIC EFL3650	PNP PLUG-N-PLAY EFL3675
	Motor: 480B BL Outrunner Motor; 960Kv Reverse Shaft PKZ4716	Installed	Installed
	ESC: 30A Brushless ESC (EFLA1030B)	Installed	Installed
	Servo: Mini Servo (3W) with Arms, Short Lead PKZ1060	Installed	Installed
	Receiver: Spektrum™ AR636 6-Ch AS3X Sport Receiver (SPMAR636)	Installed	Required to Complete
	Recommended Battery: 1350mAh 11.1V 30C Li-Po with EC3 Connector (EFLB13503S30)	Required to Complete	Required to Complete
	Recommended Battery Charger: 3-cell Li-Po battery balancing charger	Required to Complete	Required to Complete
	Recommended Transmitter: Full-Range 4 channel (or more) 2.4GHz with Spektrum™ DSM2®/DSMX® technology with adjustable Dual Rates.	Required to Complete	Required to Complete

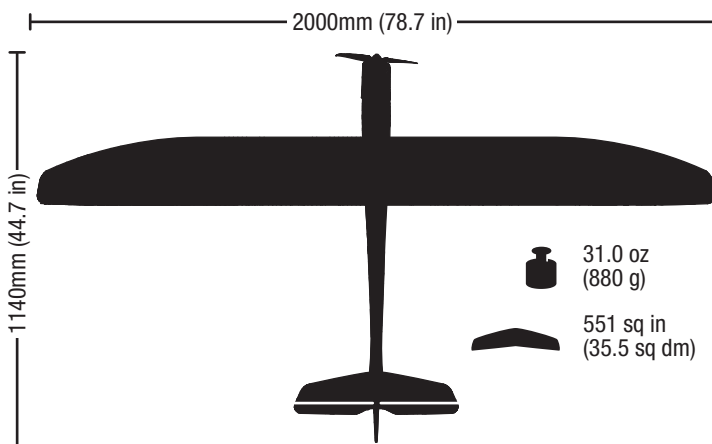

Table of Contents

SAFE® Select Technology (BNF Basic)	4
Preflight.....	4
Model Assembly	5
Control Horn and Servo Arm Settings	6
Binding / Switching ON and OFF SAFE Select.....	7
SAFE® Select Switch Designation.....	8
LED Controller.....	8
Battery Installation and ESC Arming	9
Center of Gravity (CG)	10
AS3X Control Direction Test.....	10
In Flight Trimming	11
Flying Tips and Repairs	11
Post Flight	12
Motor Service	12
PNP Receiver Selection and Installation	12
Troubleshooting Guide	13
AMA National Model Aircraft Safety Code	14
Limited Warranty	15
Contact Information	16
FCC Information.....	16
IC Information	16
Compliance Information for the European Union.....	16
Replacement Parts.....	58
Optional Parts	58
Recommended Receivers	59

RECEIVER BIND INFORMATION

Channels	6
Frequency	2405 – 2476 MHz
Compatibility	DSM2 and DSMX

To register your product online, visit www.e-fliterc.com

SAFE® Select Technology (BNF Basic)

The evolutionary SAFE® Select technology can offer an extra level of protection so you can perform the first flight with confidence. No complex transmitter programming is required. Just follow the simple bind process to make the SAFE Select system active. When activated, bank and pitch limitations keep you from over-controlling and automatic self-leveling makes recovery from risky or confusing attitudes as simple as releasing the sticks. In fact, with the aileron, elevator and rudder sticks in the neutral position, SAFE Select will automatically keep the airplane in a straight and level attitude.

Expand the advantage of what SAFE® Select technology offers by assigning it to a switch. No transmitter programming is required and you'll be able to turn the system ON and OFF with the flip of a switch. For example, turn SAFE select ON for takeoffs to counter the torque of the propeller. Turn it OFF in flight for unrestricted aerobatic performance, and turn it back ON when a buddy wants to try out your cool aircraft. Turn SAFE Select ON for landings. It will help keep the correct pitch attitude and wings level during the final approach. Whether you're a beginner or an expert, SAFE Select can make your flights a great experience.

When the normal bind process is followed, the SAFE Select system is disabled, leaving specially tuned AS3X® technology in place to deliver a pure, unrestricted flight experience.

Preflight

1	Remove and inspect contents.	8	Bind the aircraft to your transmitter.
2	Read this instruction manual thoroughly.	9	Make sure linkages move freely.
3	Charge the flight battery.	10	Perform the Control Direction Test with the transmitter.
4	Fully assemble the airplane.	11	Adjust flight controls and transmitter.
5	Install the flight battery in the aircraft (once it has been fully charged).	12	Perform a radio system Range Test.
6	Check the Center of Gravity (CG).	13	Find a safe open area to fly.
7	Apply Dual Rate values to your transmitter	14	Plan flight for flying field conditions.

Model Assembly

Tail Installation

1. Slide the horizontal stabilizer (A) into the slot of the fuselage.
2. Center the horizontal stabilizer and then secure into place with the 4 included pieces of tape (B).
3. Connect the LED connector on the bottom of the horizontal stabilizer.
4. Connect the clevis to the elevator control horn (C) as shown.

Connecting a Clevis

- Pull the tube from the clevis to the linkage.
- Carefully spread the clevis, then insert the clevis pin into the desired hole in the control horn.
- Move the tube to hold the clevis on the control horn.

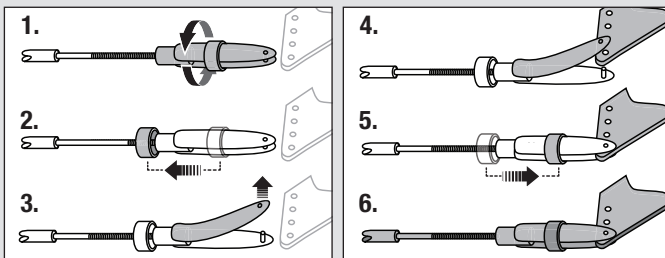

Control Surface Centering

After assembly and transmitter setup, confirm that the control surfaces are centered. If the control surfaces are not centered, mechanically center the control surfaces by adjusting the linkages.

If adjustment is required, turn the clevis on the linkage to change the length of the linkage between the servo arm and the control horn.

After binding a transmitter to the aircraft receiver, set the trims and sub-trims to 0, then adjust the clevises to center the control surfaces.

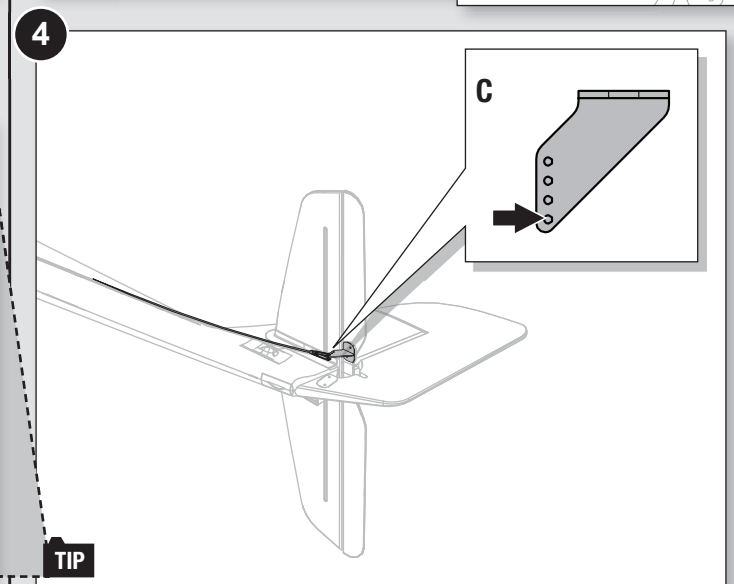
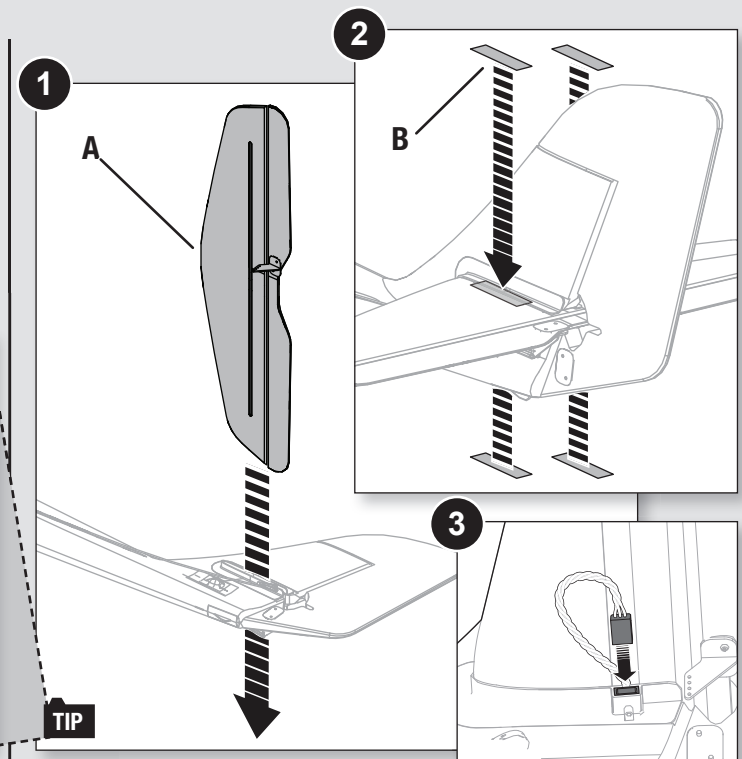
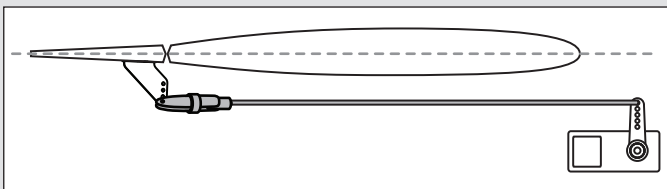

Model Assembly *Continued*

Wing Installation

1. Slide the wing tube (A) into the fuselage.
2. Install the left and right wing over the wing tube.
3. Guide the LED connectors (B) from both wings into the fuse and toward the bottom hatch.
4. Seat the wings in the slot of the fuselage. Be careful not to pinch any wires.
5. Secure the wings to the fuselage using the included 2 screws (C) as shown.
6. Connect the LED connectors to the connector block as shown. The LED connectors can be in any port of the block.

Disassemble in reverse order.

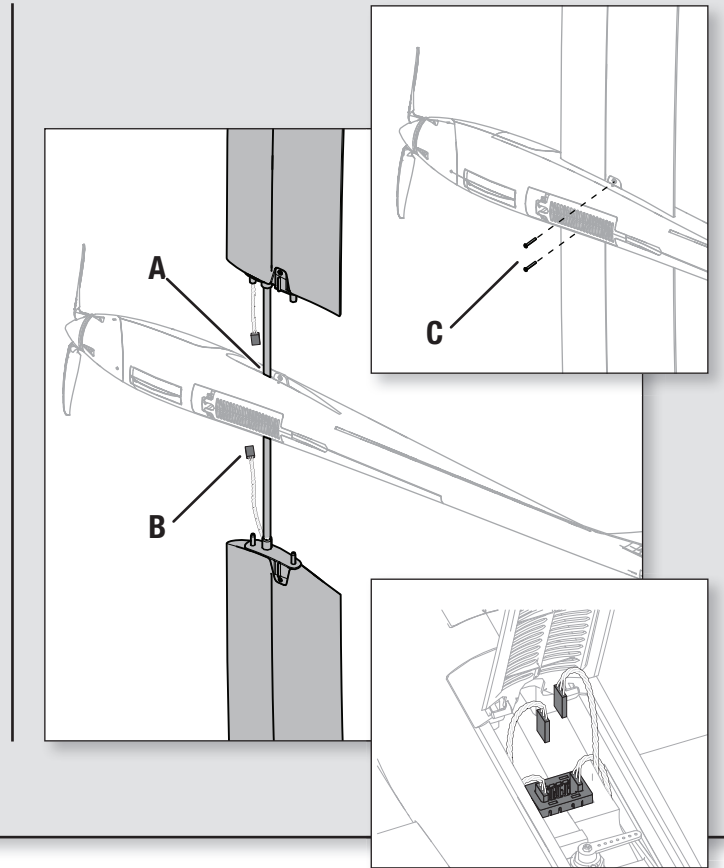

Control Horn and Servo Arm Settings

The table to the right shows the factory settings for the control horns and servo arms. Fly the aircraft at factory settings before making changes.

NOTICE: If control throws are changed from the factory settings, the AR636 gain values may need to be adjusted. Refer to the Spektrum AR636 manual for adjustment of gain values.

After flying, you may choose to adjust the linkage positions for the desired control response. See the table to the right.

Factory Setting	Horns	Arms
Elevator		
Rudder		

Tuning	Horns	Arms
More control throw		
Less control throw		

Transmitter and Receiver Binding / Switching ON and OFF SAFE Select

This product requires an approved Spektrum™ DSM2®/DSMX® compatible transmitter. Visit www.bindnfly.com for a complete list of approved transmitters.

The aircraft has an optional SAFE Select feature, which can be switched ON or OFF easily by binding in a specific manner as described below.

IMPORTANT: Before binding a transmitter, read the Transmitter Setup section of this manual to ensure that your transmitter is properly programmed for this aircraft.

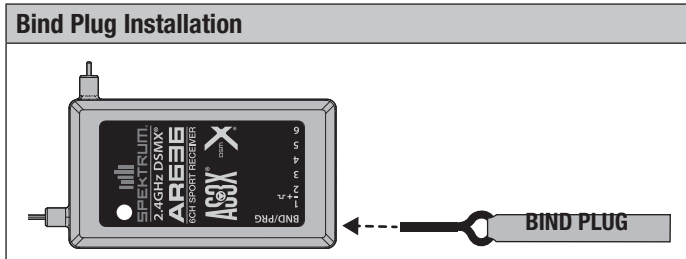

Binding Procedure / Switching ON SAFE Select

IMPORTANT: The included AR636A receiver has been programmed for operation specifically for this aircraft. Refer to the receiver manual for correct setup if the receiver is replaced or is used in another aircraft.

CAUTION: When using a Futaba® transmitter with a Spektrum DSM module, you must reverse the throttle channel and rebind. Refer to your Spektrum module manual for binding and failsafe instructions. Refer to your Futaba transmitter manual for instructions on reversing the throttle channel.

Make sure the transmitter is powered off.

Move the transmitter controls to neutral (flight controls: rudder, elevators and ailerons) or to low positions (throttle, throttle trim).*

Install a bind plug in the receiver bind port.

Place the aircraft level on the ground, connect the flight battery to the ESC. The ESC will produce a series of sounds. 3 flat tones to indicate cell count, followed immediately by 1 tone confirming that the ESC is armed. The orange bind LED on the receiver will begin to flash rapidly.

Remove the bind plug from the bind port.

Take 3 steps away from the aircraft /receiver and then power ON the transmitter while holding the transmitter bind button or switch. Refer to your transmitter's manual for specific binding instructions.

IMPORTANT: Do not to point the transmitter's antenna directly at the receiver while binding.

IMPORTANT: Keep away from large metal objects while binding.

The receiver is bound to the transmitter when the orange bind light on the receiver stays orange. The ESC will produce a series of sounds. 3 flat tones followed immediately by 2 ascending tones. The tones indicate the ESC is armed, provided the throttle stick and throttle trim are low enough to trigger arming.

IMPORTANT: Once bound, the receiver will retain its bind and last setting until it has been intentionally changed, even when power is cycled ON and OFF. However, if you notice that bind has been lost, simply repeat the binding process.

SAFE Select ON Indication

Every time the receiver is powered ON the surfaces will cycle back and forth **twice** with a slight pause at neutral position to indicate that SAFE Select is switched ON.

The throttle will not arm if the transmitter's throttle control is not put at the lowest position. If you encounter problems, follow the binding instructions and refer to the transmitter troubleshooting guide for other instructions. If needed, contact the appropriate Horizon Product Support office.

Switching ON SAFE Select Binding Sequence

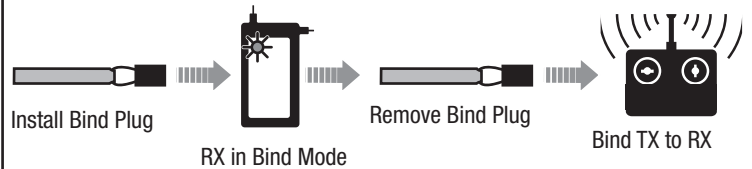

Switching OFF SAFE Select Binding Sequence

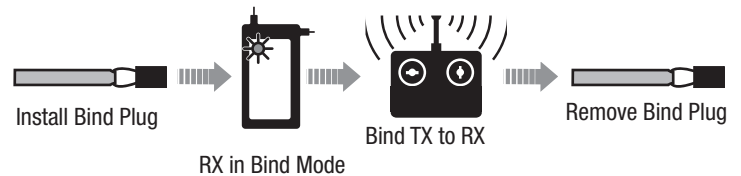

Binding Procedure / Switching OFF SAFE Select

IMPORTANT: The included AR636A receiver has been programmed for operation specifically for this aircraft. Refer to the receiver manual for correct setup if the receiver is replaced or is used in another aircraft.

CAUTION: When using a Futaba® transmitter with a Spektrum DSM module, you must reverse the throttle channel and rebind. Refer to your Spektrum module manual for binding and failsafe instructions. Refer to your Futaba transmitter manual for instructions on reversing the throttle channel.

Make sure the transmitter is powered off.

Move the transmitter controls to neutral (flight controls: rudder, elevators and ailerons) or to low positions (throttle, throttle trim).*

Install a bind plug in the receiver bind port.

Place the aircraft level on the ground, connect the flight battery to the ESC. The ESC will produce a series of sounds. 3 flat tones to indicate cell count, followed immediately by 1 tone confirming that the ESC is armed. The orange bind LED on the receiver will begin to flash rapidly.

The orange bind LED on the receiver will begin to flash rapidly. DO NOT remove the bind plug at this time.

Take 3 steps away from the aircraft /receiver and then power ON the transmitter while holding the transmitter bind button or switch. Refer to your transmitter's manual for specific binding instructions.

IMPORTANT: Do not to point the transmitter's antenna directly at the receiver while binding.

IMPORTANT: Keep away from large metal objects while binding.

The receiver is bound to the transmitter when the orange bind light on the receiver stays orange. The ESC will produce a series of sounds. 3 flat tones followed immediately by 2 ascending tones. The tones indicate the ESC is armed, provided the throttle stick and throttle trim are low enough to trigger arming.

Remove the bind plug from the bind port.

IMPORTANT: Once bound, the receiver will retain its bind and last setting until it has been intentionally changed, even when power is cycled ON and OFF. However, if you notice that bind has been lost, simply repeat the binding process.

SAFE Select OFF Indication

Every time the receiver is powered ON the surfaces will cycle back and forth **once** to indicate that SAFE Select has been switched OFF.

The throttle will not arm if the transmitter's throttle control is not put at the lowest position. If you encounter problems, follow the binding instructions and refer to the transmitter troubleshooting guide for other instructions. If needed, contact the appropriate Horizon Product Support office.

*Failsafe

If the receiver loses transmitter communication, the failsafe will activate. When activated, failsafe moves the throttle channel to its preset failsafe position (low throttle) that was set during binding. All other channels move to actively level the aircraft in flight.

SAFE® Select Switch Designation

SAFE® Select technology can be easily assigned to any open switch (2 or 3 position) on your transmitter. With this new feature, you now have the flexibility to enable or disable the technology while in flight.

IMPORTANT: Before assigning your desired switch, ensure that the travel for that channel is set at 100% in both directions.

Assigning a switch

Bind the aircraft correctly to activate SAFE Select. This will allow the system to be assigned to a switch.

Hold both transmitter sticks to the inside bottom corners and toggle the desired switch 5 times (1 toggle = full up and down) to assign that switch. The control surfaces of the aircraft will move, indicating the switch has been selected.

Repeat the process to assign a different switch if desired.

NOTICE: SAFE Select is assignable on any unused Channels 5–9.

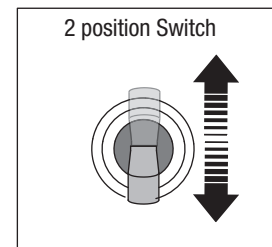
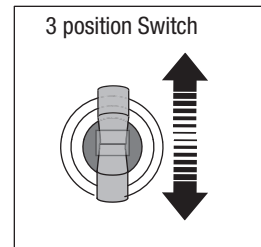
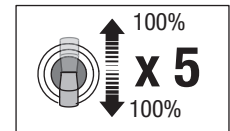
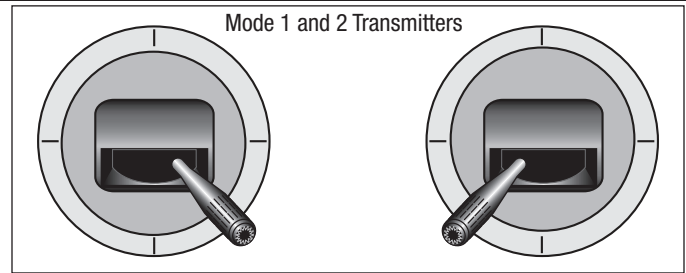

LED Controller

The LED controller (A) offers the ability to change the light pattern and speed as well as turn the lights on and off with the attached on/off switch (B).

1. Button 1 moves backward in the LED pattern list.
2. Button 2 cycles through the 7 speed settings
3. Button 3 moves forward in the LED pattern list.
4. Turn lights on or off with the attached On/Off switch.

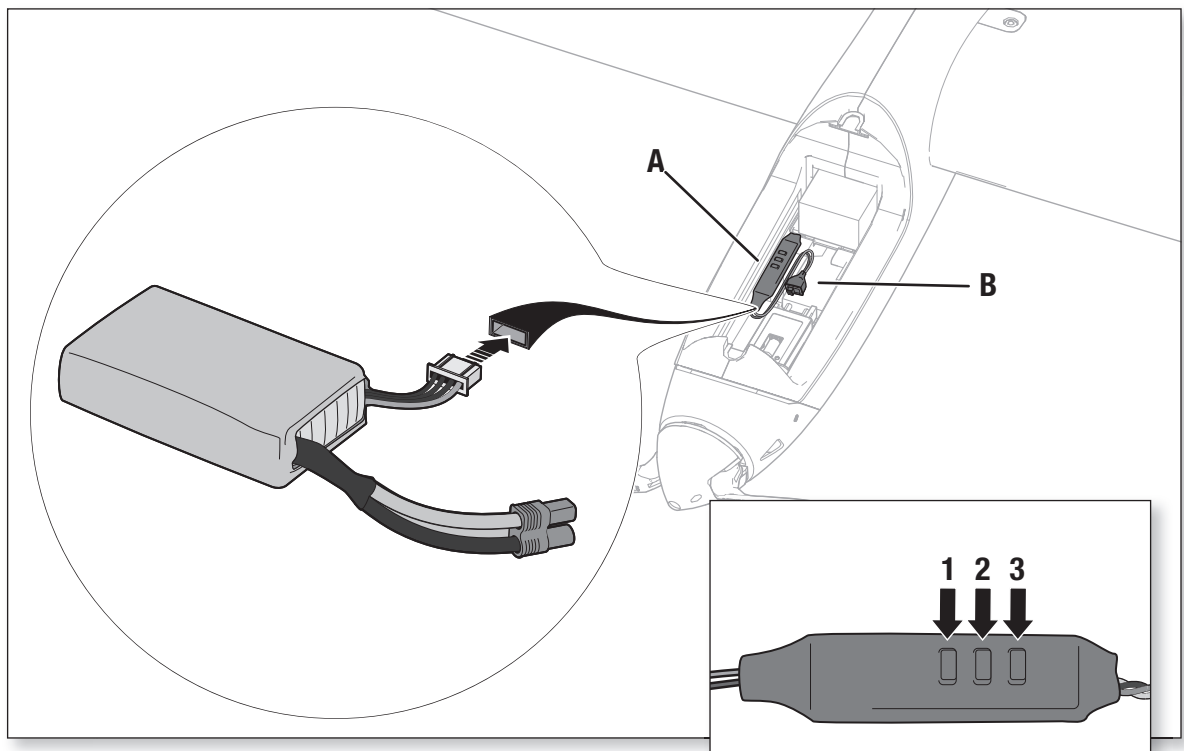

Battery Installation and ESC Arming

Battery Selection

We recommend the E-flite® 1350mAh 11.1V 30C Li-Po Battery (EFLB13503S30). Refer to the Optional Parts List for other recommended batteries. If using a battery other than those listed, the battery should be within the range of capacity, dimensions and weight of the E-flite Li-Po battery packs to fit in the fuselage. Be sure the model balances at the recommended CG.

1. Lower the throttle and throttle trim to the lowest settings. Power on the Transmitter, then wait 5 seconds.
2. Carefully lift the canopy hatch (B) to remove.
3. Install a fully charged battery (C) and secure it into place using the hook and loop strap (D). See the *Adjusting the Center of Gravity* instructions for more information.
4. Connect the battery to the ESC (the ESC is now armed).
 - The ESC will sound a series of tones (refer to step 6 of the binding instructions for more information).
 - An LED will light on the receiver.

If the ESC sounds a continuous double beep after the flight battery is connected, recharge or replace the battery.

5. Reinstall the canopy hatch.

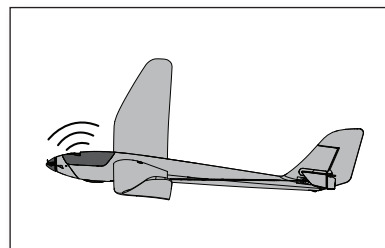
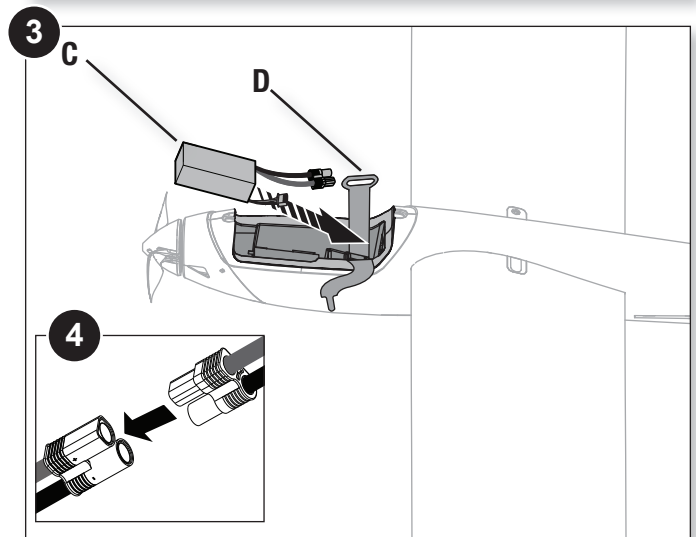
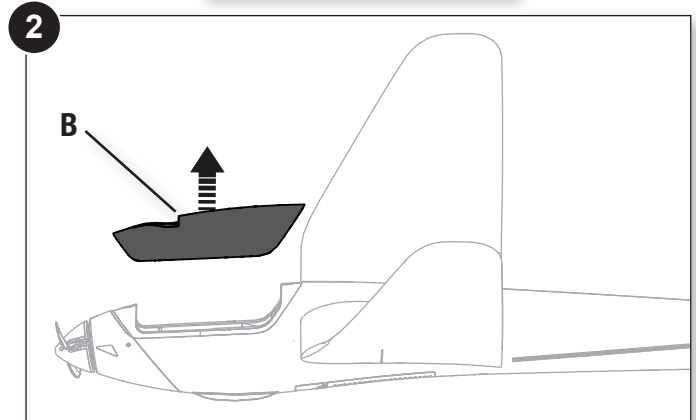
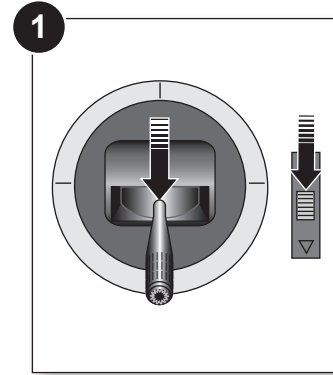

CAUTION: Always keep hands away from the propeller. When armed, the motor will turn the propeller in response to any throttle movement.

Center of Gravity (CG)

The CG location is measured from the leading edge of the wing at the root. This CG location has been determined with the recommended Li-Po battery (EFLB13003S20) installed all the way forward in the battery compartment.

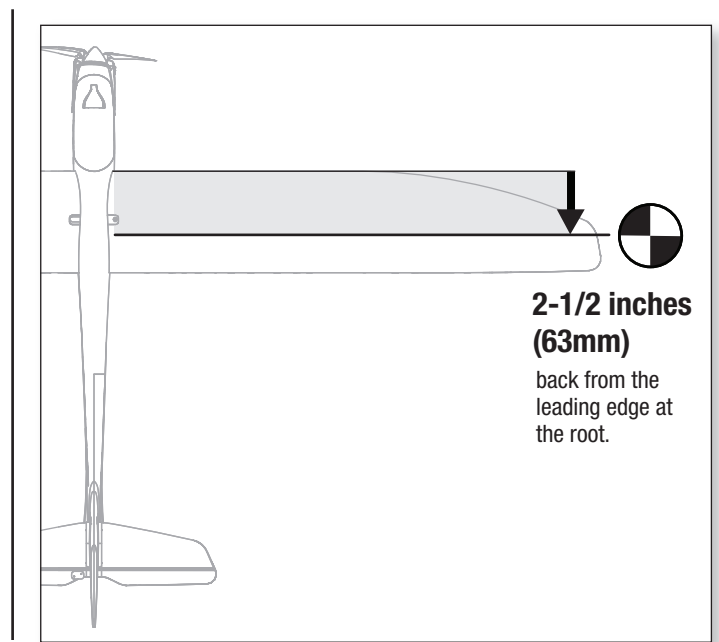

AS3X Control Direction Test

This test ensures that the AS3X® control system is functioning properly. Assemble the aircraft and bind your transmitter to the receiver before performing this test.

1. Raise the throttle just above 25%, then lower the throttle to activate AS3X technology.



CAUTION: Keep all body parts, hair and loose clothing away from a moving propeller, as these items could become entangled.

2. Move the entire aircraft as shown and ensure the control surfaces move in the direction indicated in the graphic. If the control surfaces do not respond as shown, do not fly the aircraft. Refer to the receiver manual for more information.

Once the AS3X system is active, control surfaces may move rapidly. This is normal. AS3X remains active until the battery is disconnected.

	Aircraft movement	AS3X Reaction
Elevator		
Rudder		

In Flight Trimming

During your first flight, trim the aircraft for level flight at 3/4 throttle with flaps and gear up. Make small trim adjustments with your transmitter's trim switches to straighten the aircraft's flight path.

After adjusting trim, do not touch the control sticks for 3 seconds. This allows the receiver to learn the correct settings to optimize AS3X performance.

Failure to do so could affect flight performance.

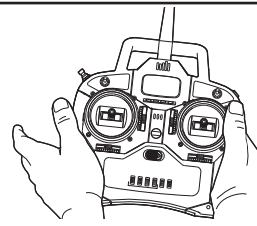

3 Seconds

Flying Tips and Repairs

Consult local laws and ordinances before choosing a flying location.

Range Check your Radio System

Before you fly, range check the radio system. Refer to your specific transmitter instruction manual for range test information.

Hand Launch

Set your dual rate switches to low rate. Hold the aircraft fuselage under the wing and gradually increase the throttle to 3/4. Launch the aircraft into the wind with the wings level. Allow the aircraft to climb to a comfortable altitude.

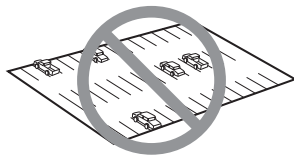

Flying

Always choose a wide-open space for flying your aircraft. It is recommended that you fly at a designated RC flying field. Always avoid flying near houses, trees, wires and buildings. Avoid flying in areas where there are many people, such as parks, schoolyards, or soccer fields.

Oscillation

Once the AS3X system is active (after advancing the throttle for the first time), you will normally see the control surfaces react to aircraft movement. In some flight conditions you may see oscillation (the aircraft rocks back and forth on one axis due to overcontrol). If oscillation occurs, refer to the Troubleshooting Guide for more information.

After landing, adjust the linkages mechanically to account for trim changes and then reset the trims to neutral. Ensure the aircraft will fly straight and level with no trim or sub-trim.

Landing

For your first flights with the recommended battery pack (EFLB13503S30), set your transmitter timer or a stopwatch to 7 minutes. After 7 minutes, land the aircraft. Adjust your timer for longer or shorter flights once you have flown the model. **If at any time the motor pulses, land the aircraft immediately to recharge the flight battery.** See the Low Voltage Cutoff (LVC) section for more details on maximizing battery health and run time.

Make sure to land into the wind. Due to the high lifting efficiency of the sailplane design, landing requires a large landing area. While on your downwind leg, remember that the sailplane glides much better than other aircraft. You will need to setup for landing lower and with a more shallow descent than you may be used to. As you are on approach for landing, ensure that the model is descending slowly, but also not accelerating. Maintain this descent and speed, and, as the model nears the ground (approximately 6 inches (15 cm)), slowly apply a small amount of up elevator. Before the aircraft touches down, always fully decrease throttle to avoid damage to the propeller, motor, ESC or other components.

WARNING: Always decrease throttle at propeller strike.

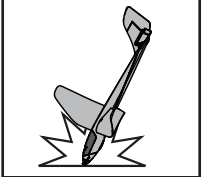

NOTICE: If a crash is imminent, reduce the throttle and trim fully. Failure to do so could result in extra damage to the airframe, as well as damage to the ESC and motor.

NOTICE: After any impact, always ensure the receiver is secure in the fuselage. If you replace the receiver, install the new receiver in the same orientation as the original receiver or damage may result.

NOTICE: Crash damage is not covered under warranty.

NOTICE: When you are finished flying, never leave the aircraft in direct sunlight or in a hot, enclosed area such as a car. Doing so can damage the aircraft.

Low Voltage Cutoff (LVC)

When a Li-Po battery is discharged below 3V per cell, it will not hold a charge. The ESC protects the flight battery from over-discharge using Low Voltage Cutoff (LVC). Before the battery charge decreases too much, LVC removes power supplied to the motor. Power to the motor pulses, showing that some battery power is reserved for flight control and safe landing.

Disconnect and remove the Li-Po battery from the aircraft after use to prevent trickle discharge. Charge your Li-Po battery to about half capacity before storage. During storage, make sure the battery charge does not fall below 3V per cell. LVC does not prevent the battery from over-discharge during storage.

NOTICE: Repeated flying to LVC will damage the battery.

Tip: Monitor your aircraft battery's voltage before and after flying by using a Li-Po Cell Voltage Checker (EFLA111, sold separately).

Repairs

Thanks to the Z-Foam™ material in this aircraft, repairs to the foam can be made using virtually any adhesive (hot glue, regular CA, epoxy, etc). **The horizontal tail is not made of the same material, so use only foam-compatible CA on the horizontal tail.**

When parts are not repairable, see the Replacement Parts List for ordering by item number. For a listing of all replacement and optional parts, refer to the list at the end of this manual.

NOTICE: Use of CA accelerant on your aircraft can damage paint. DO NOT handle the aircraft until accelerant fully dries.

Post Flight

1	Disconnect the flight battery from the ESC (Required for Safety and battery life).
2	Power OFF the transmitter.
3	Remove the flight battery from the aircraft.
4	Recharge the flight battery.

5	Repair or replace all damaged parts.
6	Store the flight battery apart from the aircraft and monitor the battery charge.
7	Make note of the flight conditions and flight plan results, planning for future flights.

Motor Service

CAUTION: Always disconnect the flight battery before performing motor service.

Disassembly

1. Remove the 2 screws (A) and spinner (B) from the spinner backplate (C).
2. Remove the propeller nut (D), backplate from the prop adapter (E). You will need a tool to loosen the spinner nut.
3. Push the propeller pins (F) from the spinner backplate to remove the propeller blades (G).
4. Remove the set screw (H) from the prop adapter and remove it from the motor shaft.
5. Remove the 3 cowl screws (J) from the motor mount/cowling (K) and remove it from the fuselage.
6. Remove the 4 screws (L) and motor (M) from the motor mount/cowling.
7. Disconnect the motor wires from the ESC wires.

Assembly

Assemble in reverse order.

- Correctly align and connect the motor wire colors with the ESC wires.
- The propeller size numbers (9.75x 7.5) must face forward toward the nose of the aircraft for correct propeller operation.
- A tool is required to tighten the lock nut on the collet.

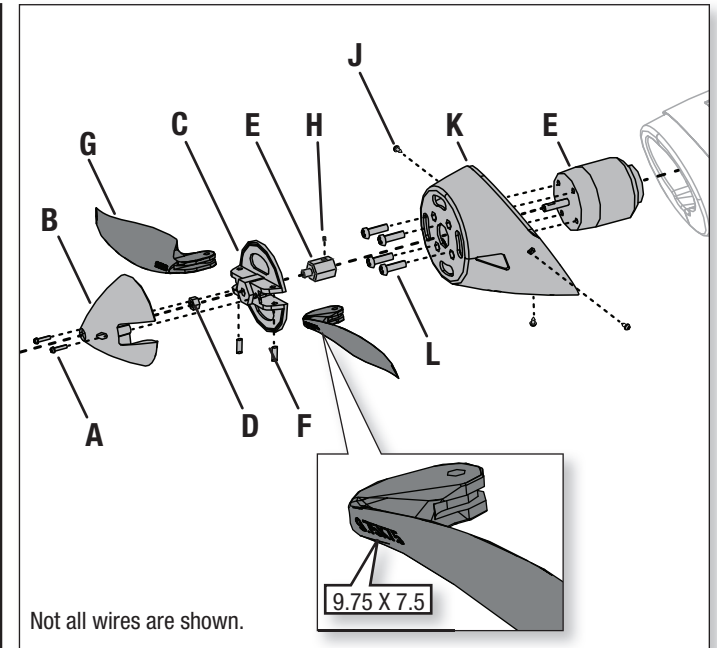

PNP Receiver Selection and Installation

The Spektrum AR636 receiver is recommended for this airplane. If you choose to install another receiver, ensure that it is at least a 6-channel full range (sport) receiver. Refer to your receiver manual for correct installation and operation instructions.

AR636 Port Assignments

BND/PRG = BIND	4 = NA
1 = Throttle	5 = Lights
2 = Rudder	6 = NA
3 = Elevator	

Installation

Remove the canopy from the fuselage.

Mount the receiver parallel to the length of the fuselage. Use double-sided servo tape.

Attach the appropriate control surfaces to their respective ports on the receiver using the chart in the illustration.



CAUTION: Incorrect installation of the receiver could cause a crash.

Troubleshooting Guide AS3X

Problem	Possible Cause	Solution
Oscillation	Damaged propeller or spinner	Replace propeller or spinner
	Imbalanced propeller	Balance the propeller. For more information, view the propeller balancing video at www.horizonhobby.com
	Motor vibration	Replace parts or correctly align all parts and tighten fasteners as needed
	Loose receiver	Align and secure receiver in fuselage
	Loose aircraft controls	Tighten or otherwise secure parts (servo, arm, linkage, horn and control surface)
	Worn parts	Replace worn parts (especially propeller, spinner or servo)
	Irregular servo movement	Replace servo
Inconsistent flight performance	Trim is not at neutral	If you adjust trim more than 8 clicks, adjust the clevis to remove trim
	Sub-Trim is not at neutral	No Sub-Trim is allowed. Adjust the servo linkage
	Aircraft was not kept immobile for 5 seconds after battery connection	With the throttle stick in lowest position. Disconnect battery, then reconnect battery and keep the aircraft still for 5 seconds
Incorrect response to the AS3X Control Direction Test	Incorrect direction settings in the receiver, which can cause a crash	DO NOT fly. Correct the direction settings (refer to the receiver manual), then fly

Troubleshooting Guide

Problem	Possible Cause	Solution
Aircraft will not respond to throttle but responds to other controls	Throttle not at idle and/or throttle trim too high	Reset controls with throttle stick and throttle trim at lowest setting
	Throttle servo travel is lower than 100%	Make sure throttle servo travel is 100% or greater
	Throttle channel is reversed	Reverse throttle channel on transmitter
	Motor disconnected from ESC	Make sure motor is connected to the ESC
Extra propeller noise or extra vibration	Damaged propeller and spinner, collet or motor	Replace damaged parts
	Propeller is out of balance	Balance or replace propeller
	Prop nut is too loose	Tighten the prop nut
	Spinner is not tight or fully seated in place	Inspect spinner to ensure it is fully seated
Reduced flight time or aircraft under-powered	Flight battery charge is low	Completely recharge flight battery
	Propeller installed backwards	Install propeller with numbers facing forward
	Flight battery damaged	Replace flight battery and follow flight battery instructions
	Flight conditions may be too cold	Make sure battery is warm before use
	Battery capacity too low for flight conditions	Replace battery or use a larger capacity battery
Aircraft will not Bind (during binding) to transmitter	Transmitter too near aircraft during binding process	Move powered transmitter a few feet from aircraft, disconnect and reconnect flight battery to aircraft
	Aircraft or transmitter is too close to large metal object, wireless source or another transmitter	Move aircraft and transmitter to another location and attempt binding again
	The bind plug is not installed correctly in the bind port	Install bind plug in bind port and bind the aircraft to the transmitter
	Flight battery/transmitter battery charge is too low	Replace/recharge batteries
	Bind switch or button not held long enough during bind process	Power off transmitter and repeat bind process. Hold transmitter bind button or switch until receiver is bound
Aircraft will not connect (after binding) to transmitter	Transmitter too near aircraft during connecting process	Move powered transmitter a few feet from aircraft, disconnect and reconnect flight battery to aircraft
	Aircraft or transmitter is too close to large metal object, wireless source or another transmitter	Move aircraft and transmitter to another location and attempt connecting again
	Bind plug left installed in bind port	Rebind transmitter to the aircraft and remove the bind plug before cycling power
	Aircraft bound to different model memory (ModelMatch™ radios only)	Select correct model memory on transmitter
	Flight battery/Transmitter battery charge is too low	Replace/recharge batteries
	Transmitter may have been bound to a different aircraft using different DSM protocol	Bind aircraft to transmitter
Control surface does not move	Control surface, control horn, linkage or servo damage	Replace or repair damaged parts and adjust controls
	Wire damaged or connections loose	Do a check of wires and connections, connect or replace as needed
	Transmitter is not bound correctly or the incorrect airplanes was selected	Re-bind or select correct airplanes in transmitter
	Flight battery charge is low	Fully recharge flight battery
	BEC (Battery Elimination Circuit) of the ESC is damaged	Replace ESC
Controls reversed	Transmitter settings are reversed	Perform the Control Direction Test and adjust the controls on transmitter appropriately
Motor power pulses then motor loses power	ESC uses default soft Low Voltage Cutoff (LVC)	Recharge flight battery or replace battery that is no longer performing
	Weather conditions might be too cold	Postpone flight until weather is warmer
	Battery is old, worn out, or damaged	Replace battery
	Battery C rating might be too small	Use recommended battery

AMA National Model Aircraft Safety Code

Effective January 1, 2014

A. GENERAL

A model aircraft is a non-human-carrying aircraft capable of sustained flight in the atmosphere. It may not exceed limitations of this code and is intended exclusively for sport, recreation, education and/or competition. All model flights must be conducted in accordance with this safety code and any additional rules specific to the flying site.

1. Model aircraft will not be flown:
 - (a) In a careless or reckless manner.
 - (b) At a location where model aircraft activities are prohibited.
2. Model aircraft pilots will:
 - (a) Yield the right of way to all man carrying aircraft.
 - (b) See and avoid all aircraft and a spotter must be used when appropriate. (AMA Document #540-D.)
 - (c) Not fly higher than approximately 400 feet above ground level within three (3) miles of an airport, without notifying the airport operator.
 - (d) Not interfere with operations and traffic patterns at any airport, heliport or seaplane base except where there is a mixed use agreement.
 - (e) Not exceed a takeoff weight, including fuel, of 55 pounds unless in compliance with the AMA Large Model Aircraft program. (AMA Document 520-A.)
 - (f) Ensure the aircraft is identified with the name and address or AMA number of the owner on the inside or affixed to the outside of the model aircraft. (This does not apply to model aircraft flown indoors).
 - (g) Not operate aircraft with metal-blade propellers or with gaseous boosts except for helicopters operated under the provisions of AMA Document #555.
 - (h) Not operate model aircraft while under the influence of alcohol or while using any drug which could adversely affect the pilot's ability to safely control the model.
 - (i) Not operate model aircraft carrying pyrotechnic devices which explode or burn, or any device which propels a projectile or drops any object that creates a hazard to persons or property.

Exceptions:

 - Free Flight fuses or devices that burn producing smoke and are securely attached to the model aircraft during flight.
 - Rocket motors (using solid propellant) up to a G-series size may be used provided they remain attached to the model during flight. Model rockets may be flown in accordance with the National Model Rocketry Safety Code but may not be launched from model aircraft.
 - Officially designated AMA Air Show Teams (AST) are authorized to use devices and practices as defined within the Team AMA Program Document (AMA Document #718).
 - (j) Not operate a turbine-powered aircraft, unless in compliance with the AMA turbine regulations. (AMA Document #510-A).
3. Model aircraft will not be flown in AMA sanctioned events, air shows or model demonstrations unless:
 - (a) The aircraft, control system and pilot skills have successfully demonstrated all maneuvers intended or anticipated prior to the specific event.
 - (b) An inexperienced pilot is assisted by an experienced pilot.
4. When and where required by rule, helmets must be properly worn and fastened. They must be OSHA, DOT, ANSI, SNELL or NOCSAE approved or comply with comparable standards.

B. RADIO CONTROL

1. All pilots shall avoid flying directly over unprotected people, vessels, vehicles or structures and shall avoid endangerment of life and property of others.
2. A successful radio equipment ground-range check in accordance with manufacturer's recommendations will be completed before the first flight of a new or repaired model aircraft.
3. At all flying sites a safety line(s) must be established in front of which all flying takes place (AMA Document #706.)
 - (a) Only personnel associated with flying the model aircraft are allowed at or in front of the safety line.
 - (b) At air shows or demonstrations, a straight safety line must be established.
 - (c) An area away from the safety line must be maintained for spectators.
 - (d) Intentional flying behind the safety line is prohibited.
4. RC model aircraft must use the radio-control frequencies currently allowed by the Federal Communications Commission (FCC). Only individuals properly licensed by the FCC are authorized to operate equipment on Amateur Band frequencies.
5. RC model aircraft will not operate within three (3) miles of any pre-existing flying site without a frequency-management agreement (AMA Documents #922 and #923.)
6. With the exception of events flown under official AMA Competition Regulations, excluding takeoff and landing, no powered model may be flown outdoors closer than 25 feet to any individual, except for the pilot and the pilot's helper(s) located at the flight line.
7. Under no circumstances may a pilot or other person touch a model aircraft in flight while it is still under power, except to divert it from striking an individual.
8. RC night flying requires a lighting system providing the pilot with a clear view of the model's attitude and orientation at all times. Hand-held illumination systems are inadequate for night flying operations.
9. The pilot of a RC model aircraft shall:
 - (a) Maintain control during the entire flight, maintaining visual contact without enhancement other than by corrective lenses prescribed for the pilot.
 - (b) Fly using the assistance of a camera or First-Person View (FPV) only in accordance with the procedures outlined in AMA Document #550.
 - (c) Fly using the assistance of autopilot or stabilization system only in accordance with the procedures outlined in AMA Document #560.

Please see your local or regional modeling association's guidelines for proper, safe operation of your model aircraft.

Limited Warranty

What this Warranty Covers

Horizon Hobby, LLC, (Horizon) warrants to the original purchaser that the product purchased (the "Product") will be free from defects in materials and workmanship at the date of purchase.

What is Not Covered

This warranty is not transferable and does not cover (i) cosmetic damage, (ii) damage due to acts of God, accident, misuse, abuse, negligence, commercial use, or due to improper use, installation, operation or maintenance, (iii) modification of or to any part of the Product, (iv) attempted service by anyone other than a Horizon Hobby authorized service center, (v) Product not purchased from an authorized Horizon dealer, or (vi) Product not compliant with applicable technical regulations, or (vii) use that violates any applicable laws, rules, or regulations.

OTHER THAN THE EXPRESS WARRANTY ABOVE, HORIZON MAKES NO OTHER WARRANTY OR REPRESENTATION, AND HEREBY DISCLAIMS ANY AND ALL IMPLIED WARRANTIES, INCLUDING, WITHOUT LIMITATION, THE IMPLIED WARRANTIES OF NON-INFRINGEMENT, MERCHANTABILITY AND FITNESS FOR A PARTICULAR PURPOSE. THE PURCHASER ACKNOWLEDGES THAT THEY ALONE HAVE DETERMINED THAT THE PRODUCT WILL SUITABLY MEET THE REQUIREMENTS OF THE PURCHASER'S INTENDED USE.

Purchaser's Remedy

Horizon's sole obligation and purchaser's sole and exclusive remedy shall be that Horizon will, at its option, either (i) service, or (ii) replace, any Product determined by Horizon to be defective. Horizon reserves the right to inspect any and all Product(s) involved in a warranty claim. Service or replacement decisions are at the sole discretion of Horizon. Proof of purchase is required for all warranty claims. SERVICE OR REPLACEMENT AS PROVIDED UNDER THIS WARRANTY IS THE PURCHASER'S SOLE AND EXCLUSIVE REMEDY.

Limitation of Liability

HORIZON SHALL NOT BE LIABLE FOR SPECIAL, INDIRECT, INCIDENTAL OR CONSEQUENTIAL DAMAGES, LOSS OF PROFITS OR PRODUCTION OR COMMERCIAL LOSS IN ANY WAY, REGARDLESS OF WHETHER SUCH CLAIM IS BASED IN CONTRACT, WARRANTY, TORT, NEGLIGENCE, STRICT LIABILITY OR ANY OTHER THEORY OF LIABILITY, EVEN IF HORIZON HAS BEEN ADVISED OF THE POSSIBILITY OF SUCH DAMAGES. Further, in no event shall the liability of Horizon exceed the individual price of the Product on which liability is asserted. As Horizon has no control over use, setup, final assembly, modification or misuse, no liability shall be assumed nor accepted for any resulting damage or injury. By the act of use, setup or assembly, the user accepts all resulting liability. If you as the purchaser or user are not prepared to accept the liability associated with the use of the Product, purchaser is advised to return the Product immediately in new and unused condition to the place of purchase.

Law

These terms are governed by Illinois law (without regard to conflict of law principals). This warranty gives you specific legal rights, and you may also have other rights which vary from state to state. Horizon reserves the right to change or modify this warranty at any time without notice.

WARRANTY SERVICES

Questions, Assistance, and Services

Your local hobby store and/or place of purchase cannot provide warranty support or service. Once assembly, setup or use of the Product has been started, you must contact your local distributor or Horizon directly. This will enable Horizon to better answer your questions and service you in the event that you may need any assistance. For questions or assistance, please visit our website at www.horizonhobby.com, submit a Product Support Inquiry, or call the toll free telephone number referenced in the Warranty and Service Contact Information section to speak with a Product Support representative.

Inspection or Services

If this Product needs to be inspected or serviced and is compliant in the country you live and use the Product in, please use the Horizon Online Service Request submission process found on our website or call Horizon to obtain a Return Merchandise Authorization (RMA) number. Pack the Product securely using a shipping carton. Please note that original boxes may be included, but are not designed to withstand the rigors of shipping without additional

protection. Ship via a carrier that provides tracking and insurance for lost or damaged parcels, as Horizon is not responsible for merchandise until it arrives and is accepted at our facility. An Online Service Request is available at http://www.horizonhobby.com/content/_service-center_render-service-center. If you do not have internet access, please contact Horizon Product Support to obtain a RMA number along with instructions for submitting your product for service. When calling Horizon, you will be asked to provide your complete name, street address, email address and phone number where you can be reached during business hours. When sending product into Horizon, please include your RMA number, a list of the included items, and a brief summary of the problem. A copy of your original sales receipt must be included for warranty consideration. Be sure your name, address, and RMA number are clearly written on the outside of the shipping carton.

NOTICE: Do not ship LiPo batteries to Horizon. If you have any issue with a LiPo battery, please contact the appropriate Horizon Product Support office.

Warranty Requirements

For Warranty consideration, you must include your original sales receipt verifying the proof-of-purchase date. Provided warranty conditions have been met, your Product will be serviced or replaced free of charge. Service or replacement decisions are at the sole discretion of Horizon.

Non-Warranty Service

Should your service not be covered by warranty, service will be completed and payment will be required without notification or estimate of the expense unless the expense exceeds 50% of the retail purchase cost. By submitting the item for service you are agreeing to payment of the service without notification. Service estimates are available upon request. You must include this request with your item submitted for service. Non-warranty service estimates will be billed a minimum of ½ hour of labor. In addition you will be billed for return freight. Horizon accepts money orders and cashier's checks, as well as Visa, MasterCard, American Express, and Discover cards. By submitting any item to Horizon for service, you are agreeing to Horizon's Terms and Conditions found on our website http://www.horizonhobby.com/content/_service-center_render-service-center.

ATTENTION: Horizon service is limited to Product compliant in the country of use and ownership. If received, a non-compliant Product will not be serviced. Further, the sender will be responsible for arranging return shipment of the un-serviced Product, through a carrier of the sender's choice and at the sender's expense. Horizon will hold non-compliant Product for a period of 60 days from notification, after which it will be discarded.

10/15

Contact Information

Country of Purchase	Horizon Hobby	Contact Information	Address
United States of America	Horizon Service Center (Repairs and Repair Requests)	servicecenter.horizonhobby.com/ RequestForm/	1608 Interstate Dr Champaign, Illinois, 61822 USA
	Horizon Product Support (Product Technical Assistance)	productsupport@horizonhobby.com 877-504-0233	
	Sales	websales@horizonhobby.com 800-338-4639	
European Union	Horizon Technischer Service	service@horizonhobby.eu	Hanskampring 9 D 22885 Barsbüttel, Germany
	Sales: Horizon Hobby GmbH	+49 (0) 4121 2655 100	

FCC Information

Supplier's Declaration of Conformity

Night Radian BNF Basic

Model Number: EFL3650

FC This device complies with part 15 of the FCC Rules. Operation is subject to the following two conditions: (1) This device may not cause harmful interference, and (2) this device must accept any interference received, including interference that may cause undesired operation.

CAUTION: Changes or modifications not expressly approved by the party responsible for compliance could void the user's authority to operate the equipment.

NOTE: This equipment has been tested and found to comply with the limits for a Class B digital device, pursuant to part 15 of the FCC Rules. These limits are designed to provide reasonable protection against harmful interference in a residential installation. This equipment generates, uses and can radiate radio frequency energy and, if not installed and used in accordance with the instructions, may cause harmful interference to radio communications. However, there

is no guarantee that interference will not occur in a particular installation. If this equipment does cause harmful interference to radio or television reception, which can be determined by turning the equipment off and on, the user is encouraged to try to correct the interference by one or more of the following measures:

- Reorient or relocate the receiving antenna.
- Increase the separation between the equipment and receiver.
- Connect the equipment into an outlet on a circuit different from that to which the receiver is connected.
- Consult the dealer or an experienced radio/TV technician for help.

Horizon Hobby, LLC
4105 Fieldstone Rd.,
Champaign, IL 61822
Email: compliance@horizonhobby.com

IC Information

This device complies with Industry Canada licence-exempt RSS standard(s).

Operation is subject to the following two conditions: (1) this device may not cause interference, and (2) this device must accept any interference, including interference that may cause undesired operation of the device."

Compliance Information for the European Union

EU Compliance Statement:

CE EFL3650 Eflite Night Radian FT 2.0m BNF-
Horizon Hobby, LLC hereby declares that this product is in compliance with the essential requirements and other relevant provisions of the RED and EMC Directives.

A copy of the EU Declaration of Conformity is available online at:
<http://www.horizonhobby.com/content/support-render-compliance>.

EU Compliance Statement:

CE EFL3675 Eflite Night Radian FT 2.0m PNP- Horizon Hobby, LLC hereby declares that this product is in compliance with the essential requirements and other relevant provisions of the EMC Directives.

A copy of the EU Declaration of Conformity is available online at:
<http://www.horizonhobby.com/content/support-render-compliance>.



Instructions for disposal of WEEE by users in the European Union

This product must not be disposed of with other waste. Instead, it is the user's responsibility to dispose of their waste equipment by handing it over to a designated collection point for the recycling of waste electrical and electronic equipment. The separate collection and recycling of your waste equipment at the time of disposal will help to conserve natural resources and make sure

that it is recycled in a manner that protects human health and the environment. For more information about where you can drop off your waste equipment for recycling, please contact your local city office, your household waste disposal service or where you purchased the product.



Replacement Parts • Ersatzteile • Pièces de rechange • Pezzi di ricambio

Part # Nummer Numéro Codice	Description	Beschreibung	Description	Descrizione
EPKZ1017	Propeller Blades	Propeller: Radian	Radian - Pales	Eliche: Radian
PKZ1018	Prop Adapter & Spinner Set	Luftschraubenmitnehmer und Spinner: Radian	Radian - Set adaptateur d'hélice & cône	Set adattatore elica & ogiva: Radian
PKZ1060	Mini Servo (3W) with Arms, Short Lead	Mini Servo, 3 adrig, kurzes Kabel	Mini Servo (3 fils) avec Palonniers, câble court	Servocomando mini (3W) con braccetti, cavo corto
PKZ4121	ControlHorns w/Hardware:3D/2	Steuerhorn mit Hardware: 3D/2	Renvois de commande avec matériel : 3D/2	Squadrette di controllo con elementi di fissaggio: 3D/2
PKZ4713	Canopy	Parkzone Kabinenhaube:Radian	Radian -Verrière	Parafiamma con viti: Radian
PKZ4714	Firewall w/Screws	Motorschott : Radian	Radian - Cloison Pare-feu avec Vis	Parafiamma con viti: Radian
PKZ4716	PKZ 480 Outrunner Brushless Motor:	Parkzone Radian BL Motor 480b	Radian - Moteur Brushless 480 à cage tournante	PKZ 480 motore outrunner brushless: Radian
PKZ5405	Wing Tube	Steckungsrohr	Tubes d'ailes	Tube ala
PKZ5422	Pushrods with Clevis	Parkzone Gestängeset: Radian Pro	Radian - Tringlerie avec chapes	Squadrette con forcelle: Radian
PKZ4725	Tail Wing Set	Parkzone Leitwerk : Radian	Radian - Empennages Horizontal	Set ali di coda: Radian
EFLA1030B	30-Amp Pro SB Brushless ESC	E-flite 30A Pro SB Regler	Contrôleur Brushless 30A Pro	30A Pro SB ESC brushless
EFL3651	Wing Set	Flügelsatz	Jeu d'ailes	Set ali
EFL3652	Fuse w/lights	Sicherung mit Beleuchtung	Fusible avec éclairages	Fusoliera con luci
EFL3653	Horizontal Stab	Höhenflosse	Stabilisateur horizontal	Stabilizzatore orizzontale
EFLA630	Light Set	Beleuchtungssatz	Ensemble d'éclairage	Set luci
EFL3655	Transparent Hatch	Transparente Abdeckugn	Trappe transparente	Coperchio trasparente

Optional Parts • Optionale Bauteile • Pièces optionnelles • Pezzi opzionali

Part # Nummer Numéro Codice	Description	Beschreibung	Description	Descrizione
EFLA250	Park Flyer Tool Assortment, 5 pc	Park Flyer Werkzeugsortiment, 5 teilig	Assortiment d'outils park flyer, 5pc	Park Flyer assortimento attrezzi, 5 pc
EFLAEC302	EC3 Battery Connector, Female (2)	EC3 Akkukabel, Buchse (2)	Prise EC3 femelle (2pc)	EC3 Connettore femmina x batteria (2)
EFLAEC303	EC3 Device/Battery Connector, Male/Female	EC3 Kabelsatz, Stecker/Buchse	Prise EC3 male/femelle	EC3 Connettore batteria maschio/femmina
EFLB13503S30	11.1V 3S 30C 1350mAh Li-Po	11.1V 3S 30C 1350mAh LiPo	11.1V 3S 30C 1350mAh Li-Po	11.1V 3S 30C 1350mAh Li-Po
DYNC2020A	Prophet Sport Duo 50W x 2 AC Battery Charger	Dynamite Prophet Sport Duo 50W x 2 AC Ladegerät, EU	Chargeur Prophet Sport Duo 50W x 2 AC	Prophet Sport Duo 50W x 2 AC caricabatteria
DYNC2010CA	Prophet Sport Plus 50W AC DC Charger	Dynamite Ladegerät Prophet Sport Plus 50W AC/DC EU	Chargeur Prophet Sport Plus 50W AC DC	Caricabatterie Prophet Sport Plus 50W AC DC
EFLA111	Li-Po Cell Voltage Checker	Li-Po Cell Voltage Checker	Testeur de tension d'éléments Li-Po	Voltmetro verifica batterie LiPo
DYN1405	Li-Po Charge Protection Bag, Large	Dynamite LiPoCharge Protection Bag groß	Sac de charge Li-Po, grand modèle.	Sacchetto grande di protezione per carica LiPo
DYN1400	Li-Po Charge Protection Bag, Small	Dynamite LiPoCharge Protection Bag klein	Sac de charge Li-Po, petit modèle	Sacchetto piccolo di protezione per carica LiPo
	DXe DSMX 6-Channel Transmitter	Spektrum DXe DSMX 6-Kanal Sender	Emetteur DXe DSMX 6 voies	DXe DSMX Trasmettitore 6 canali
	DX6eDSMX 6-Channel Transmitter	Spektrum DX6e DSMX 6-Kanal Sender	Emetteur DX6e DSMX 6 voies	DX6e DSMX Trasmettitore 6 canali
	DX6 DSMX 6-Channel Transmitter	Spektrum DX6 DSMX 6-Kanal Sender	Emetteur DX6 DSMX 6 voies	DX6 DSMX Trasmettitore 6 canali
	DX7G2 DSMX 7-Channel Transmitter	Spektrum DX7 DSMX 7 Kanal Sender	Emetteur DX7 DSMX 7 voies	DX7 DSMX Trasmettitore 7 canali
	DX8G2 DSMX 8-Channel Transmitter	Spektrum DX8G2 DSMX 8 Kanal Sender	Emetteur DX8G2 DSMX 8 voies	DX8G2 DSMX Trasmettitore 8 canali
	DX9 DSMX 9-Channel Transmitter	Spektrum DX9 DSMX 9 Kanal Sender	Emetteur DX9 DSMX 9 voies	DX9 DSMX Trasmettitore 9 canali
	DX18 DSMX 18-Channel Transmitter	Spektrum DX18 DSMX 18 Kanal Sender	Emetteur DX18 DSMX 18 voies	DX18 DSMX Trasmettitore 18 canali
	DX20 DSMX 20-Channel Transmitter	Spektrum DX20 DSMX 20 Kanal Sender	Emetteur DX20 DSMX 20 voies	DX20 DSMX Trasmettitore 20 canali
	iX12 DSMX 12-Channel Transmitter	Spektrum iX12 DSMX 12 Kanal Sender	Emetteur iX12 DSMX 12 voies	iX12 DSMX Trasmettitore 12 canali

Recommended Receivers • Empfohlene Empfänger

Récepteurs Recommandés • Ricevitori Raccomandati

PNP Only • Nur PNP • PNP Uniquement • Solo PNP

Part # Nummer Numéro Codice	Description	Beschreibung	Description	Descrizione
SPMAR610	AR610 6-Channel Coated Air Receiver	Ummantelter AR610-6-Kanal-Flugzeugempfänger	Récepteur aérien avec revêtement 6 canaux AR610	Ricevente aereo AR610 6 canali con rivestimento
	Telemetry Equipped Receivers	Empfänger mit Telemetrie	Récepteurs avec télémétrie	Riceventi con telemetria
SPMAR6600T	AR6600T 6-Channel Air Integrated Telemetry Receiver	AR6600T-6-Kanal-Flugzeugempfänger mit integrierter Telemetrie	Récepteur aérien avec télémétrie intégrée 6 canaux AR6600T	Ricevente aereo AR6600T 6 canali con telemetria integrata
SPMAR6270T	AR6270T 6-Channel Carbon Fuse Integrated Telemetry Receiver	AR6270T-6-Kanal-Karbon-Sicherungsempfänger mit integrierter Telemetrie	Récepteur à fusibles en carbone avec télémétrie intégrée 6 canaux AR6270T	Ricevente AR6270T 6 canali con telemetria integrata per fusoliera in carbonio
SPMAR8010T	AR8010T 8-Channel Air Integrated Telemetry Receiver	AR8010T-8-Kanal-Flugzeugempfänger mit integrierter Telemetrie	Récepteur aérien avec télémétrie intégrée 8 canaux AR8010T	Ricevente aereo AR8010T 8 canali con telemetria integrata
SPMAR9030T	AR9030T 9-Channel Air Integrated Telemetry Receiver	AR9030T-9-Kanal-Flugzeugempfänger mit integrierter Telemetrie	Récepteur aérien avec télémétrie intégrée 9 canaux AR9030T	Ricevente aereo AR9030T 9 canali con telemetria integrata
	AS3X Equipped Receivers	AS3X-Empfänger	Récepteurs avec AS3X	Riceventi con AS3X
SPMAR636	AR636 6-Channel AS3X Sport Receiver	AR636-6-Kanal-AS3X-Sportempfänger	Récepteur AS3X sport 6 canaux AR636	AR636 ricevitore sportivo a 6 canali AS3X
	AS3X and Telemetry Equipped Receivers	AS3X- und Telemetrieempfänger	Récepteurs avec AS3X et télémétrie	Riceventi con AS3X e telemetria
SPMAR7350	AR7350 7-Channel AS3X Receiver with Integrated Telemetry	AR7350-7-Kanal-Empfänger	Récepteur 7 canaux AR7350	Ricevente AR7350 7 canali
SPMAR9350	AR9350 7-Channel AS3X Receiver with Integrated Telemetry	AR9350-7-Kanal-Empfänger	Récepteur 7 canaux AR9350	Ricevente AR9350 7 canali
	Telemetry Sensors*	Telemetriesensoren*	Capteurs télémétriques*	Sensori di telemetria*
SPMA9574	Aircraft Telemetry Airspeed Indicator	Flugzeugtelemetrie-Luftgeschwindigkeitsanzeige	Indicateur télémétrique de vitesse aérodynamique pour avion	Telemetria per aerei - Anemometro
SPMA9589	Aircraft Telemetry Altitude and Variometer Sensor	Flugzeugtelemetrie-Höhen- und Variometer-Sensor	Indicateur télémétrique d'altitude et variomètre pour avion	Telemetria per aerei - Sensore altimetrico e variometro
SPMA9558	Brushless RPM Sensor	Bürstenloser Drehzahlsensor	Capteur de tr/min sans balai	Sensore RPM brushless
SPMA9605	Aircraft Telemetry Flight Pack Battery Energy Sensor	Flugzeugtelemetrie-Flugakku-pack-Energiesensor	Capteur télémétrique de niveau de batterie de vol pour avion	Telemetria per aerei - Sensore per la misura dell'energia della batteria di bordo
SPMA9587	Aircraft Telemetry GPS Sensor	Flugzeugtelemetrie-GPS-Sensor	Capteur télémétrique GPS pour avion	Telemetria per aerei - Sensore GPS

*Not compatible with BNF, Telemetry receiver required

*Nicht kompatibel mit BNF, Telemetrieempfänger erforderlich

*Non compatible avec les modèles BNF, récepteur télémétrique requis

*Non compatibile con BNF, necessita di ricevente con telemetria



Night Radian® FT

© 2018 Horizon Hobby, LLC.

E-flite, DSM, DSM2, DSMX, the DSMX logo, Bind-N-Fly, Z-Foam, ModelMatch, EC3, Celectra and the Horizon Hobby logo are trademarks or registered trademarks of Horizon Hobby, LLC.

The Spektrum trademark is used with permission of Bachmann Industries, Inc.

Futaba is a registered trademark of Futaba Denshi Kogyo Kabushiki Kaisha Corporation of Japan.

All other trademarks, service marks and logos are property of their respective owners.

US 8,672,726.

<http://www.e-fliterc.com/>