

RECCOIL®

26-INCH SELF-RIGHTING DEEP-V BL RTR
PRB08022

Owners Manual • Bedienungsanleitung
Manuel de l'utilisateur • Manuale dell'utente

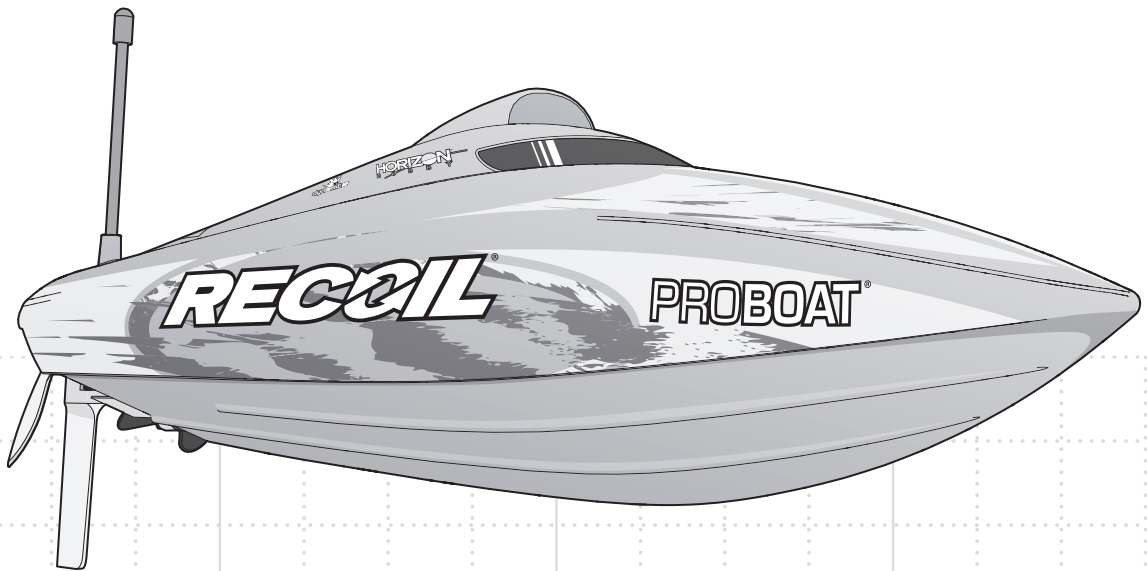

NOTICE

All instructions, warranties and other collateral documents are subject to change at the sole discretion of Horizon Hobby, LLC. For up-to-date product literature, visit <http://www.horizonhobby.com> and click on the support tab for this product.

MEANING OF SPECIAL LANGUAGE

The following terms are used throughout the product literature to indicate various levels of potential harm when operating this product:

NOTICE: Procedures, which if not properly followed, create a possibility of physical property damage AND little or no possibility of injury.

CAUTION: Procedures, which if not properly followed, create the probability of physical property damage AND a possibility of serious injury.

WARNING: Procedures, which if not properly followed, create the probability of property damage, collateral damage, and serious injury OR create a high probability of superficial injury.



WARNING: Read the ENTIRE instruction manual to become familiar with the features of the product before operating. Failure to operate the product correctly can result in damage to the product, personal property and cause serious injury.

This is a sophisticated hobby product and NOT a toy. It must be operated with caution and common sense and requires some basic mechanical ability. Failure to operate this Product in a safe and responsible manner could result in injury or damage to the product or other property. This product is not intended for use by children without direct adult supervision. Do not use with incompatible components or alter this product in any way outside of the instructions provided by Horizon Hobby, LLC. This manual contains instructions for safety, operation and maintenance. It is essential to read and follow all the instructions and warnings in the manual, prior to assembly, setup or use, in order to operate correctly and avoid damage or serious injury.

Age Recommendation: Not for children under 14 years. This is not a toy.

Safety Precautions and Warnings

As the user of this product, you are solely responsible for operating in a manner that does not endanger yourself and others or result in damage to the product or the property of others.

- When handling and/or transporting your boat, always pick up the boat from the front, keeping all moving parts pointed away from you.
- Always keep a safe distance in all directions around your model to avoid collisions or injury. This model is controlled by a radio signal subject to interference from many sources outside your control. Interference can cause momentary loss of control.
- Always operate your model in open spaces away from full-size vehicles, traffic and people.
- Always carefully follow the directions and warnings for this and any optional support equipment (chargers, rechargeable battery packs, etc.).
- Always keep all chemicals, small parts and anything electrical out of the reach of children.
- Always avoid water exposure to all equipment not specifically designed and protected for this purpose. Moisture causes damage to unprotected electronics.
- Never place any portion of the model in your mouth as it could cause serious injury or even death.
- Never operate your model with low transmitter batteries.

Charging Warnings

The included Battery Charger is designed to safely balance and charge the Li-Po battery.



CAUTION: All instructions and warnings must be followed exactly. Mishandling of Li-Po batteries can result in a fire, personal injury, and/or property damage.

- **NEVER LEAVE CHARGING BATTERIES UNATTENDED.**
- **NEVER CHARGE BATTERIES OVERNIGHT.**
- By handling, charging or using the included Li-Po battery, you assume all risks associated with lithium batteries.
- If at any time the battery begins to balloon or swell, discontinue use immediately. If charging or discharging, discontinue and disconnect. Continuing to use, charge or discharge a battery that is ballooning or swelling can result in fire.
- Always store the battery at room temperature in a dry area for best results.
- Always transport or temporarily store the battery in a temperature range of 40–120° F (5–49° C). Do not store battery or aircraft in a car or direct sunlight. If stored in a hot car, the battery can be damaged or even catch fire.
- Always charge batteries away from flammable materials.
- Always inspect the battery before charging and never charge damaged batteries.
- Always disconnect the battery after charging, and let the charger cool between charges.
- Always constantly monitor the temperature of the battery pack while charging.
- **ONLY USE A CHARGER SPECIFICALLY DESIGNED TO CHARGE LI-PO BATTERIES.**
- Failure to charge the battery with a compatible charger may cause fire resulting in personal injury and/or property damage.
- Never discharge Li-Po cells to below 3V under load.
- Never cover warning labels with hook and loop strips.
- Never charge batteries outside recommended levels.
- Never attempt to dismantle or alter the charger.
- Never allow minors to charge battery packs.
- Never charge batteries in extremely hot or cold places (recommended between 40–120° F or 5–49° C) or place in direct sunlight.

Recommended Tools and Materials

- Paper towel
- Rubbing alcohol
- Open-end wrench: 10mm (1), 12mm (1)
- Nut driver: 5.5mm, 7mm
- Hex wrench: 2mm, 2.5mm
- Clear tape (DYNM0102)
- Dynamite® Marine Grease and Gun (DYNE4200)
- Hook and Loop Tape Set, WP 4pcs (DYNK0300)
- Clean towels

Water-Resistant Boat with Waterproof Electronics

Your new Horizon Hobby boat has been designed and built with a combination of waterproof and water-resistant components to allow you to operate the product in calm, fresh water conditions.

While the entire boat is highly water-resistant, it is not completely waterproof and your boat should NOT be treated like a submarine. The various electronic components used in the boat, such as the ESC, servo(s) and receiver are waterproof, however, most of the mechanical components are water-resistant and require additional maintenance after use.

Metal parts, including the bearings, pins, screws and nuts, propeller, rudder, rudder mounts, prop struts, as well as

the contacts in the electrical cables, will be susceptible to corrosion if additional maintenance is not performed after running in wet conditions. To maximize the long-term performance of your boat and to keep the warranty intact, the procedures described in the **WET CONDITIONS MAINTENANCE** section must be performed regularly.

CAUTION: Failure to exercise caution while using this product and complying with the following precautions could result in product malfunction and/or void the warranty.

General Precautions

- Read the **WET CONDITIONS MAINTENANCE** procedures and make sure that you have all the tools you will need to properly maintain your boat.
- Not all batteries can be used in wet conditions. Consult the battery manufacturer before use. Caution should be taken when using Li-Po batteries in wet conditions.
- Most transmitters are not water-resistant. Consult your transmitter's manual or the manufacturer before operation.
- Never operate your transmitter or boat when lightning is present.
- Salt water is very conductive and highly corrosive. If you choose to run your boat in salt water, immediately rinse the boat in fresh water after each use. Operating your boat in salt water is at the sole discretion of the modeler.

Wet Conditions Maintenance

- Drain any water that has collected in the hull by removing the drain plug or canopy and tilting the boat in the appropriate direction to drain the water.

CAUTION: Always keep hands, fingers, tools and any loose or hanging objects away from rotating parts.

- Remove the battery pack(s) and dry the contacts. If you have an air compressor or a can of compressed air, blow out any water that may be inside the recessed connector housings.
- Remove all moving parts. Dry and lubricate parts after every 30 minutes of operation or if the boat becomes submerged.

NOTICE: Never use a pressure washer to clean your boat.

- Use an air compressor or a can of compressed air to dry the boat and help remove any water that may have gotten into small crevices or corners.
- Spray the bearings, fasteners and other metal parts with a water-displacing light oil or lubricant.
- Let the boat air dry before you store it. Water (and oil) may continue to drip for a few hours.

Table of Contents

Transmitter Controls.....	4
Installing Transmitter Batteries.....	4
Battery Charger.....	4
Low Voltage Cutoff.....	5
Battery Chemistry.....	5
Getting Started.....	5
Control Check.....	6
Boating Tips.....	6
Self-Righting.....	6
When You Are Finished.....	7
Maintenance.....	7
Drivetrain Lubrication.....	7
Propeller Service.....	8
Rudder Service.....	8
Rudder Trim.....	8
Water Cooling System.....	9
Binding.....	9
Transmitter Calibration.....	9
Failsafe.....	10
Transmitter Calibration.....	10
Transmitter Programming.....	10
Troubleshooting Guide.....	11
LIMITED WARRANTY.....	12
Contact Information.....	13
FCC Statement.....	13
IC Information.....	13
Compliance Information for the European Union.....	13
Replacement Parts.....	50
Optional Parts.....	51

Specifications

Length	26 in (660.4mm)
Beam (width)	7.9 in (200mm)
Hull Material	Blow-Molded ABS Plastic
Motor	Dynamite® Outrunner BL marine motor
ESC	Dynamite® 60-amp brushless, water-cooled
Transmitter	Spektrum™ STX2™ 2CH 2.4GHz FHSS
Receiver	Spektrum™ STX2™ 2CH 2.4GHz FHSS
Batteries	11.1V 3200mAh 3S 30C LiPo with EC3™ connector
	(4) AA batteries (sold separately) are required to operate the transmitter.

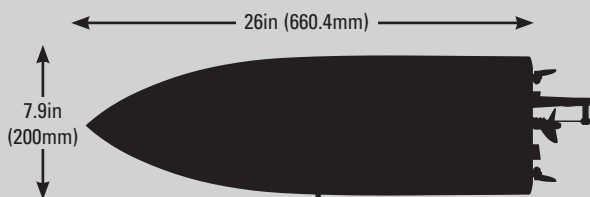

Transmitter Controls

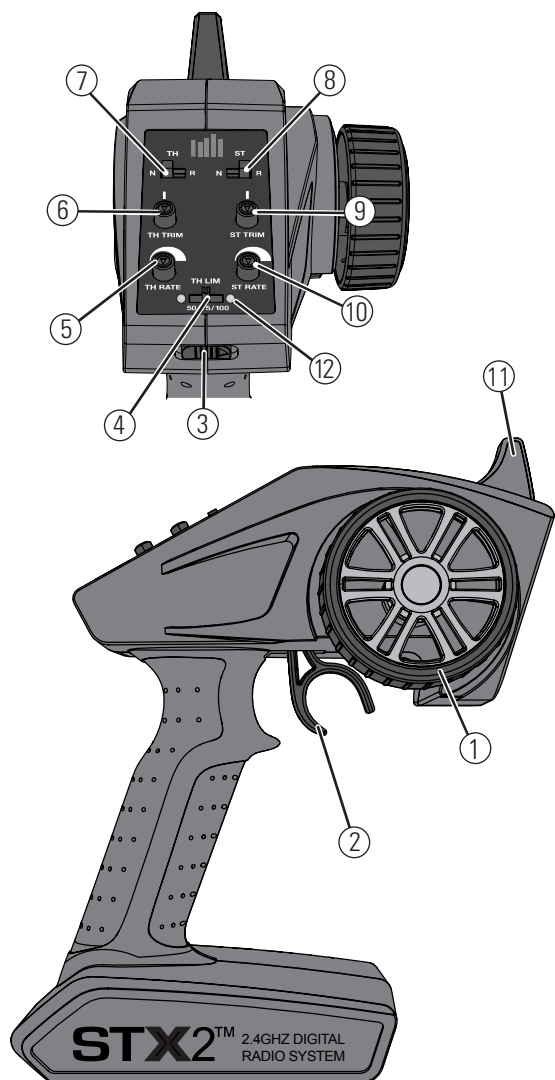

1. **Steering Wheel** Controls direction (left/right) of the model
2. **Throttle Trigger** Controls speed and direction (forward/brake/reverse) of the model
3. **ON/OFF Switch** Turns the power ON/OFF
4. **Throttle Limiting Switch** Adjusts the throttle limit from 50%, 75%, and 100%
5. **TH Rate** Adjusts the end point of the throttle
6. **TH Trim** Adjusts the throttle neutral point
7. **TH REV** Reverses the function of the speed control when pulled back or pushed forward
8. **ST REV** Reverses the function of the steering when the wheel is turned left or right
9. **ST Trim** Adjusts the steering center point
10. **ST Rate** Adjusts the end point of the steering
11. **Antenna** Transmits the signal to the model
12. **Indicator Lights**
 - **Solid red lights**—Indicates radio connectivity and adequate battery power
 - **Flashing red lights**—Indicates the battery voltage is critically low. Replace batteries

Installing Transmitter Batteries

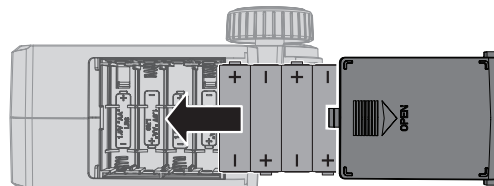

This transmitter requires 4 AA batteries.

1. Remove the battery cover from the transmitter.
2. Install the batteries as shown.
3. Install the battery cover.

CAUTION: If using rechargeable batteries, charge only rechargeable batteries. Charging non-rechargeable batteries may cause the batteries to burst, resulting in injury to persons and/or damage to property.

CAUTION: Risk of explosion if battery is replaced by an incorrect type. Dispose of used batteries according to national regulations.

Battery Charger

Refer to the Charging Warnings for additional instructions.

NOTICE: Never charge a battery in the boat or damage may result.

1. Connect the AC power cord to the power slot on the charger, then connect the other end of the power cord to an AC power source.
2. The three LEDs will turn GREEN when the charger is connected to the AC power source.
3. Connect the balance connector of the battery pack to the proper connector on the charger (the 3S connector has 4 pins and the 2S connector has 3 pins).
4. The three LEDs will turn RED, indicating the battery is charging.
5. When the charging of one cell is complete, the corresponding LED turns GREEN.

6. Once the battery pack is fully charged, all three LEDs will turn GREEN.
7. Disconnect the balance connector and battery from the charger.

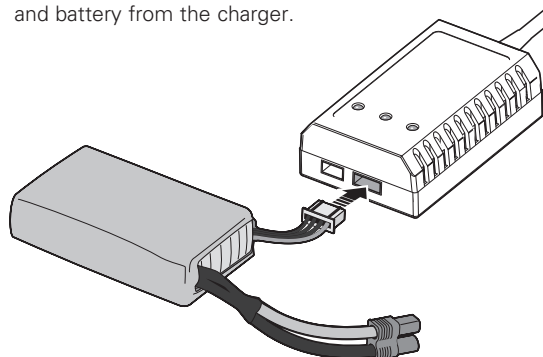

Low Voltage Cutoff (LVC)

Discharging a Li-Po battery below 3V per cell may damage your battery. The included ESC protects the boat battery from over-discharge using Low Voltage Cutoff (LVC). Before the battery charge decreases too much, LVC removes power supplied to the motor. Power to the motor pulses, showing that some battery power is reserved for boat control and safe landing.

Disconnect and remove the Li-Po battery from the boat after use to prevent trickle discharge. Charge your Li-Po battery to about half capacity before storage. During storage, make sure the battery charge does not fall below 3V per cell. LVC does not prevent the battery from over-discharge during storage.

NOTICE: Repeated operation to LVC will damage the battery.

Tip: Monitor your boat battery's voltage before and after boating by using a Li-Po Cell Voltage Checker (DYN4071, sold separately).

Battery Chemistry

The ESC comes from the factory in Li-Po Mode. To change battery chemistry:

1. Keep the throttle at neutral and power ON the ESC.
2. Press and hold the Battery Chemistry Button on the power switch for 3 seconds. The LED flashes the current battery chemistry (red = Ni-MH or Ni-Cd; green = Li-Po).
3. Continue holding the Battery Chemistry Button for another 6 seconds. The ESC changes battery chemistry and the LED flashes the new battery chemistry.
4. Power OFF the ESC. The ESC saves the setting until it is changed.

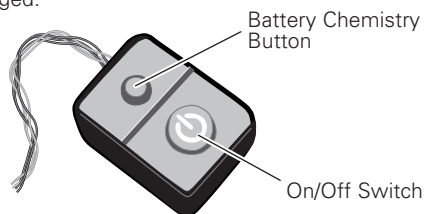

Getting Started

1. Install 4 AA batteries into the transmitter.
2. Remove the canopy from the hull.
3. Install the receiver antenna in the antenna tube.
4. Install the fully charged battery in the compartment and secure it with the hook and loop strap.
5. Power on the transmitter. Ensure the throttle is not reversed and the throttle trim is neutral.
6. Connect the battery to the ESC.
7. Keep the throttle at neutral and power ON the ESC. The ESC automatically calibrates the throttle range after 3

seconds. A beep will sound, indicating battery chemistry and cell count:

- 1 beep: Ni-MH or Ni-Cd
- 2 beeps: 2S Li-Po
- 3 beeps: 3S Li-Po

One short beep will sound when the ESC is ready to run.

8. Test the transmitter's control of the boat with the boat on the display stand.
9. Install the canopy on the hull.

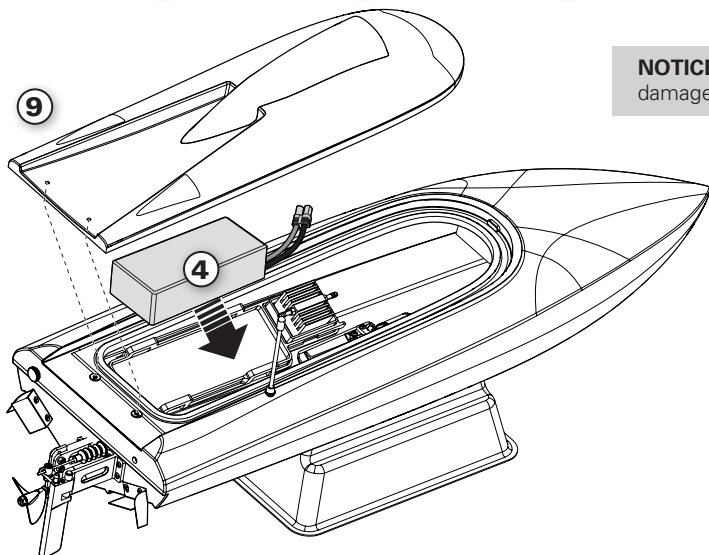
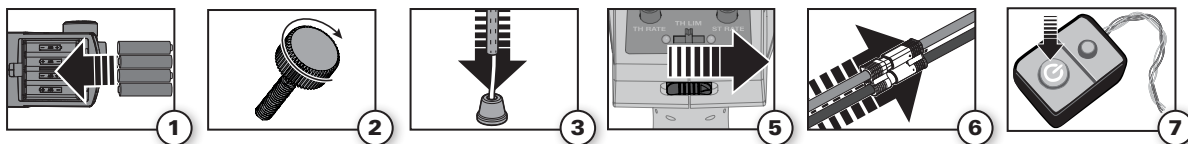

NOTICE: Do not cut or kink the receiver antenna or damage may result.

Control Check

IMPORTANT: Perform a control check at the beginning of each boating session, after repair, or after installation of new batteries.

Ensure the receiver antenna is extended properly and all batteries are fully charged.

1. Power ON the transmitter and the boat. **Do not install the boat canopy.**
2. Place the boat securely on the boat stand.

NOTICE: Do not operate the motor without water cooling circulation or damage may result.

3. Check steering and throttle on the transmitter.

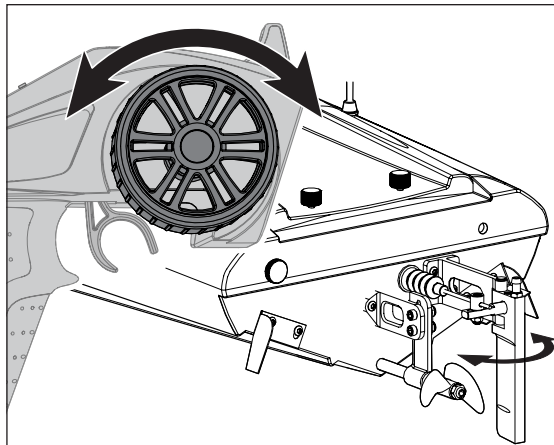

Boating Tips

When running your boat for the first time, we recommend calm wind and water conditions so that you can learn how the boat responds to your control.

Consult local laws and ordinances before choosing a location to pilot your boat.

1. Carefully place the boat in the water.
2. Operate the boat at slow speeds near the shoreline. Avoid objects in the water at all times. When the boat is moving forward, ensure water flows out of the coolant outlet.
3. Once you are comfortable operating the boat at slow speeds, it is safe to operate the boat farther from the shore at higher speeds.
4. Bring the boat back to shore when power is limited by the Low Voltage Cutoff. After LVC has kicked in, the ESC will allow you throttle the boat at a fraction of normal operation allowing enough power to return to shore.

CAUTION: Never operate your boat in less than 12 inches (30.5 cm) of water.

CAUTION: Never attempt to retrieve a downed boat by swimming. If you need to retrieve your boat from the water, use fishing equipment or another boat.

Avoid boating near:

- watercraft
- people (swimming areas, fishing areas)
- stationary objects
- rapidly moving water
- wildlife
- floating debris
- overhanging trees
- vegetation

NOTICE: If the propeller and rudder are blocked with debris or vegetation, remove the boat from the water and remove the debris before continuing operation. Remove any blockage from the coolant system or the motor and ESC (electronic speed control) may overheat.

NOTICE: When running at full speed in choppy waters, the prop may exit and re-enter the water repeatedly and very quickly, subjecting the propeller and drive shaft to some stress. Frequent stress may damage the propeller and drive shaft.

Self-Righting

If the boat turns over, release the throttle until the boat comes to a stop. Return the boat to upright by applying a short throttle burst.

The boat sitting in the water normally leans to the battery side. Applying throttle levels the boat. No weight adjustment is necessary.

NOTICE: The included, weighted motor coupler aids self-righting when full throttle is applied. This coupler is intended for use with the included battery or other batteries with a maximum capacity of 4000mAH. If you run a larger capacity battery pack, replace the weighted coupler with PRB3308 to eliminate erratic boating.

Tip: In calm water, you may need to apply a burst of reverse and then apply a burst of full throttle aid the boat in self-righting. This rocks the boat side to side, aiding it to self-right.

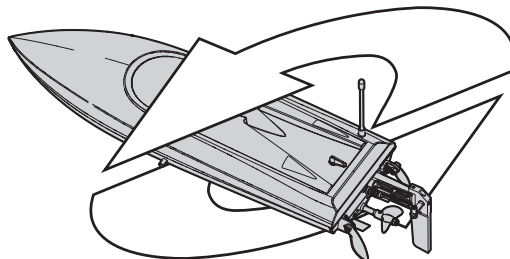

When You Are Finished

1. Power off the receiver by pressing the power button for 2 seconds.
2. Power off the transmitter.
3. Disconnect and remove the battery from the boat.

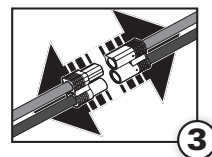
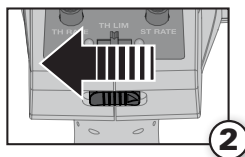
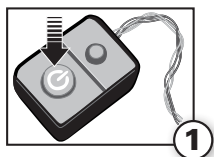

Tip: Always remove the canopy before storage or moisture may allow mold and mildew to grow in the boat. Drain water from inside the hull using the drain plug.

- Fully dry the inside and outside of the boat, including the water cooling lines and jacket around the motor
- Remove the hatch before storing your boat
- Repair any damage or wear to the boat
- Lubricate the drive shaft using Dynamite Marine Grease (DYNE4200)
- Make note of lessons learned from the trimming of your boat, including water and wind conditions

Tip: The hook and loop strips in the boat retain water. To dry them, press on them with a dry cloth.

NOTICE: When you are finished boating, never leave the boat in direct sunlight or in a hot, enclosed area such as a car. Doing so can damage the boat.

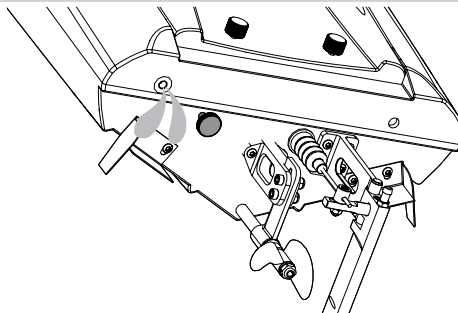

Maintenance

Drivetrain Lubrication

Always replace the drivetrain parts when they are damaged or show visible wear or injury and damage may result.

Lubricating the drive shaft is vital to the life of the drivetrain. The lubricant also acts as a water seal, keeping water from entering the hull through the stuffing tube.

Lubricate the drive shaft and all moving parts after every 30 minutes of operation. Lubricate the drive strut after every 30 minutes of operation.

1. In the hull, use 2 10mm open-end wrenches to loosen the collet nut (C) from the drive shaft (B).
2. Slide the drive shaft out from the stuffing tube and drive strut at the rear of the boat.
3. Wipe the old lubricant and material from the drive shaft.
4. Lubricate the full length of the drive shaft assembly up to the drive dog using marine grease (DYNE4200 or DYNE4201).

NOTICE: When lubricating the flex shaft, do not lubricate the first 20mm of the flex shaft. If grease gets into the motor coupler, it may cause the flex shaft to slip inside of the coupler, thereby damaging it and requiring replacement.

5. Carefully reinstall the drive shaft, ensuring that there is a 2mm gap between the stuffing tube and the drive dog.

NOTICE: Running the boat in saltwater could cause some parts to corrode. If you run the boat in saltwater, rinse it thoroughly in freshwater after each use and lubricate the drive system. Use water displacement spray sparingly.

NOTICE: Because of its corrosive effects, running RC boats in saltwater is at the discretion of the modeler.

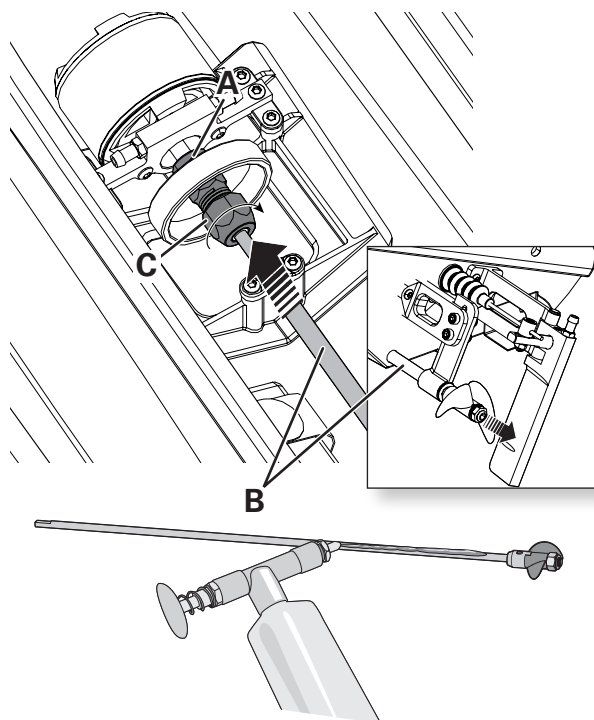

Propeller Service

1. Use an 7mm nut driver to loosen the nut **(A)** from the driveshaft **(B)**.
2. Remove the nut and propeller **(C)** from the driveshaft.
3. Assemble in reverse order. Correctly align the propeller with the drive dog on the driveshaft.

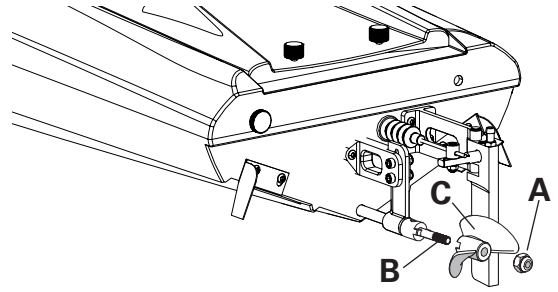

Rudder Service

1. Loosen the setscrew **(A)** on the rudder arm using a 2mm hex wrench, then remove the linkage **(B)** from the rudder arm.
2. Loosen the setscrew **(C)** from the rudder pin **(D)** using a 2mm hex wrench.
3. Turn over the boat and lightly tap the rudder to remove the pin.
4. Assemble in reverse order.

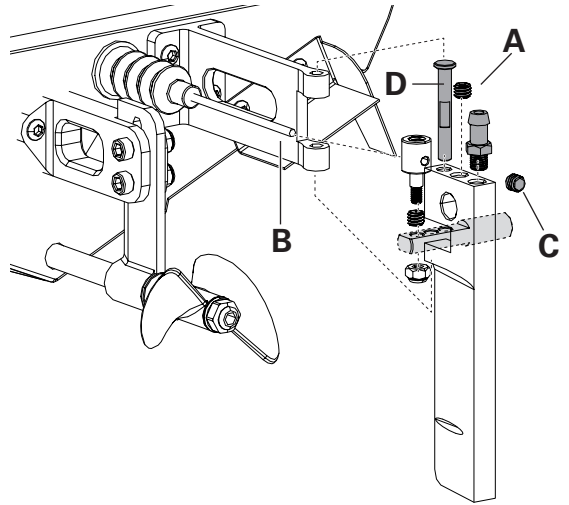

Rudder Trim

If the boat does not go straight, adjust the steering trim dial on the transmitter.

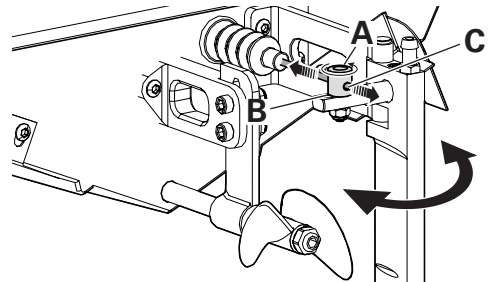
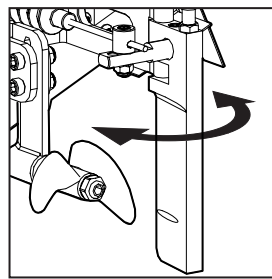
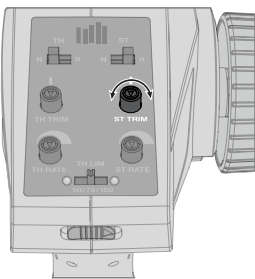

If you are using all the steering trim on your transmitter to make the boat drive straight, return the trim to neutral and mechanically center the rudder. To do this, loosen the hex nut **(A)** from the rudder horn **(B)**, then adjust the linkage **(C)** until the rudder is properly centered.

Water Cooling System

If water does not stream out of the water outlets while the boat is moving forward, immediately stop the boat and clean the obstruction from the water cooling system.

1. Disassemble and clean the water cooling system to remove blockage and prevent overheating.
2. Replace any damaged parts.

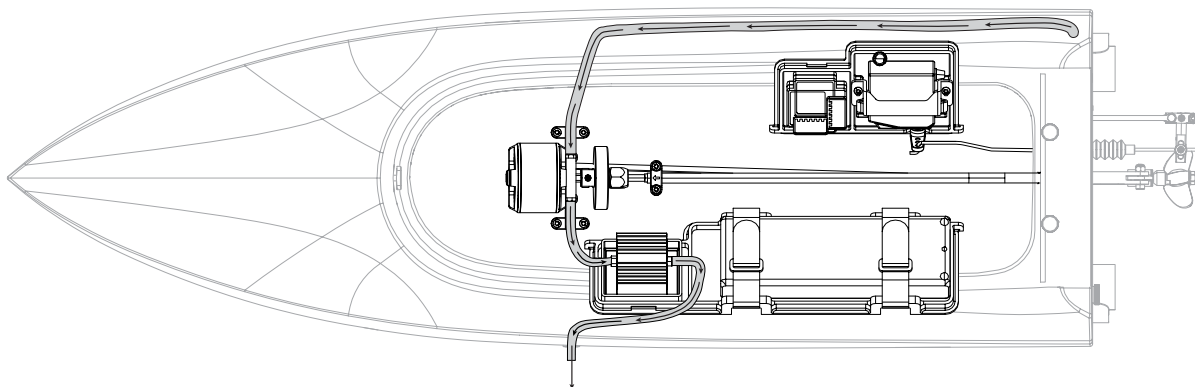

Binding

Binding is the process of programming the receiver to recognize the GUID (Globally Unique Identifier) code of a single specific transmitter. **The STX2™ transmitter and SPMSRX200 receiver are bound at the factory.** If you need to rebind, follow the instructions below:

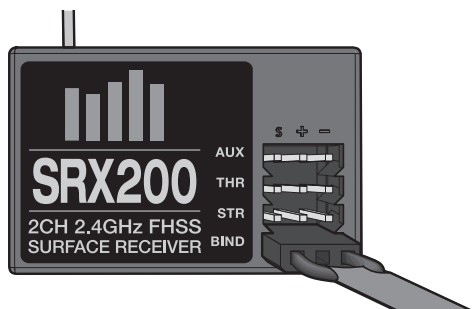

1. Insert the Bind Plug in the BIND port of the ESC.
2. Connect a fully charged battery to the ESC.
3. Power on the ESC. The red receiver LED flashes, indicating the receiver is in bind mode.

4. Center the ST TRIM and TH TRIM dials on the transmitter.
5. Turn the Steering Wheel to Full Right. Power ON the transmitter while holding the Steering Wheel to the Right.
6. Release the Steering Wheel when the receiver LED goes solid.
7. Remove the Bind Plug and store it in a convenient place.
8. Power OFF the ESC to save the settings.
9. Power OFF the transmitter.

You must rebind when:

- You want different failsafe positions (e.g. when throttle or steering reverse has been changed).
- Binding the receiver to a different transmitter.

NOTICE: Do not attempt to bind the transmitter and receiver if there are other compatible transmitters in bind mode within 400 feet. Doing so may result in unexpected binding.



Failsafe

In the unlikely event that the radio connection is lost during use, the receiver will drive the servos to their pre-programmed failsafe positions (normally no throttle and straight steering).

If the receiver is powered on before powering on the transmitter, the receiver will enter this failsafe mode. When the transmitter is powered on, normal control is resumed.

Transmitter Calibration

The ESC has an auto calibration feature. If you rebind or decide to use another transmitter, it may be necessary to calibrate your transmitter to the ESC so that it learns the transmitter's throttle range.

1. Remove the propeller.
2. Ensure that the throttle trim is neutral.
3. Power on transmitter.
4. Move the transmitter's throttle lever to full throttle, holding that position.
5. Press the power button to turn on the ESC while holding full throttle on the transmitter.
6. The ESC will emit 2 tones, acknowledging full throttle.
7. Return the throttle to a neutral position. The ESC will emit one tone.
8. Move the transmitter's throttle lever to full reverse. The ESC will emit 3 tones.
9. Return the throttle to a neutral position. The ESC is now calibrated to the transmitter throttle range.

Transmitter Programing

1. Pull and hold the Throttle Trigger to full throttle and turn the ESC on.
2. After 2 seconds a "**-B-B**" will sound. Wait another 5 seconds and the ESC will give a rising tone to indicate you have entered **Programming Mode**.
3. After entering Programming Mode, you will hear 4 tones in a loop, indicating **Programmable Items**. Push the Throttle Trigger to full brake within 3 seconds after the tone sounds matching the programmable item you want to select.
4. After selecting a programmable item, you will hear several tones in a loop indicating **Programmable Values**. Pull Throttle Trigger to full throttle to select the value matching the tone. The ESC will give an alternating tone to indicate the item is selected.
5. Keep the trigger in Full Throttle to return to **Step 3** and continue item selection. Move the throttle stick to full brake position within 2 seconds to exit the Program Mode.

The black-shaded setting is the factory default

Programmable Items	Programmable Value				-B Single Beep B— Long Beep			
	-B	-B-B	-B-B-B	-B-B-B-B	B—	B— -B	B— -B-B	B— -B-B-B
Running Mode -B	Forward Only	Forward/ Backward						
Li-Po Cells -B-B	Auto Calc.	2s	3s	4s	5s	6s		
Low Voltage Cutoff -B-B-B	None	2.8V/Cell	3.0V/Cell	3.2V/Cell	3.4V/Cell			
Timing -B-B-B-B	0.00°	3.75°	7.50°	11.25°	15.00°	18.75°	22.50°	26.25°

Troubleshooting Guide

Problem	Possible Cause	Solution
Boat will not respond to throttle but responds to other controls	Throttle channel is reversed	Reverse throttle channel on transmitter
Extra noise or extra vibration	Damaged propeller, shaft or motor	Replace damaged parts
	Propeller is out of balance	Balance or replace propeller
Reduced runtime or boat underpowered	Boat battery charge is low	Completely recharge battery
	Boat battery is damaged	Replace boat battery and follow battery instructions
	Blocking or friction on shaft or propeller	Disassemble, lubricate and correctly align parts
	Boat conditions may be too cold	Make sure the battery is warm (above 10° C [50° F]) before use
	Battery capacity may be too low for conditions	Replace battery or use a larger capacity battery
	Drive dog is too near the stuffing tube	Loosen drive shaft side of the motor coupling and move drive shaft small amount back
	Too little lubrication on drive shaft	Fully lubricate drive shaft
	Vegetation or other obstacles block the rudder or propeller	Remove vegetation or obstacles from rudder or propeller
Boat will not Bind (during binding) to transmitter	Transmitter is too near boat during binding process	Move powered transmitter a few feet from boat, disconnect and reconnect battery to boat
	Boat or transmitter is too close to large metal object, wireless source or another transmitter	Move the boat and transmitter to another location and attempt binding again
	Another compatible transmitter is powered on within range of the receiver	Power off all compatible transmitters except the one you are trying to bind
	Boat battery/Transmitter battery charge is too low	Replace/recharge batteries
	ESC switch is off	Power on ESC switch
Boat will not connect (after binding) to transmitter	Transmitter is too near boat during connecting process	Move powered transmitter a few feet from boat, disconnect and reconnect battery to boat
	Boat or transmitter is too close to large metal object, wireless source or another transmitter	Move boat or transmitter to another location and attempt to connect again
	Boat battery/transmitter battery charge is too low	Replace/recharge batteries
	ESC switch is off	Power on ESC switch
Boat tends to dive in the water or takes on water	The boat hull is not completely closed	Dry out the boat and ensure the hatch is fully closed on the hull before returning the boat to the water
	Center of gravity is too far forward	Move batteries back in the hull
	Trim tabs are angled incorrectly	Angle each trim tab up a small amount to lift the bow or down a small amount to lower the bow
Boat tends to turn one direction	Rudder or rudder trim is not centered	Repair rudder or adjust rudder and rudder trim for straight running when control is at neutral
	Vertical fins are angled incorrectly	Adjust the right or left fin angle for straight running when control is at neutral
Rudder does not move	Rudder, linkage or servo damage	Replace or repair damaged parts and adjust controls
	Steering servo wire is damaged or connections are loose	Do a check of steering servo wires and connections, connect or replace as needed
	Transmitter is not bound correctly	Re-bind
	BEC (Battery Elimination Circuit) of the ESC is damaged	Replace ESC
Controls reversed	ESC switch is off	Power on ESC switch
	Transmitter settings are reversed	Perform the Control Direction Test and adjust controls on transmitter appropriately
Motor overheats	Blocked water cooler tubes	Clean or replace water tubes
Motor power pulses then motor loses power	Weather conditions might be too cold	Postpone until weather is warmer
	Battery is old, worn out or damaged	Replace battery

Limited Warranty

What This Warranty Covers

Horizon Hobby, LLC, (Horizon) warrants to the original purchaser that the product purchased (the "Product") will be free from defects in materials and workmanship at the date of purchase.

What is Not Covered

This warranty is not transferable and does not cover (i) cosmetic damage, (ii) damage due to acts of God, accident, misuse, abuse, negligence, commercial use, or due to improper use, installation, operation or maintenance, (iii) modification of or to any part of the Product, (iv) attempted service by anyone other than a Horizon Hobby authorized service center, (v) Product not purchased from an authorized Horizon dealer, or (vi) Product not compliant with applicable technical regulations or (vii) use that violates any applicable laws, rules, or regulations.

OTHER THAN THE EXPRESS WARRANTY ABOVE, HORIZON MAKES NO OTHER WARRANTY OR REPRESENTATION, AND HEREBY DISCLAIMS ANY AND ALL IMPLIED WARRANTIES, INCLUDING, WITHOUT LIMITATION, THE IMPLIED WARRANTIES OF NON-INFRINGEMENT, MERCHANTABILITY AND FITNESS FOR A PARTICULAR PURPOSE. THE PURCHASER ACKNOWLEDGES THAT THEY ALONE HAVE DETERMINED THAT THE PRODUCT WILL SUITABLY MEET THE REQUIREMENTS OF THE PURCHASER'S INTENDED USE.

Purchaser's Remedy

Horizon's sole obligation and purchaser's sole and exclusive remedy shall be that Horizon will, at its option, either (i) service, or (ii) replace, any Product determined by Horizon to be defective. Horizon reserves the right to inspect any and all Product(s) involved in a warranty claim. Service or replacement decisions are at the sole discretion of Horizon. Proof of purchase is required for all warranty claims. SERVICE OR REPLACEMENT AS PROVIDED UNDER THIS WARRANTY IS THE PURCHASER'S SOLE AND EXCLUSIVE REMEDY.

Limitation of Liability

HORIZON SHALL NOT BE LIABLE FOR SPECIAL, INDIRECT, INCIDENTAL OR CONSEQUENTIAL DAMAGES, LOSS OF PROFITS OR PRODUCTION OR COMMERCIAL LOSS IN ANY WAY, REGARDLESS OF WHETHER SUCH CLAIM IS BASED IN CONTRACT, WARRANTY, TORT, NEGLIGENCE, STRICT LIABILITY OR ANY OTHER THEORY OF LIABILITY, EVEN IF HORIZON HAS BEEN ADVISED OF THE POSSIBILITY OF SUCH DAMAGES. Further, in no event shall the liability of Horizon exceed the individual price of the Product on which liability is asserted. As Horizon has no control over use, setup, final assembly, modification or misuse, no liability shall be assumed nor accepted for any resulting damage or injury. By the act of use, setup or assembly, the user accepts all resulting liability. If you as the purchaser or user are not prepared to accept the liability associated with the use of the Product, purchaser is advised to return the Product immediately in new and unused condition to the place of purchase.

Law

These terms are governed by Illinois law (without regard to conflict of law principals). This warranty gives you specific legal rights, and you may also have other rights which vary

from state to state. Horizon reserves the right to change or modify this warranty at any time without notice.

WARRANTY SERVICES

Questions, Assistance, and Services

Your local hobby store and/or place of purchase cannot provide warranty support or service. Once assembly, setup or use of the Product has been started, you must contact your local distributor or Horizon directly. This will enable Horizon to better answer your questions and service you in the event that you may need any assistance. For questions or assistance, please visit our website at www.horizonhobby.com, submit a Product Support Inquiry, or call the toll free telephone number referenced in the Warranty and Service Contact Information section to speak with a Product Support representative.

Inspection or Services

If this Product needs to be inspected or serviced and is compliant in the country you live and use the Product in, please use the Horizon Online Service Request submission process found on our website or call Horizon to obtain a Return Merchandise Authorization (RMA) number. Pack the Product securely using a shipping carton. Please note that original boxes may be included, but are not designed to withstand the rigors of shipping without additional protection. Ship via a carrier that provides tracking and insurance for lost or damaged parcels, as Horizon is not responsible for merchandise until it arrives and is accepted at our facility. An Online Service Request is available at http://www.horizonhobby.com/content/service-center_render-service-center. If you do not have internet access, please contact Horizon Product Support to obtain a RMA number along with instructions for submitting your product for service. When calling Horizon, you will be asked to provide your complete name, street address, email address and phone number where you can be reached during business hours. When sending product into Horizon, please include your RMA number, a list of the included items, and a brief summary of the problem. A copy of your original sales receipt must be included for warranty consideration. Be sure your name, address, and RMA number are clearly written on the outside of the shipping carton.

NOTICE: Do not ship LiPo batteries to Horizon. If you have any issue with a LiPo battery, please contact the appropriate Horizon Product Support office.

Warranty Requirements

For Warranty consideration, you must include your original sales receipt verifying the proof-of-purchase date. Provided warranty conditions have been met, your Product will be serviced or replaced free of charge. Service or replacement decisions are at the sole discretion of Horizon.

Non-Warranty Service

Should your service not be covered by warranty, service will be completed and payment will be required without notification or estimate of the expense unless the expense exceeds 50% of the retail purchase cost.

By submitting the item for service you are agreeing to payment of the service without notification. Service estimates are available upon request. You must include this request with your item submitted for service. Non-warranty

service estimates will be billed a minimum of ½ hour of labor. In addition you will be billed for return freight. Horizon accepts money orders and cashier's checks, as well as Visa, MasterCard, American Express, and Discover cards. By submitting any item to Horizon for service, you are agreeing to Horizon's Terms and Conditions found on our website http://www.horizonhobby.com/content/service-center_render-service-center.

⚠ ATTENTION: Horizon service is limited to Product compliant in the country of use and ownership. If received, a non-compliant Product will not be serviced. Further, the sender will be responsible for arranging return shipment of the un-serviced Product, through a carrier of the sender's choice and at the sender's expense. Horizon will hold non-compliant Product for a period of 60 days from notification, after which it will be discarded.

10/15

Contact Information

Country of Purchase	Horizon Hobby	Contact Information	Address
United States of America	Horizon Service Center (Repairs and Repair Requests)	servicecenter.horizonhobby.com/RequestForm/	4105 Fieldstone Rd Champaign, Illinois 61822 USA
	Horizon Product Support (Product Technical Assistance)	productsupport@horizonhobby.com 888-959-2306	
	Sales	sales@horizonhobby.com 888-959-2306	
European Union	Horizon Technischer Service Sales: Horizon Hobby GmbH	service@horizonhobby.eu +49 (0) 4121 2655 100	Hanskampring 9 D 22885 Barsbüttel, Germany

FCC Statement

FCC ID: 2A13D-SS0001 This equipment has been tested and found to comply with the limits for Part 15 of the FCC rules. These limits are designed to provide reasonable protection against harmful interference in a residential installation. This equipment generates uses and can radiate radio frequency energy and, if not installed and used in accordance with the instructions, may cause harmful interference to radio communications.

However, there is no guarantee that interference will not occur in a particular installation. If this equipment does cause harmful interference to radio or television reception, which can be determined by turning the equipment off and on, the user is encouraged to try to correct the interference by one or more of the following measures:

- Reorient or relocate the receiving antenna.
- Increase the separation between the equipment and receiver.
- Connect the equipment to an outlet on a circuit different from that to which the receiver is connected.

This device complies with part 15 of the FCC rules. Operation is subject to the following two conditions: (1) This device may not cause harmful interference, and (2) this device must accept any interference received, including interference that may cause undesired operation.

NOTICE: Modifications to this product will void the user's authority to operate this equipment.

IC Information

IC ID: 21682-SSTC9202 This device complies with Industry Canada licence-exempt RSS standard(s). Operation is subject to the following two conditions: (1) this device may not cause interference, and (2) this device must accept any interference, including interference that may cause undesired operation of the device.

CE EU Compliance Statement: Horizon Hobby, LLC hereby declares that this product is in compliance with the essential requirements and other relevant provisions of the RED and EMC Directives.

A copy of the EU Declaration of Conformity is available online at: <http://www.horizonhobby.com/content/support-render-compliance>.



Instructions for disposal of WEEE by users in the European Union

This product must not be disposed of with other waste. Instead, it is the user's responsibility to dispose of their waste equipment by handing it over to a designated collections point for the recycling of waste electrical and electronic equipment. The separate collection and recycling of your waste equipment at the time of disposal will help to conserve natural resources and ensure that it is recycled in a manner that protects human health and the environment. For more information about where you can drop off your waste equipment for recycling, please contact your local city office, your household waste disposal service or where you purchased the product.



Replacement Parts / Ersatzteile / Pièces de rechange / Pezzi di ricambio

Part #	English	Deutsch	Français	Italiano
DYN4114CA	10W LiPo AC Balancer Charger	Dynamite 10W LiPo AC Balance Ladegerät-EU	Chargeur AC automatique 10W pour Li-Po	10W LiPo AC Caricabatteria con bilanciatore
DYNB3820EC	11.1V 3200mAh 2S 30C LiPo: EC3	11.1V 3200mAh 2S 30C LiPo: EC3	Batterie Li-Po 2S 11,1V 3200mA 30C avec prise EC3	11,1V 3200mAh 2S 30C LiPo: EC3
DYNM3951	2100Kv 14-Pole BL Outrunner Motor, 33mmx42mm	14P Brushless 33x42mm Outrunner Marine Motor	Moteur Brushless 14 pôles à cage tournante 2100Kv, 33mmx42mm	2100Kv motore outrunner BL14 poli, 33mmx42mm
PRB281011	Rudder & Rudder Mount: BJ24, SW26 V3: Recoil 26	Seitenruder und Seitenruder montieren: BJ24, SW26 V3: Recoil 26	Recoil 26, BJ24, SW26 V3 - Gouvernail	Timone con supporto: BJ24, SW26 V3: Recoil 26
PRB28143	Hull & Decal: Recoil 26	Rumpf & abziehbild: Recoil 26	Recoil 26 - Coque et planche de décoration	Scafo e decalcomanie: Recoil 26
PRB281044	Canopy & Decal: Recoil 26	Überdachung & abziehbild: Recoil 26	Recoil 26 - Cockpit et planche de décoration	Capottina e decalcomanie: Recoil 26
PRB282008	Propeller: 1.34"x2.06"	Schiffsschraube 1,34' x 2,06'	Hélice 1,34"x2,06"	Elica: 1,34"x2,06"
PRB286025	Propeller Strut: Recoil 26	Pro Boat Propeller Strebe: Recoil 26	Recoil 26 -Chaise d'hélice	Montante dell'elica: Recoil 26
PRB286026	Motor Coupler, 5mm Mtr x 3.7mm Flex Shaft: Recoil 26	Pro Boat Motorkupplung, 5mm Mtr x 3.7mm Flexwelle: Recoil 26	Recoil 26 - Accouplement 5mm - 3,7mm	Accoppiatore motore: 5mm motore 3,7mm albero flessibile: Recoil 26
PRB286027	Accessory Pack: Recoil 26	Pro Boat Kleinteile Paket: Recoil 26	Recoil 26 - Accessoires	Pacco accessori: Recoil 26
PRB286028	Radio Trays: Recoil 26	Pro Boat RC Einbauplatte: Recoil 26	Recoil 26 - Platine radio	Supporti batteria: Recoil 26
PRB286032	Motor Mount: Recoil 26	Pro Boat Motorhalter: Recoil 26	Recoil 26 - Support moteur	Supporto motore: Recoil 26
PRB286033	Flex Shaft 3.7mmx348mm & Liner: Recoil 26	Proboat Flexwelle t 3.7mmx348mm & Dichtung: Recoil 26	Recoil 26 - Flexible 3,7mm x 348mm et gaine	Albero flessibile 3,7mmx348mm & guida: Recoil 26
PRB286034	Aluminum Stuffing Tube & Liner: Recoil 26	Proboat Stevenrohr mit Dichtung	Recoil 26 - Tube d'étambot et gaine	Guaina in alluminio con guida: Recoil 26
SPMTX200	SPMSTX200 STX2 2Ch 2.4GHz FHSS Transmitter	Spektrum 2-Kanal 2,4 GHz FHSS Sender	Émetteur FHSS 2,4 GHz 2 canaux Spektrum	Trasmittente Spektrum 2 canali 2,4 GHz FHSS
SPMSRX200	SPMSRX200 STX2 2Ch 2.4GHz FHSS Receiver	Spektrum 2-Kanal 2,4 GHz FHSS Empfänger	Récepteur FHSS 2,4 GHz 2 canaux Spektrum	Ricevente Spektrum 2 canali 2,4 GHz FHSS



Optional Parts / Diverse Teile / Pièces optionnelles / Pezzi opzionali

Part #	English	Deutsch	Français	Italiano
DYN2803	Dynamite Nut Driver: 5.5mm	Dynamite Steckschlüssel: 5.5	Clé à écrou 5,5mm	Dynamite chiave per dadi: 5,5mm
DYN2804	Dynamite Nut Driver: 7mm	Dynamite Steckschlüssel: 7mm	Clé à écrou 7mm	Dynamite chiave per dadi: 7mm
DYN2806	Dynamite 5 pc Metric Hex Driver Assortment	Dynamite Steckschlüsselsortiment 5 St.	Assortiment de 5 clés hexagonales métriques	Dynamite set chiavi esagonali metrici (5 pz)
DYN2815	Dynamite Hex Driver: 2mm	Dynamite metrischer Inbusschlüssel 2 mm	Tournevis hexagonal 2mm	Dynamite chiave esagonale 2mm
DYN2816	Dynamite Hex Driver 2.5mm	Dynamite metrischer Inbusschlüssel 2,5 mm	Tournevis hexagonal 2,5mm	Dynamite chiave esagonale 2,5mm
DYN4071	Li-Po Cell Voltage Checker	Dynamite LiPo-Zellenspannungsmessgerät	Testeur de tension d'élément Li-Po	Li-Po Cell Voltage Checker
DYN4200	Grease Gun with Marine Grease, 5oz.	Marine Fett	Pistolet avec graisse marine 140g	Grasso marino con pistola, 5 oz.
DYN4201	Marine Grease, 5 oz.	Marine Fett	Graisse marine, 140g	Grasso marino, 5 oz.
DYN4401	GPS Speed Meter	Dynamite GPS-Geschwindigkeitsmesser	Tachymètre GPS	GPS Speed Meter
DYNB3803EC	Dynamite Reaction 11.1V 5000mAh 3S LiPo Battery: Hardcase, EC3	Dynamite Reaction 11.1V 5000mAh 3S LiPo Battery: Hardcase, EC3	Batterie Dynamite Reaction Li-Po 3S 11,1V 5000mA 50C, boîtier rigide, prise EC3	Dynamite Reaction 11,1V 5000mAh 3S batteria LiPo: Hardcase, EC3
DYNC0071	Dynamite Charge Adapter: Banana to EC3	Dynamite Ladeadapter Bananenstecker auf Tamiya-Stecker	Cordon de charge - Banane vers EC3	Dynamite Caricabatteria Prophet Sport Plus 50W AC/DC
DYNC2010CA	Prophet Sport Plus 50W AC/DC Charger	Dynamite Prophet Sport Plus 50W Gleich- und Wechselstrom-Ladegerät	Chargeur Prophet plus Sport 50W AC/DC	Dynamite Caricabatteria Prophet Sport Plus 50W AC/DC
DYNK0300	Hook and Loop Tape Set, Waterproof 75x25mm, 4 pcs	Dynamite Klettbandset 75 x 25 (4 Stk)	Adhésif auto-agrippant 75x25mm (4pcs)	Set nastro a strappo, WP 75x25mm, 4 pz
DYNM0102	Clear Flexible Marine Tape (18M)	Dynamite transparentes Marineklebeband 18 m	Adhésif Marin transparent flexible (18M)	Nastro marino trasparente flessibile (18M)
DYNT0502	Start Up Tool Set: ProBoat	Dynamite Startup Werkzeugset: Pro Boat	Pro Boat - Set d'outils de démarrage	Start Up Tool Set: ProBoat
DYNS3005	Dynamite LED Program Card	Dynamite LED Programmierkarte: Marine	Carte de programmation à DELs pour bateau	Dynamite scheda programmazione LED
EFLB32003S30	3200mAh 3S 11.1V 30C LiPo, 12 AWG EC3	3200mAh 3S 11.1V 30C LiPo, 12 AWG EC3	Batterie Li-Po 3S 11,1V 3200mA 30C, prise EC3	3200mAh 3S 11,1V 30C LiPo, 12 AWG EC3
KXSB0017	3200mAh 3S 11.1V 30C LiPo Battery, 12AWG, EC3	3200mAh 3S 11.1V 30C LiPo Battery, 12AWG, EC3	Batterie Li-Po 3S 11,1V 3200mA 30C, prise EC3	3200mAh 3S 11,1V 30C batteria LiPo, 12AWG, EC3
PRB3308	ProBoat Motor Coupler, 5mm (motor) /4mm (flexshaft)	Pro Boat BL-Motormitnehmer	Accouplement moteur Pro Boat: 5mm (moteur) /4mm (Flexible)	ProBoat accoppiatore motore, 5mm (motore)/4mm (albero flessibile)
PRB282006	ProBoat Propeller 1.6x2.5" SS	Pro Boat Schiffsschraube 1,6" x 2,5"	Hélice Pro Boat 1.6"x 2.5"	ProBoat elica 1.6x2.5" SS
SPMSS6170	S6170 Standard Digital Surface Servo: Waterproof	Spektrum S6170 Standard-Digitalservo	Servo digital Standard S6170 pour surface	S6170 Servocomando digitale standard WP

49453.1 Updated: 04/2017
©2017 Horizon Hobby, LLC.

Pro Boat, the Pro Boat logo, Recoil, STX2, Dynamite, ECX, Reaction, Prophet, EC3, and the Horizon Hobby logo are trademarks or registered trademarks of Horizon Hobby, LLC. The Spektrum trademark is used with permission of Bachmann Industries, Inc. Patents pending.

PRB08022