

HORIZON[®]
H O B B Y

Eflite[®]
ADVANCING ELECTRIC FLIGHT

Extra 300 1.3m

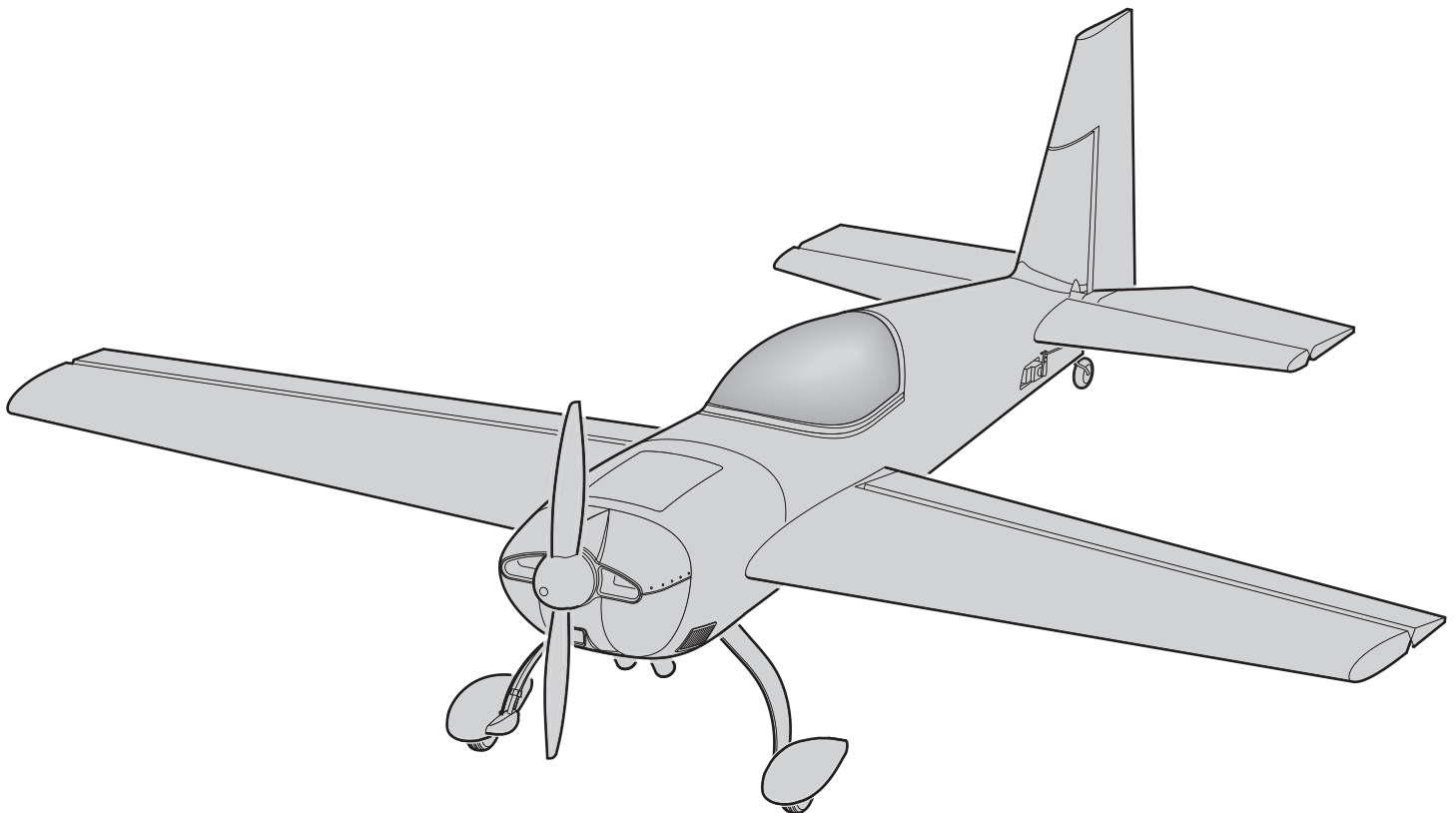

Instruction Manual
Bedienungsanleitung
Manuel d'utilisation
Manuale di Istruzioni

SAFE[®] 

SAFE[®] Select Technology, Optional Flight Envelope Protection

Bind-N-Fly[®] Plug-N-Play[®]
BASIC

NOTICE

All instructions, warranties and other collateral documents are subject to change at the sole discretion of Horizon Hobby, LLC. For up-to-date product literature, visit www.horizonhobby.com and click on the support tab for this product.

Meaning of Special Language:

The following terms are used throughout the product literature to indicate various levels of potential harm when operating this product:

WARNING: Procedures, which if not properly followed, create the probability of property damage, collateral damage, and serious injury OR create a high probability of superficial injury.

CAUTION: Procedures, which if not properly followed, create the probability of physical property damage AND a possibility of serious injury.

NOTICE: Procedures, which if not properly followed, create a possibility of physical property damage AND little or no possibility of injury.



WARNING: Read the ENTIRE instruction manual to become familiar with the features of the product before operating. Failure to operate the product correctly can result in damage to the product, personal property and cause serious injury.

This is a sophisticated hobby product. It must be operated with caution and common sense and requires some basic mechanical ability. Failure to operate this Product in a safe and responsible manner could result in injury or damage to the product or other property. This product is not intended for use by children without direct adult supervision. Do not use with incompatible components or alter this product in any way outside of the instructions provided by Horizon Hobby, LLC. This manual contains instructions for safety, operation and maintenance. It is essential to read and follow all the instructions and warnings in the manual, prior to assembly, setup or use, in order to operate correctly and avoid damage or serious injury.

14+

AGE RECOMMENDATION:
Not for children under 14 years. This is not a toy.



WARNING AGAINST COUNTERFEIT PRODUCTS: If you ever need to replace your Spektrum receiver found in a Horizon Hobby product, always purchase from Horizon Hobby, LLC or a Horizon Hobby authorized dealer to ensure authentic high-quality Spektrum product. Horizon Hobby, LLC disclaims all support and warranty with regards, but not limited to, compatibility and performance of counterfeit products or products claiming compatibility with DSM or Spektrum technology.

Safety Precautions and Warnings

As the user of this product, you are solely responsible for operating in a manner that does not endanger yourself and others or result in damage to the product or the property of others.

- Always keep a safe distance in all directions around your model to avoid collisions or injury. This model is controlled by a radio signal subject to interference from many sources outside your control. Interference can cause momentary loss of control.
- Always operate your model in open spaces away from full-size vehicles, traffic and people.
- Always carefully follow the directions and warnings for this and any optional support equipment (chargers, rechargeable battery packs, etc.).
- Always keep all chemicals, small parts and anything electrical out of the reach of children.
- Always avoid water exposure to all equipment not specifically designed and protected for this purpose. Moisture causes damage to electronics.
- Never place any portion of the model in your mouth as it could cause serious injury or even death.
- Never operate your model with low transmitter batteries.
- Always keep aircraft in sight and under control.
- Always use fully charged batteries.
- Always keep transmitter powered on while aircraft is powered.
- Always remove batteries before disassembly.
- Always keep moving parts clean.
- Always keep parts dry.
- Always let parts cool after use before touching.
- Always remove batteries after use.
- Always ensure failsafe is properly set before flying.
- Never operate aircraft with damaged wiring.
- Never touch moving parts.

Box Contents

| Quick Start Information | | | |
|-------------------------------|---|---------------------|---------------------|
| Transmitter Setup | Set up your transmitter using the transmitter setup chart | | |
| Travel and Dual Rates | | Hi Rate 100% | Low Rate 70% |
| | Ail | 50mm (2 in) | 30mm (1.5 in) |
| | Ele | 60mm (2.38 in) | 45mm (1.75 in) |
| | Rud | 100mm (4 in) | 70mm (2.75 in) |
| Center of Gravity (CG) | 3.5–4.0 in (90–100 mm) from leading edge of wing at the fuselage. | | |
| Flight Timer Setting | 3 minutes | | |

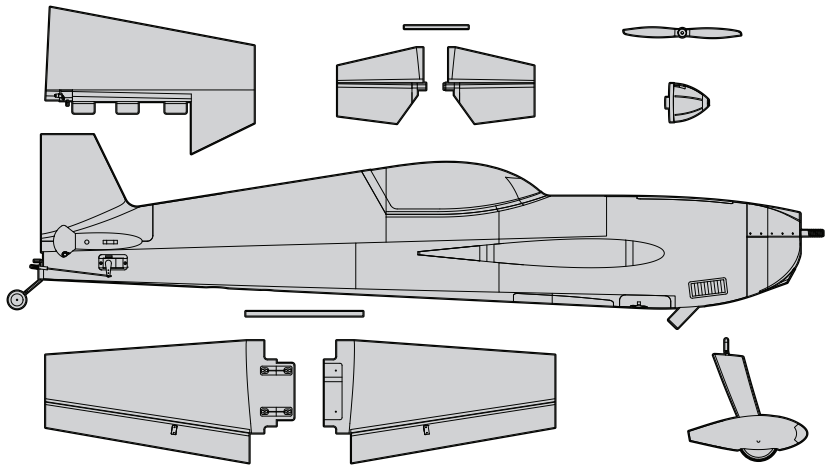

Components

| | | BNF BASIC | PNP PLUG-N-PLAY |
|--|--|-----------------------------|-----------------------------|
| | Motor: 4250-910Kv Motor (EFL11596) | Installed | Installed |
| | ESC: 60A ESC (EFL11597) | Installed | Installed |
| | Servo: 23 gram servo (EFL11598) | Installed | Installed |
| | Receiver: Spektrum™ AR636 6-Channel Sport Receiver (SPMAR636) | Installed | Required to Complete |
| | Recommended Battery: 14.8V 4S 2200-3200mAh 30-40C Li-Po (SPMX22004S30), (KXSB32004S40) | Required to Complete | Required to Complete |
| | Recommended Battery Charger: DYNC2030 Prophet Sport Mini 50W Charger. Optional Charger: DYNC2025 Prophet Sport Duo 50W x 2AC Charger | Required to Complete | Required to Complete |
| | Recommended Transmitter: Full-Range 6 channel (or more) 2.4GHz with Spektrum DSM2®/DSMX® technology with adjustable Dual Rates | Required to Complete | Required to Complete |

Table of Contents

| | |
|--|----|
| Safety Precautions and Warnings | 2 |
| Box Contents | 3 |
| Components | 3 |
| Table of Contents | 3 |
| SAFE® Select Technology (BNF Basic) | 4 |
| Preflight | 4 |
| Transmitter Setup (BNF Basic) | 4 |
| Model Assembly | 5 |
| Transmitter and Receiver Binding / SAFE Select (BNF Basic) | 8 |
| Battery Installation and ESC Arming | 9 |
| SAFE® Select Switch Designation | 10 |
| Control Horn and Servo Arm Settings | 10 |
| Center of Gravity (CG) | 11 |
| AS3X Control Direction Test (BNF Basic) | 11 |
| In Flight Trimming (BNF Basic) | 11 |
| Flying Tips and Repairs | 12 |
| Post Flight | 13 |
| Motor Service | 13 |
| Troubleshooting Guide AS3X | 13 |
| Troubleshooting Guide | 14 |
| AMA National Model Aircraft Safety Code | 15 |
| Limited Warranty | 16 |
| Contact Information | 17 |
| FCC Information | 17 |
| IC Information | 17 |
| Compliance Information for the European Union | 17 |
| Replacement Parts | 65 |
| Optional Parts | 66 |

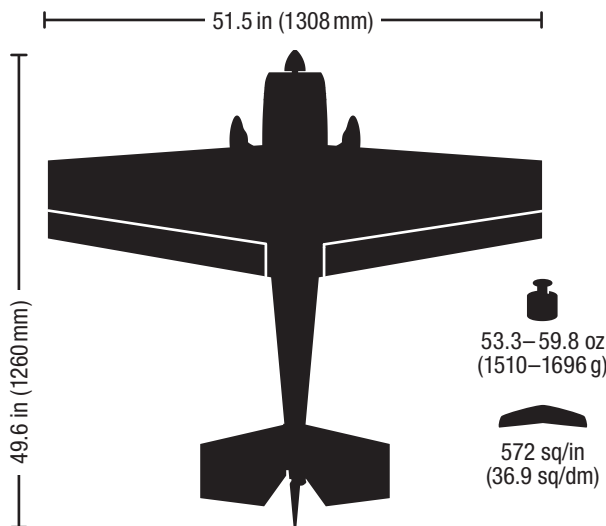

| RECEIVER BIND INFORMATION | |
|---------------------------|-----------------|
| Channels | 6 |
| Frequency | 2405 – 2476 MHz |
| Compatibility | DSM2 and DSMX |

If you own this product, you may be required to register with the FAA.

For up-to-date information on how to register with the FAA, visit <https://registermyuas.faa.gov/>.

For additional assistance on regulations and guidance on UAS usage, visit knowbeforeyoufly.org/.

To receive product updates, special offers and more, register your product at www.horizonhobby.com.

SAFE® Select Technology (BNF Basic)

The evolutionary SAFE® Select technology can offer an extra level of protection so you can perform the first flight with confidence. No complex transmitter programming is required. Just follow the simple bind process to make the SAFE Select system active. When activated, bank and pitch limitations keep you from over-controlling and automatic self-leveling makes recovery from risky or confusing attitudes as simple as releasing the sticks. In fact, with the aileron, elevator and rudder sticks in the neutral position, SAFE Select will automatically keep the airplane in a straight and level attitude.

Expand the advantage of what SAFE® Select technology offers by assigning it to a switch. No transmitter programming is required and you'll be able to turn the system ON and OFF with the flip of a switch. For example, turn SAFE select ON for takeoffs to counter the torque of the propeller. Turn it OFF in flight for unrestricted aerobatic performance, and turn it back ON when a buddy wants to try out your cool aircraft. Turn SAFE Select ON for landings. As you drop the flaps, SAFE Select reduces your workload by compensating for pitch changes automatically, regardless of throttle position. It will help keep the correct pitch attitude and wings level during the final approach. Whether you're a beginner or an expert, SAFE Select can make your flights a great experience.

When the normal bind process is followed, the SAFE Select system is disabled, leaving specially tuned AS3X® technology in place to deliver a pure, unrestricted flight experience.

Preflight

| | |
|---|--|
| 1. Remove and inspect contents. | 9. Make sure linkages move freely. |
| 2. Read this instruction manual thoroughly. | 10. Test the flap operation. |
| 3. Charge the flight battery. | 11. Perform the Control Direction Test with the transmitter. |
| 4. Setup Transmitter using transmitter setup chart. | 12. Perform the AS3X Control Direction Test with the aircraft. |
| 5. Fully assemble the airplane. | 13. Adjust flight controls and transmitter. |
| 6. Install the flight battery in the aircraft (once it has been fully charged). | 14. Perform a radio system Range Test. |
| 7. Check the Center of Gravity (CG). | 15. Find a safe open area to fly. |
| 8. Bind the aircraft to your transmitter. | 16. Plan flight for flying field conditions. |

Transmitter Setup (BNF Basic)

IMPORTANT: After you set up your model, always rebind the transmitter and receiver to set the desired failsafe positions.

Dual Rates

Take first flights in Low Rate. For landings, use high rate elevator.

NOTICE: To ensure AS3X® technology functions properly, do not lower rate values below 50%. If lower rates are desired, manually adjust the position of the pushrods on the servo arm.

NOTICE: If oscillation occurs at high speed, refer to the Troubleshooting Guide for more information.

Expo

If your radio is equipped with Exponential, the values listed in the chart below are a good starting point. After first flights, you may adjust expo in your transmitter.

| | Exponential (Low) Rates | Exponential (High) Rates |
|----------|-------------------------|--------------------------|
| Aileron | 15% | 30% |
| Elevator | 15% | 30% |
| Rudder | 15% | 30% |

Model Assembly

Landing Gear Installation

1. Fit the landing gear into the slot.
2. Install the landing gear cover and secure using four 3 x 15 mm screws.

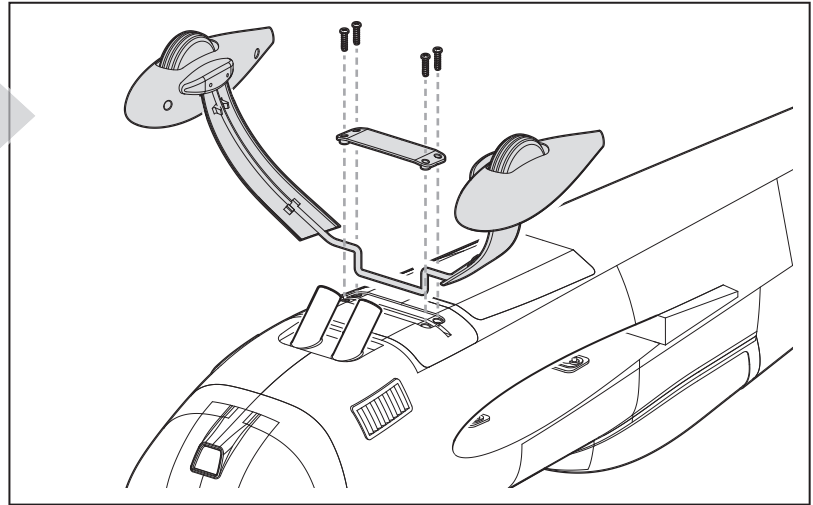

Tail Installation

Horizontal Stabilizer

1. Insert the horizontal stabilizer tube into one of the stab halves.
2. Slide the halves together into the fuselage. Key the mating elevator parts together snugly.
3. Install two 3 x 15 mm screws to secure the stab halves.
4. Insert the Z-Bend of the pushrod into the outside hole of the elevator servo arm and press the elevator pushrod end onto the elevator control horn ball.

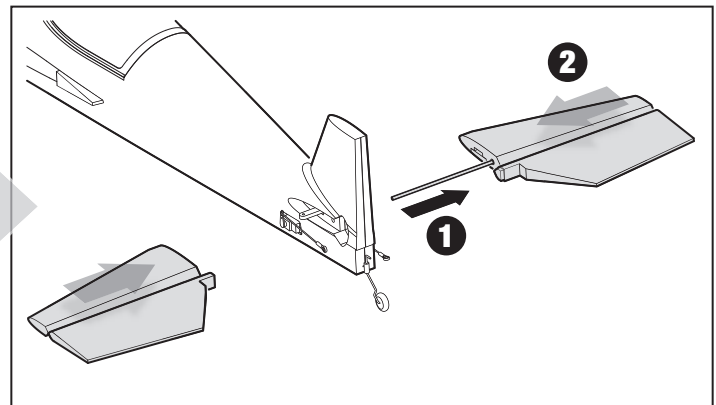

Vertical Fin

5. Apply epoxy or medium/thick CA glue to the rudder hinge tabs. Slide the hinges into the hinge slot while guiding the tail wheel wire into the bracket. **IMPORTANT:** Do not get glue near the hinge pins. Allow the glue to fully set before continuing.
6. Install the 2 x 8 mm flat head screws into the tail wire bracket on the rudder.
7. Insert the Z-Bend into the outside hole of the rudder servo arm and press the rudder pushrod end onto the rudder control horn ball.

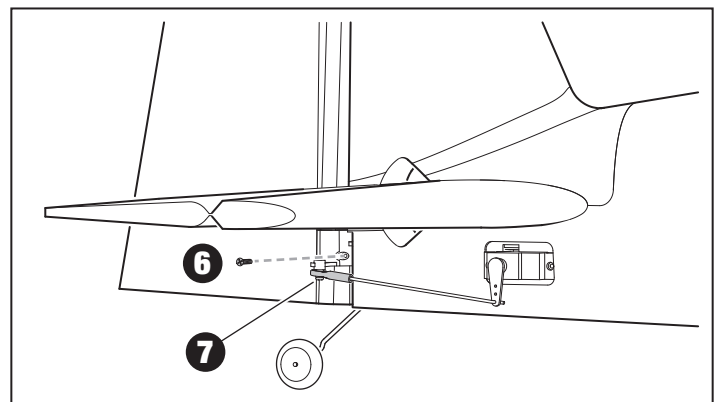
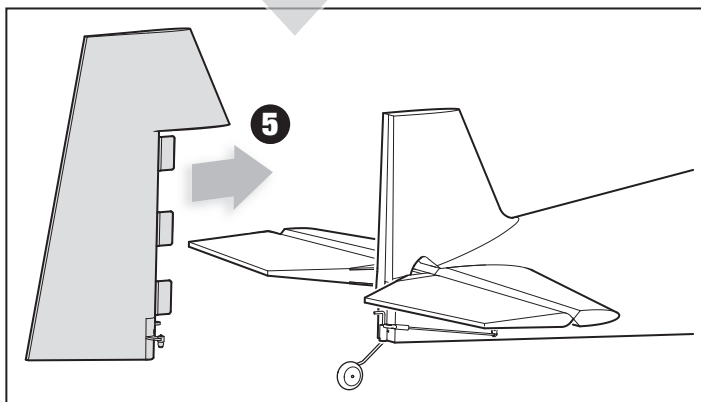
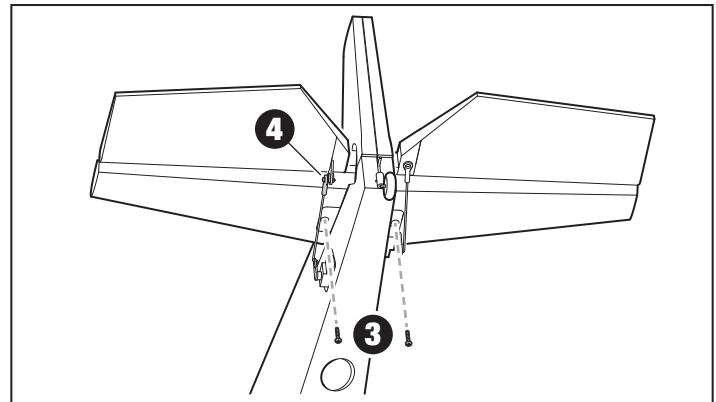

Model Assembly *Continued*

Wing Installation

1. Remove the magnetic bottom hatch cover.
2. Slide the wing joiner into one of the wing panels. Insert that panel into the wing opening in the fuselage and install the other wing panel onto the wing joiner. Make sure the aileron servo leads from each wing are routed inside the wing saddle and out the bottom hatch.

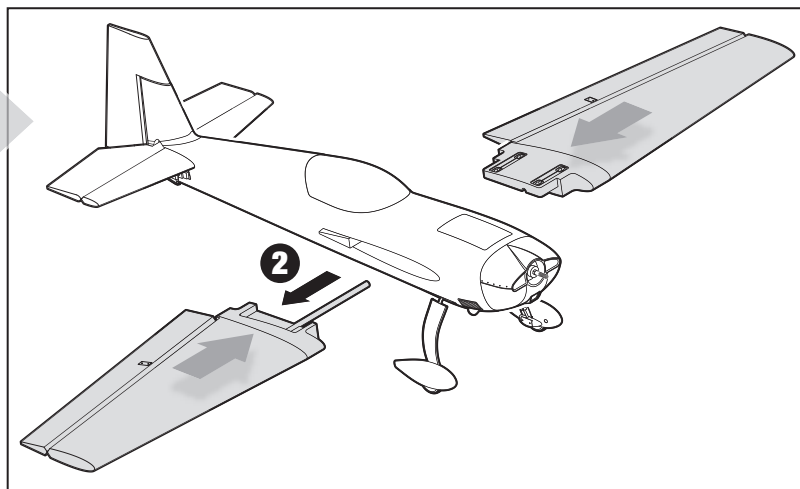

3. Secure the wing panels to the fuselage using four 3 x 30 mm screws.

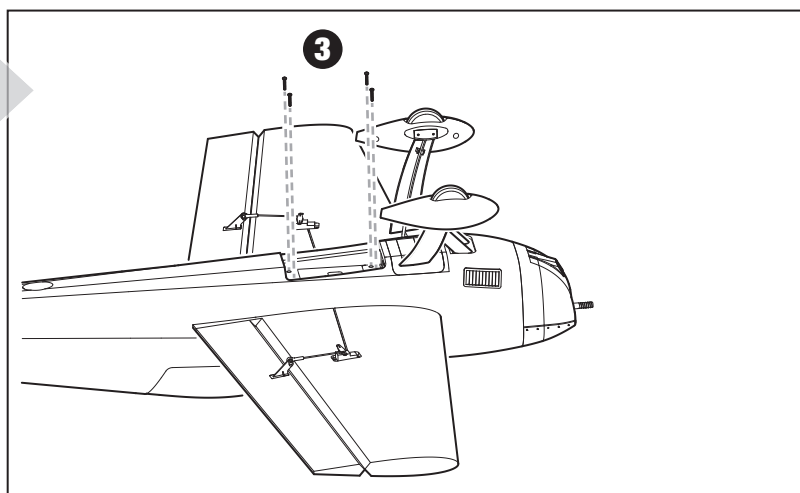

Propeller Installation

1. Install the spinner back plate, propeller, prop washer, and prop nut.
2. Tighten the prop nut until the propeller is installed on the motor shaft securely.
3. Secure the spinner with the 3 x 15 mm screw.

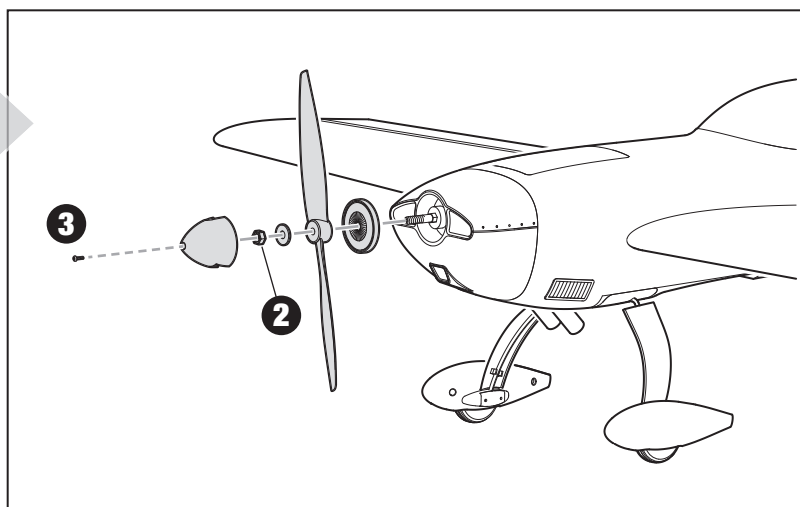

Model Assembly *Continued*

PNP Receiver Selection and Installation

The Spektrum™ AR636 receiver is recommended for this airplane.

If you choose to install another receiver, ensure that it is at least a 4-channel full range receiver. Refer to your receiver manual for correct installation and operation instructions.

Installation (AR636 shown)

1. Remove the magnetic bottom hatch cover.
2. Mount the receiver parallel to the length of the fuselage as shown. Use a small piece from the included hook and loop material.

NOTICE: Incorrect installation of the receiver could cause a crash.

3. Attach the appropriate ESC and servo leads to their respective ports on the receiver using the chart in the illustration.
4. Use the included Y-Harness to connect the two aileron servos.

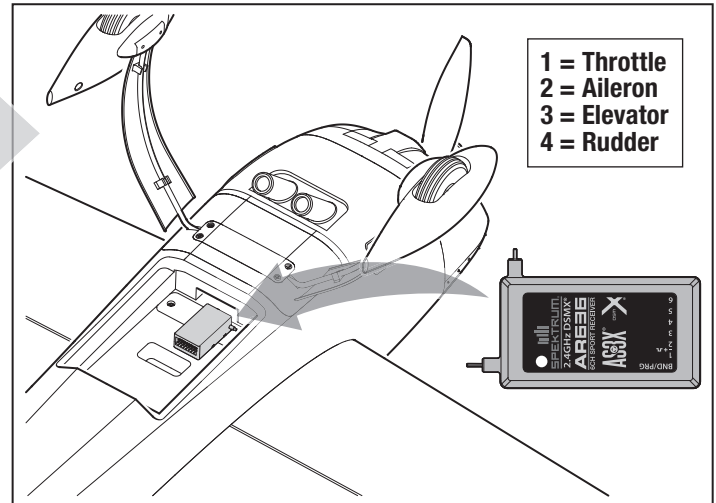

Control Surface Centering

After assembly and transmitter setup, bind a transmitter to the aircraft receiver and set the trims and sub-trims to 0.

If the control surfaces are not centered, adjust the linkages by turning the pushrod end on the linkage to change its length.

- Turn the pushrod end clockwise or counterclockwise until the control surface is centered.
- Attach the linkage to the servo arm or control horn after adjustment.

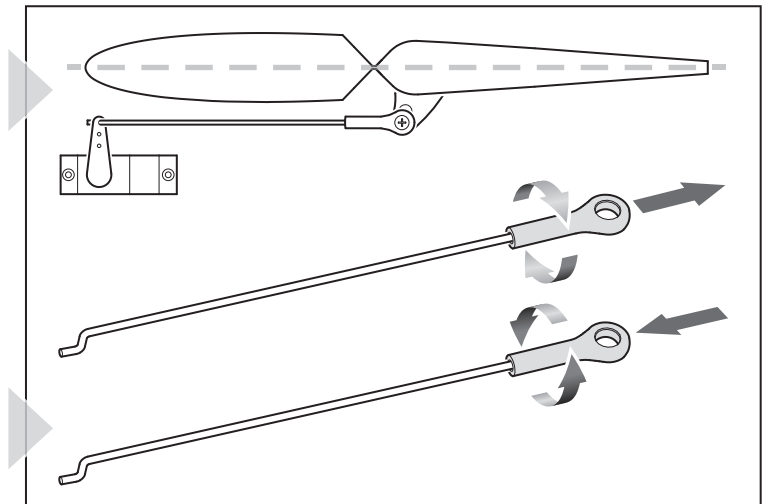

Transmitter and Receiver Binding / Enabling and Disabling SAFE Select (BNF Basic)

This product requires an approved Spektrum™ DSM2®/DSMX® compatible transmitter. Visit www.bindnfly.com for a complete list of approved transmitters.

The aircraft has an optional SAFE Select feature, which can be switched ON or OFF easily by binding in a specific manner as described below.

IMPORTANT: Before binding a transmitter, read the Transmitter Setup section of this manual to ensure that your transmitter is properly programmed for this aircraft.

Bind Plug Installation

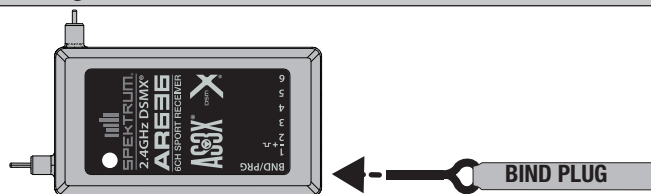

Binding Procedure / Switching ON SAFE Select

IMPORTANT: The included AR636 receiver has been programmed for operation specifically for this aircraft. Refer to the receiver manual for correct setup if the receiver is replaced or is used in another aircraft.

CAUTION: When using a Futaba® transmitter with a Spektrum DSM® module, you must reverse the throttle channel and rebind. Refer to your Spektrum module manual for binding and failsafe instructions. Refer to your Futaba transmitter manual for instructions on reversing the throttle channel.

1. Make sure the transmitter is powered off.
2. Move the transmitter controls to neutral (flight controls: rudder, elevators and ailerons) or to low positions (throttle, throttle trim).*
3. Install a bind plug in the receiver bind port.
4. Place the aircraft level on its wheels, then connect the flight battery to the ESC. The ESC will produce a series of sounds. Three flat tones followed immediately by two ascending tones confirm that the LVC is set correctly for the ESC. The orange bind LED on the receiver will begin to flash rapidly.
5. **Remove the bind plug from the bind port.**
6. Take three steps away from the aircraft /receiver and then power ON the transmitter while holding the transmitter bind button or switch. Refer to your transmitter's manual for specific binding instructions.
IMPORTANT: Do not point the transmitter's antenna directly at the receiver while binding.
IMPORTANT: Keep away from large metal objects while binding.
7. The receiver is bound to the transmitter when the orange bind light on the receiver stays orange. The ESC will produce a series of sounds. Three or four flat tones followed immediately by two ascending tones. The tones indicate the number of cells in the battery and that the ESC is armed, provided the throttle stick and throttle trim are low enough to trigger arming.

IMPORTANT: Once bound, the receiver will retain its bind settings for that transmitter until it has been intentionally changed, even when power is cycled ON and OFF. Repeat the binding process as necessary.

SAFE Select ON Indication

Every time the receiver is powered ON the surfaces will cycle back and forth **twice** with a slight pause at neutral position to indicate that SAFE Select is switched ON.

The throttle will not arm if the transmitter's throttle control is not put at the lowest position. If problems are encountered, follow the binding instructions and refer to the transmitter troubleshooting guide for other instructions. If needed, contact the appropriate Horizon Product Support office.

*Failsafe

If the receiver loses transmitter communication, the failsafe will activate. When activated, failsafe moves the throttle channel to its preset failsafe position (low throttle) that was set during binding. All other channels move to actively level the aircraft in flight.

Switching ON SAFE Select Binding Sequence

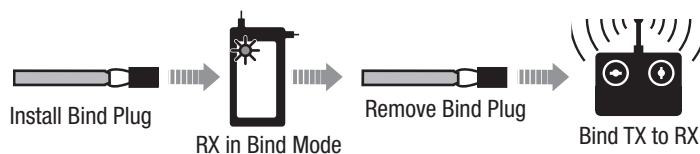

Switching OFF SAFE Select Binding Sequence

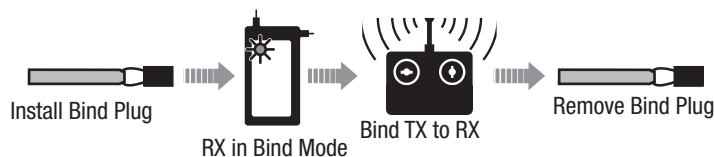

Binding Procedure / Switching OFF SAFE Select

IMPORTANT: The included AR636 receiver has been programmed for operation specifically for this aircraft. Refer to the receiver manual for correct setup if the receiver is replaced or is used in another aircraft.

CAUTION: When using a Futaba® transmitter with a Spektrum DSM® module, you must reverse the throttle channel and rebind. Refer to your Spektrum module manual for binding and failsafe instructions. Refer to your Futaba transmitter manual for instructions on reversing the throttle channel.

1. Make sure the transmitter is powered off.
2. Move the transmitter controls to neutral (flight controls: rudder, elevators and ailerons) or to low positions (throttle, throttle trim).*
3. Install a bind plug in the receiver bind port.
4. Place the aircraft level on its wheels, then connect the flight battery to the ESC. The ESC will produce a series of sounds. Three flat tones followed immediately by two ascending tones confirm that the LVC is set correctly for the ESC.
The orange bind LED on the receiver will begin to flash rapidly. DO NOT remove the bind plug at this time.
5. Take three steps away from the aircraft /receiver and then power ON the transmitter while holding the transmitter bind button or switch. Refer to your transmitter's manual for specific binding instructions.
IMPORTANT: Do not point the transmitter's antenna directly at the receiver while binding.
IMPORTANT: Keep away from large metal objects while binding.
6. The receiver is bound to the transmitter when the orange bind light on the receiver stays orange. The ESC will produce a series of sounds. Three or four flat tones followed immediately by two ascending tones. The tones indicate the number of cells in the battery and that the ESC is armed, provided the throttle stick and throttle trim are low enough to trigger arming.

7. **Remove the bind plug from the bind port.**

IMPORTANT: Once bound, the receiver will retain its bind settings for that transmitter until it has been intentionally changed, even when power is cycled ON and OFF. Repeat the binding process as necessary.

SAFE Select OFF Indication

Every time the receiver is powered ON the surfaces will cycle back and forth **once** to indicate that SAFE Select has been switched OFF.

The throttle will not arm if the transmitter's throttle control is not put at the lowest position. If problems are encountered, follow the binding instructions and refer to the transmitter troubleshooting guide for other instructions. If needed, contact the appropriate Horizon Product Support office.

Battery Installation and ESC Arming

Battery Selection

The Spektrum™ 2200 mAh 14.8V 4S 30C Li-Po battery (SPMX22004S30) is recommended. Refer to the Optional Parts List for other recommended batteries. If using a battery other than those listed, the battery should be within the range of capacity, dimensions and weight of the Spektrum Li-Po battery packs to fit in the fuselage. Be sure the model balances at the recommended CG before flying.

1. Lower the throttle and throttle trim to the lowest settings. Power on the Transmitter, then wait 5 seconds.
2. Lift the hatch by the tab, to remove.
3. Apply the loop side (soft side) of the hook and loop tape to the bottom of your battery and the hook side to the battery tray.
4. Install the fully charged battery in the middle of the battery compartment, as shown. Secure using the hook and loop straps.
5. Connect the battery to the ESC (the ESC is now armed).
6. Keep the aircraft immobile and away from wind, upright and on flat surface or the system will not initialize.
 - The ESC will produce a series of sounds. A single tone followed immediately by three or four tones, which indicates cell count.
 - An LED will light on the receiver.
7. Reinstall the battery hatch.



CAUTION: Always keep hands away from the propeller. When armed, the motor will turn the propeller in response to any throttle movement.

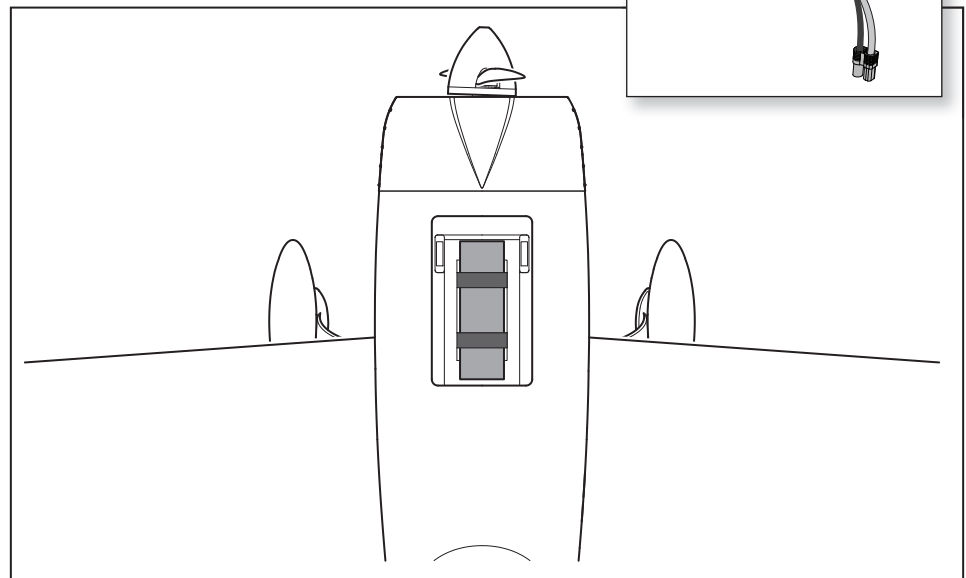
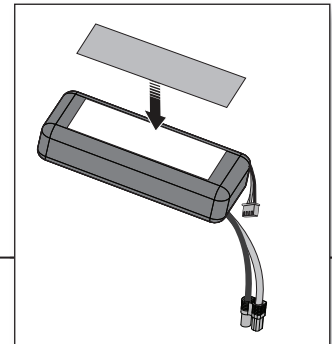
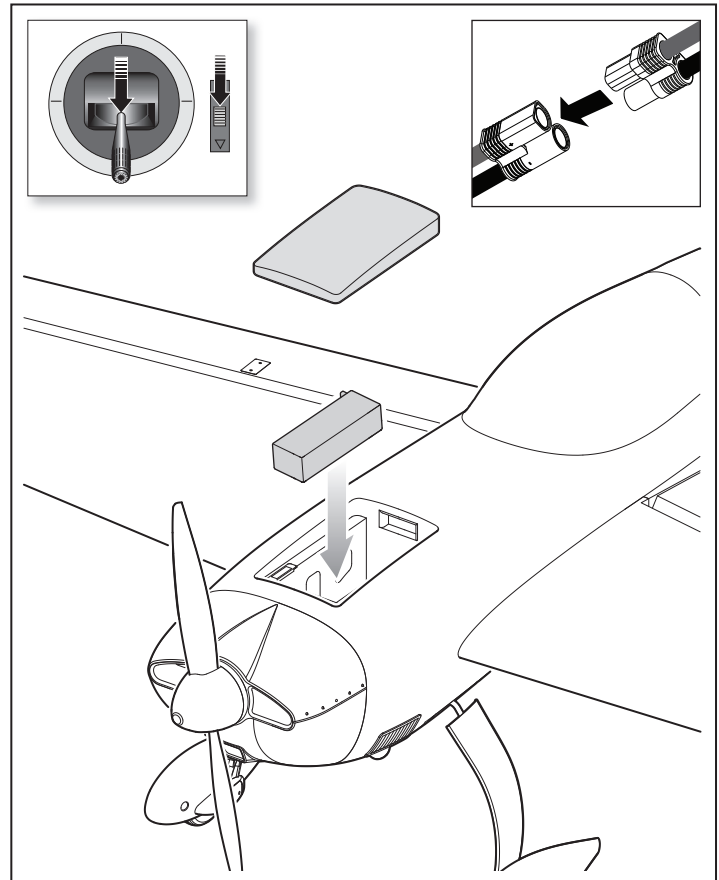

SAFE® Select Switch Designation

SAFE® Select technology can be easily assigned to any open switch (two or three position) on the transmitter. With this new feature, you now have the flexibility to switch SAFE On and Off while in flight.

IMPORTANT: Before assigning your desired switch, ensure that the travel for that channel is set at 100% in both direction.

Assigning a switch

1. Bind the aircraft correctly to activate SAFE Select. This will allow the system to be assigned to a switch.
2. Hold both transmitter sticks to the inside bottom corners and toggle the desired switch five times (one toggle = full up and down) to assign that switch. The control surfaces of the aircraft will move, indicating the switch has been selected.

Repeat the process to assign a different switch if desired.

TIP: SAFE Select is assignable on any unused Channels 5–9

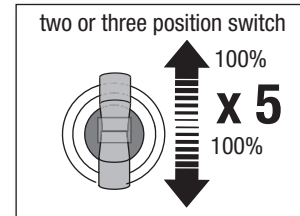
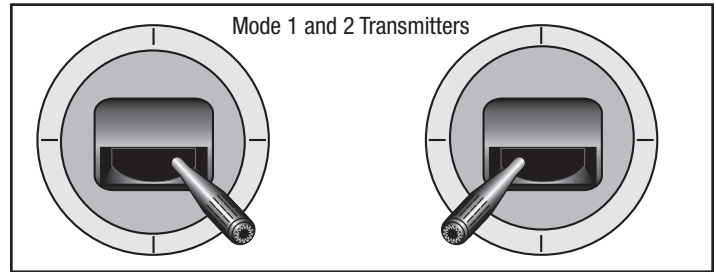

Control Horn and Servo Arm Settings

The table to the right shows the factory settings for the control horns and servo arms. Fly the aircraft at factory settings before making changes.

NOTICE: If control throws are changed from the factory settings, the AR636 gain values may need to be adjusted. Refer to the Spektrum AR636 manual for adjustment of gain values.

After flying, you may choose to adjust the linkage positions for the desired control response. See the table to the right.

| Factory Setting | Control Horns | Servo Arms |
|-----------------|---------------|------------|
| Elevator | | |
| Rudder | | |
| Aileron | | |

| Tuning | Horns | Arms |
|--------------------|-------|------|
| More control throw | | |
| Less control throw | | |

Center of Gravity (CG)

The CG location is measured from the leading edge of the wing at the root. This CG location has been determined with the recommended Li-Po battery (SPMX22004S30).

Tip: Measure the CG with the aircraft inverted.

NOTICE: Install the battery but do not connect the ESC while checking the CG. Personal injury may result.

90–100 mm +/- 3mm
back from leading edge
of wing at the fuselage.

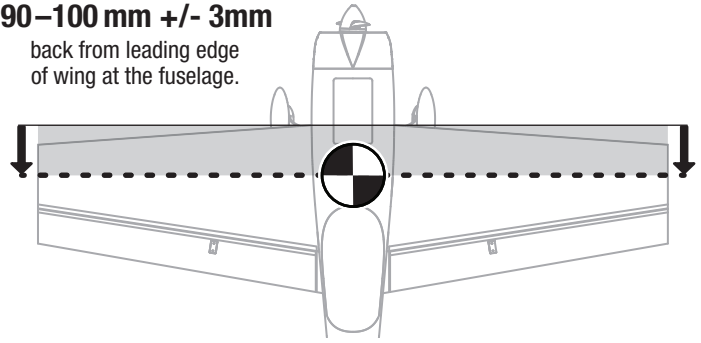

AS3X Control Direction Test (BNF Basic)

This test ensures that the AS3X® control system is functioning properly. Assemble the aircraft and bind your transmitter to the receiver before performing this test.

1. Raise the throttle just above 25%, then lower the throttle to activate AS3X technology.



CAUTION: Keep all body parts, hair and loose clothing away from a moving propeller, as these items could become entangled.

2. Move the entire aircraft as shown and ensure the control surfaces move in the direction indicated in the graphic. If the control surfaces do not respond as shown, do not fly the aircraft. Refer to the receiver manual for more information.

Once the AS3X system is active, control surfaces may move rapidly. This is normal. AS3X remains active until the battery is disconnected.

| | Aircraft movement | AS3X Reaction |
|-----------------|-------------------|---------------|
| Elevator | | |
| | | |
| Aileron | | |
| | | |
| Rudder | | |
| | | |

In Flight Trimming (BNF Basic)

During your first flight, trim the aircraft for level flight at 3/4 throttle. Make small trim adjustments with your transmitter's trim switches to straighten the aircraft's flight path.

After adjusting the trim, do not touch the control sticks for 3 seconds. This allows the receiver to learn the correct settings to optimize AS3X performance.

Failure to do so could affect flight performance.

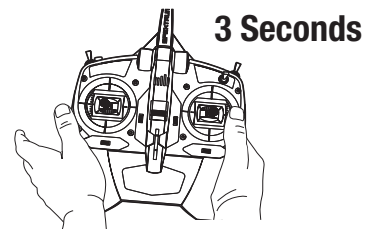

Flying Tips and Repairs

Consult local laws and ordinances before choosing a flying location.

Range Check your Radio System

Before you fly, range check the radio system. Refer to your specific transmitter instruction manual for range test information.

Oscillation

Once the AS3X system is active (after advancing the throttle for the first time), you will normally see the control surfaces react to aircraft movement. In some flight conditions you may see oscillation (the aircraft rocks back and forth on one axis due to overcontrol). If oscillation occurs, refer to the Troubleshooting Guide for more information.

Takeoff

Remember to take off into the wind. When you're ready, set your rudder control rates to high and point the model straight down the runway, hold a bit of up elevator to keep the tail on the ground to maintain tail wheel steering, then gradually advance the throttle. As the model gains speed, decrease up elevator allowing the tail to come off the ground. One of the most important things to remember with a tail dragger is to always be ready to apply right rudder to counteract engine torque. Gain as much speed as your runway and flying site will practically allow before gently applying up elevator, lifting the model into the air.

Flying

For your first flights with the recommended battery pack (SPMX22004S30), set your transmitter timer or a stopwatch to 3 minutes. After 3 minutes, land the aircraft. Adjust your timer for longer or shorter flights once you have flown the model. If at any time the motor power reduces, land the aircraft immediately to recharge the flight battery. See the Low Voltage Cutoff (LVC) section for more details on maximizing battery health and run time.

Landing

To initiate a landing approach, lower the throttle while on the downwind leg. Continue to lose altitude, but maintain airspeed by keeping the nose down as you turn onto the crosswind leg. Make your final turn toward the runway (into the wind) keeping the nose down to maintain airspeed and control. Level the attitude when the model reaches the runway threshold, modulating the throttle as necessary to maintain your glide path and airspeed. If you are going to overshoot, smoothly advance the throttle (always ready on the right rudder to counteract torque). Climb out to make another attempt. When the model is a foot or so off the runway, smoothly increase up elevator until it gently touches down. Once the model is on the runway and has lost flying speed, hold up elevator to place the tail on the ground, regaining tail wheel control.

NOTICE: If a crash is imminent, reduce the throttle and trim fully. Failure to do so could result in extra damage to the airframe, as well as damage to the ESC and motor.

NOTICE: After any impact, always ensure the receiver is secure in the fuselage. If you replace the receiver, install the new receiver in the same orientation as the original receiver or damage may result.

NOTICE: Crash damage is not covered under warranty.

NOTICE: When you are finished flying, never leave the aircraft in direct sunlight or in a hot, enclosed area such as a car. Doing so can damage the aircraft.

NOTICE: Always decrease throttle at propeller strike.

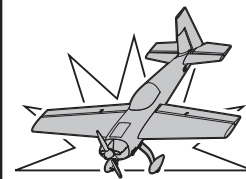

Low Voltage Cutoff (LVC)

When a Li-Po battery is discharged below 3V per cell, it will not hold a charge. The ESC protects the flight battery from over-discharge using Low Voltage Cutoff (LVC). Before the battery charge decreases too much, LVC removes power supplied to the motor. Power to the motor reduces, showing that some battery power is reserved for flight control and safe landing.

Disconnect and remove the Li-Po battery from the aircraft after use to prevent trickle discharge. Charge your Li-Po battery to about half capacity before storage. During storage, make sure the battery charge does not fall below 3V per cell. LVC does not prevent the battery from over-discharge during storage.

NOTICE: Repeated flying to LVC will damage the battery.

Tip: Monitor your aircraft battery's voltage before and after flying by using a Li-Po Cell Voltage Checker (EFLA111, sold separately).

Repairs

Thanks to the EPO foam material in this aircraft, repairs to the foam can be made using virtually any adhesive (hot glue, regular CA, epoxy, etc). When parts are not repairable, see the Replacement Parts List for ordering by item number. For a listing of all replacement and optional parts, refer to the list at the end of this manual.

NOTICE: Use of CA accelerant on your aircraft can damage paint. DO NOT handle the aircraft until accelerant fully dries.

Post Flight

1. Disconnect the flight battery from the ESC (Required for Safety and battery life).
2. Power OFF the transmitter.
3. Remove the flight battery from the aircraft.
4. Recharge the flight battery.

5. Repair or replace all damaged parts.
6. Store the flight battery apart from the aircraft and monitor the battery charge.
7. Make note of the flight conditions and flight plan results, planning for future flights.

Motor Service



CAUTION: Always disconnect the flight battery before performing motor service.

Disassembly

1. Remove the spinner screw and spinner.
2. Use a tool to remove the propeller nut and then the prop washer and prop.
3. Pull off the magnetically held cowl.
4. Remove the four 3 x 15mm self tapping screws and the motor with the X-mount from the fuselage.
5. Disconnect the motor wires from the ESC wires.

Assembly

1. Assemble in reverse order.
 - Correctly align and connect the motor wire colors with the ESC wires.
 - Install the propeller with the numbers facing out from the motor.
 - Tighten the spinner screw to secure the propeller into place.

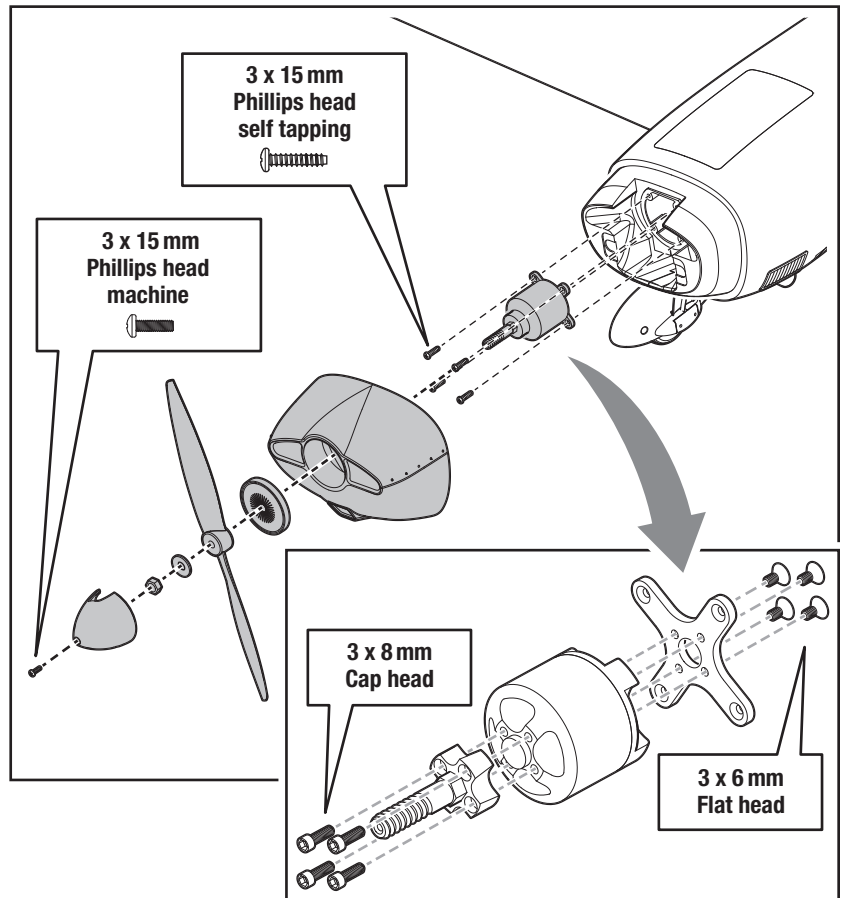

Troubleshooting Guide AS3X

| Problem | Possible Cause | Solution |
|---|---|--|
| Oscillation | Damaged propeller or spinner | Replace propeller or spinner |
| | Imbalanced propeller | Balance the propeller |
| | Motor vibration | Replace parts or correctly align all parts and tighten fasteners as needed |
| | Loose receiver | Align and secure receiver in fuselage |
| | Loose aircraft controls | Tighten or otherwise secure parts (servo, arm, linkage, horn and control surface) |
| | Worn parts | Replace worn parts (especially propeller, spinner or servo) |
| | Irregular servo movement | Replace servo |
| Inconsistent flight performance | Trim is not at neutral | If you adjust trim more than 8 clicks, adjust the clevis to remove trim |
| | Sub-Trim is not at neutral | No Sub-Trim is allowed. Adjust the servo linkage |
| | Aircraft was not kept immobile for 5 seconds after battery connection | With the throttle stick in lowest position. Disconnect battery, then reconnect battery and keep the aircraft still for 5 seconds |
| Incorrect response to the AS3X Control Direction Test | Incorrect direction settings in the receiver, which can cause a crash | DO NOT fly. Correct the direction settings (refer to the receiver manual), then fly |

Troubleshooting Guide

| Problem | Possible Cause | Solution |
|--|--|---|
| Aircraft will not respond to throttle but responds to other controls | Throttle not at idle and/or throttle trim too high | Reset controls with throttle stick and throttle trim at lowest setting |
| | Throttle servo travel is lower than 100% | Make sure throttle servo travel is 100% or greater |
| | Throttle channel is reversed | Reverse throttle channel on transmitter |
| | Motor disconnected from ESC | Make sure motor is connected to the ESC |
| Extra propeller noise or extra vibration | Damaged propeller and spinner, collet or motor | Replace damaged parts |
| | Propeller is out of balance | Balance or replace propeller |
| | Prop nut is too loose | Tighten the prop nut |
| Reduced flight time or aircraft underpowered | Flight battery charge is low | Completely recharge flight battery |
| | Propeller installed backwards | Install propeller with numbers facing forward |
| | Flight battery damaged | Replace flight battery and follow flight battery instructions |
| | Flight conditions may be too cold | Make sure battery is warm before use |
| | Battery capacity too low for flight conditions | Replace battery or use a larger capacity battery |
| Aircraft will not Bind (during binding) to transmitter | Transmitter too near aircraft during binding process | Move powered transmitter a few feet from aircraft, disconnect and re-connect flight battery to aircraft |
| | Aircraft or transmitter is too close to large metal object, wireless source or another transmitter | Move aircraft and transmitter to another location and attempt binding again |
| | The bind plug is not installed correctly in the bind port | Install bind plug in bind port and bind the aircraft to the transmitter |
| | Flight battery/transmitter battery charge is too low | Replace/recharge batteries |
| | Bind switch or button not held long enough during bind process | Power off transmitter and repeat bind process. Hold transmitter bind button or switch until receiver is bound |
| Aircraft will not connect (after binding) to transmitter | Transmitter too near aircraft during connecting process | Move powered transmitter a few feet from aircraft, disconnect and re-connect flight battery to aircraft |
| | Aircraft or transmitter is too close to large metal object, wireless source or another transmitter | Move aircraft and transmitter to another location and attempt connecting again |
| | Bind plug left installed in bind port | Rebind transmitter to the aircraft and remove the bind plug before cycling power |
| | Aircraft bound to different model memory (ModelMatch™ radios only) | Select correct model memory on transmitter |
| | Flight battery/Transmitter battery charge is too low | Replace/recharge batteries |
| | Transmitter may have been bound to a different aircraft using different DSM protocol | Bind aircraft to transmitter |
| Control surface does not move | Control surface, control horn, linkage or servo damage | Replace or repair damaged parts and adjust controls |
| | Wire damaged or connections loose | Do a check of wires and connections, connect or replace as needed |
| | Transmitter is not bound correctly or the incorrect airplanes was selected | Re-bind or select correct airplanes in transmitter |
| | Flight battery charge is low | Fully recharge flight battery |
| | BEC (Battery Elimination Circuit) of the ESC is damaged | Replace ESC |
| Controls reversed | Transmitter settings are reversed | Perform the Control Direction Test and adjust the controls on transmitter appropriately |
| Motor power pulses then motor loses power | ESC uses default soft Low Voltage Cutoff (LVC) | Recharge flight battery or replace battery that is no longer performing |
| | Weather conditions might be too cold | Postpone flight until weather is warmer |
| | Battery is old, worn out, or damaged | Replace battery |
| | Battery C rating might be too small | Use recommended battery |

A. GENERAL

A model aircraft is a non-human-carrying aircraft capable of sustained flight in the atmosphere. It may not exceed limitations of this code and is intended exclusively for sport, recreation, education and/or competition. All model flights must be conducted in accordance with this safety code and any additional rules specific to the flying site.

1. Model aircraft will not be flown:
 - (a) In a careless or reckless manner.
 - (b) At a location where model aircraft activities are prohibited.
2. Model aircraft pilots will
 - (a) Yield the right of way to all man carrying aircraft
 - (b) See and avoid all aircraft and a spotter must be used when appropriate. (AMA Document #540-D.)
 - (c) Not fly higher than approximately 400 feet above ground level within three (3) miles of an airport, without notifying the airport operator.
 - (d) Not interfere with operations and traffic patterns at any airport, heliport or seaplane base except where there is a mixed use agreement.
 - (e) Not exceed a takeoff weight, including fuel, of 55 pounds unless in compliance with the AMA Large Model Aircraft program. (AMA Document 520-A.)
 - (f) Ensure the aircraft is identified with the name and address or AMA number of the owner on the inside or affixed to the outside of the model aircraft. (This does not apply to model aircraft flown indoors).
 - (g) Not operate aircraft with metal-blade propellers or with gaseous boosts except for helicopters operated under the provisions of AMA Document #555.
 - (h) Not operate model aircraft while under the influence of alcohol or while using any drug which could adversely affect the pilot's ability to safely control the model.
 - (i) Not operate model aircraft carrying pyrotechnic devices which explode or burn, or any device which propels a projectile or drops any object that creates a hazard to persons or property.

Exceptions:

 - Free Flight fuses or devices that burn producing smoke and are securely attached to the model aircraft during flight.
 - Rocket motors (using solid propellant) up to a G-series size may be used provided they remain attached to the model during flight. Model rockets may be flown in accordance with the National Model Rocketry Safety Code but may not be launched from model aircraft.
 - Officially designated AMA Air Show Teams (AST) are authorized to use devices and practices as defined within the Team AMA Program Document (AMA Document #718).
 - (j) Not operate a turbine-powered aircraft, unless in compliance with the AMA turbine regulations. (AMA Document #510-A).
3. Model aircraft will not be flown in AMA sanctioned events, air shows or model demonstrations unless:
 - (a) The aircraft, control system and pilot skills have successfully demonstrated all maneuvers intended or anticipated prior to the specific event.
 - (b) An inexperienced pilot is assisted by an experienced pilot.
4. When and where required by rule, helmets must be properly worn and fastened. They must be OSHA, DOT, ANSI, SNELL or NOCSAE approved or comply with comparable standards.

B. RADIO CONTROL

1. All pilots shall avoid flying directly over unprotected people, vessels, vehicles or structures and shall avoid endangerment of life and property of others.
2. A successful radio equipment ground-range check in accordance with manufacturer's recommendations will be completed before the first flight of a new or repaired model aircraft.
3. At all flying sites a safety line(s) must be established in front of which all flying takes place (AMA Document #706.)
 - (a) Only personnel associated with flying the model aircraft are allowed at or in front of the safety line.
 - (b) At air shows or demonstrations, a straight safety line must be established.
 - (c) An area away from the safety line must be maintained for spectators.
 - (d) Intentional flying behind the safety line is prohibited.
4. RC model aircraft must use the radio-control frequencies currently allowed by the Federal Communications Commission (FCC). Only individuals properly licensed by the FCC are authorized to operate equipment on Amateur Band frequencies.
5. RC model aircraft will not operate within three (3) miles of any pre-existing flying site without a frequency-management agreement (AMA Documents #922 and #923.)
6. With the exception of events flown under official AMA Competition Regulations, excluding takeoff and landing, no powered model may be flown outdoors closer than 25 feet to any individual, except for the pilot and the pilot's helper(s) located at the flight line.
7. Under no circumstances may a pilot or other person touch a model aircraft in flight while it is still under power, except to divert it from striking an individual.
8. RC night flying requires a lighting system providing the pilot with a clear view of the model's attitude and orientation at all times. Hand-held illumination systems are inadequate for night flying operations.
9. The pilot of a RC model aircraft shall:
 - (a) Maintain control during the entire flight, maintaining visual contact without enhancement other than by corrective lenses prescribed for the pilot.
 - (b) Fly using the assistance of a camera or First-Person View (FPV) only in accordance with the procedures outlined in AMA Document #550.
 - (c) Fly using the assistance of autopilot or stabilization system only in accordance with the procedures outlined in AMA Document #560.

Please see your local or regional modeling association's guidelines for proper, safe operation of your model aircraft.

Limited Warranty

What this Warranty Covers

Horizon Hobby, LLC, (Horizon) warrants to the original purchaser that the product purchased (the "Product") will be free from defects in materials and workmanship at the date of purchase.

What is Not Covered

This warranty is not transferable and does not cover (i) cosmetic damage, (ii) damage due to acts of God, accident, misuse, abuse, negligence, commercial use, or due to improper use, installation, operation or maintenance, (iii) modification of or to any part of the Product, (iv) attempted service by anyone other than a Horizon Hobby authorized service center, (v) Product not purchased from an authorized Horizon dealer, or (vi) Product not compliant with applicable technical regulations, or (vii) use that violates any applicable laws, rules, or regulations.

OTHER THAN THE EXPRESS WARRANTY ABOVE, HORIZON MAKES NO OTHER WARRANTY OR REPRESENTATION, AND HEREBY DISCLAIMS ANY AND ALL IMPLIED WARRANTIES, INCLUDING, WITHOUT LIMITATION, THE IMPLIED WARRANTIES OF NON-INFRINGEMENT, MERCHANTABILITY AND FITNESS FOR A PARTICULAR PURPOSE. THE PURCHASER ACKNOWLEDGES THAT THEY ALONE HAVE DETERMINED THAT THE PRODUCT WILL SUITABLY MEET THE REQUIREMENTS OF THE PURCHASER'S INTENDED USE.

Purchaser's Remedy

Horizon's sole obligation and purchaser's sole and exclusive remedy shall be that Horizon will, at its option, either (i) service, or (ii) replace, any Product determined by Horizon to be defective. Horizon reserves the right to inspect any and all Product(s) involved in a warranty claim. Service or replacement decisions are at the sole discretion of Horizon. Proof of purchase is required for all warranty claims. SERVICE OR REPLACEMENT AS PROVIDED UNDER THIS WARRANTY IS THE PURCHASER'S SOLE AND EXCLUSIVE REMEDY.

Limitation of Liability

HORIZON SHALL NOT BE LIABLE FOR SPECIAL, INDIRECT, INCIDENTAL OR CONSEQUENTIAL DAMAGES, LOSS OF PROFITS OR PRODUCTION OR COMMERCIAL LOSS IN ANY WAY, REGARDLESS OF WHETHER SUCH CLAIM IS BASED IN CONTRACT, WARRANTY, TORT, NEGLIGENCE, STRICT LIABILITY OR ANY OTHER THEORY OF LIABILITY, EVEN IF HORIZON HAS BEEN ADVISED OF THE POSSIBILITY OF SUCH DAMAGES. Further, in no event shall the liability of Horizon exceed the individual price of the Product on which liability is asserted. As Horizon has no control over use, setup, final assembly, modification or misuse, no liability shall be assumed nor accepted for any resulting damage or injury. By the act of use, setup or assembly, the user accepts all resulting liability. If you as the purchaser or user are not prepared to accept the liability associated with the use of the Product, purchaser is advised to return the Product immediately in new and unused condition to the place of purchase.

Law

These terms are governed by Illinois law (without regard to conflict of law principals). This warranty gives you specific legal rights, and you may also have other rights which vary from state to state. Horizon reserves the right to change or modify this warranty at any time without notice.

WARRANTY SERVICES

Questions, Assistance, and Services

Your local hobby store and/or place of purchase cannot provide warranty support or service. Once assembly, setup or use of the Product has been started, you must contact your local distributor or Horizon directly. This will enable Horizon to better answer your questions and service you in the event that you may need any assistance. For questions

or assistance, please visit our website at www.horizonhobby.com, submit a Product Support Inquiry, or call the toll free telephone number referenced in the Warranty and Service Contact Information section to speak with a Product Support representative.

Inspection or Services

If this Product needs to be inspected or serviced and is compliant in the country you live and use the Product in, please use the Horizon Online Service Request submission process found on our website or call Horizon to obtain a Return Merchandise Authorization (RMA) number. Pack the Product securely using a shipping carton. Please note that original boxes may be included, but are not designed to withstand the rigors of shipping without additional protection. Ship via a carrier that provides tracking and insurance for lost or damaged parcels, as Horizon is not responsible for merchandise until it arrives and is accepted at our facility. An Online Service Request is available at http://www.horizonhobby.com/content/_service-center_render-service-center. If you do not have internet access, please contact Horizon Product Support to obtain a RMA number along with instructions for submitting your product for service. When calling Horizon, you will be asked to provide your complete name, street address, email address and phone number where you can be reached during business hours. When sending product into Horizon, please include your RMA number, a list of the included items, and a brief summary of the problem. A copy of your original sales receipt must be included for warranty consideration. Be sure your name, address, and RMA number are clearly written on the outside of the shipping carton.

NOTICE: Do not ship LiPo batteries to Horizon. If you have any issue with a LiPo battery, please contact the appropriate Horizon Product Support office.

Warranty Requirements

For Warranty consideration, you must include your original sales receipt verifying the proof-of-purchase date. Provided warranty conditions have been met, your Product will be serviced or replaced free of charge. Service or replacement decisions are at the sole discretion of Horizon.

Non-Warranty Service

Should your service not be covered by warranty, service will be completed and payment will be required without notification or estimate of the expense unless the expense exceeds 50% of the retail purchase cost. By submitting the item for service you are agreeing to payment of the service without notification. Service estimates are available upon request. You must include this request with your item submitted for service. Non-warranty service estimates will be billed a minimum of ½ hour of labor. In addition you will be billed for return freight. Horizon accepts money orders and cashier's checks, as well as Visa, MasterCard, American Express, and Discover cards. By submitting any item to Horizon for service, you are agreeing to Horizon's Terms and Conditions found on our website http://www.horizonhobby.com/content/_service-center_render-service-center.

ATTENTION: Horizon service is limited to Product compliant in the country of use and ownership. If received, a non-compliant Product will not be serviced. Further, the sender will be responsible for arranging return shipment of the un-serviced Product, through a carrier of the sender's choice and at the sender's expense. Horizon will hold non-compliant Product for a period of 60 days from notification, after which it will be discarded.

10/15

Contact Information

| Country of Purchase | Horizon Hobby | Contact Information | Address |
|--------------------------|---|---|--|
| United States of America | Horizon Service Center (Repairs and Repair Requests) | servicecenter.horizonhobby.com/ RequestForm/ | 2904 Research Rd Champaign, Illinois, 61822 USA |
| | Horizon Product Support (Product Technical Assistance) | productsupport@horizonhobby.com 877-504-0233 | |
| | Sales | websales@horizonhobby.com 800-338-4639 | |
| European Union | Horizon Technischer Service | service@horizonhobby.eu | Hanskampring 9 D 22885 Barsbüttel, Germany |
| | Sales: Horizon Hobby GmbH | +49 (0) 4121 2655 100 | |

FCC Information

FCC ID: BRWDASRX15

This device complies with part 15 of the FCC rules. Operation is subject to the following two conditions: (1) This device may not cause harmful interference, and (2) this device must accept any interference received, including interference that may cause undesired operation.

CAUTION: Changes or modifications not expressly approved by the party responsible for compliance could void the user's authority to operate the equipment.

This product contains a radio transmitter with wireless technology which has been tested and found to be compliant with the applicable regulations governing a radio transmitter in the 2.400GHz to 2.4835GHz frequency range.

Supplier's Declaration of Conformity

EFL Extra 300 BNF Basic | EFL11550

 This device complies with part 15 of the FCC Rules. Operation is subject to the following two conditions: (1) This device may not cause harmful interference, and (2) this device must accept any interference received, including interference that may cause undesired operation.

CAUTION: changes or modifications not expressly approved by the party responsible for compliance could void the user's authority to operate the equipment.

NOTE: This equipment has been tested and found to comply with the limits for a Class B digital device, pursuant to part 15 of the FCC Rules. These limits are designed to provide reasonable protection against harmful interference in a residential installation. This equipment generates, uses and can radiate radio frequency energy and, if not installed and used in accordance with the instructions, may cause harmful interference to radio communications. However, there is no guarantee that interference will not occur in a particular installation. If this equipment does cause harmful interference to radio or television reception, which can be determined by turning the equipment off and on, the user is encouraged to try to correct the interference by one or more of the following measures:

- Reorient or relocate the receiving antenna.
- Increase the separation between the equipment and receiver.
- Connect the equipment into an outlet on a circuit different from that to which the receiver is connected.
- Consult the dealer or an experienced radio/TV technician for help.

Horizon Hobby, LLC
4105 Fieldstone Rd.,
Champaign, IL 61822
Email: compliance@horizonhobby.com
Web: HorizonHobby.com

IC Information

IC: 6157A-AMRX15

CAN ICES-3 (B)/NMB-3(B)

This device complies with Industry Canada licence-exempt RSS standard(s). Operation is subject to the following two conditions:

(1) this device may not cause interference, (2) this device must accept any interference, including interference that may cause undesired operation of the device.

Compliance Information for the European Union

EU Compliance Statement:

EFL11575 Extra 300 1.3 M PNP; Horizon Hobby, LLC hereby declares that this product is in compliance with the essential requirements and other relevant provisions of the EMC Directive.

EFL11550 Extra 300 1.3 M BNF BASIC; Horizon Hobby, LLC hereby declares that this product is in compliance with the essential requirements and other relevant provisions of the RED and EMC Directives.

A copy of the EU Declaration of Conformity is available online at: <http://www.horizonhobby.com/content/support-render-compliance>.



E328

Instructions for disposal of WEEE by users in the European Union



This product must not be disposed of with other waste. Instead, it is the user's responsibility to dispose of their waste equipment by handing it over to a designated collections point for the recycling of waste electrical and electronic equipment. The separate collection and recycling of your waste equipment at the time of disposal will help to conserve natural resources and make sure that it is recycled in a manner that protects human health and the environment. For more information about where you can drop off your waste equipment for recycling, please contact your local city office, your household waste disposal service or where you purchased the product.

Recommended Receivers • Empfohlene Empfänger Récepteurs Recommandés • Ricevitori Raccomandati

PNP Only • Nur PNP • PNP Uniquement • Solo PNP

| Part # Nummer Numéro Codice | Description | Beschreibung | Description | Descrizione |
|------------------------------------|---|---|---|---|
| SPMAR610 | AR610 6-Channel Coated Air Receiver | Ummantelter AR610-6-Kanal-Flugzeugempfänger | Récepteur aérien avec revêtement 6 canaux AR610 | Ricevente aereo AR610 6 canali con rivestimento |
| | Telemetry Equipped Receivers | Empfänger mit Telemetrie | Récepteurs avec télémétrie | Riceventi con telemetria |
| SPMAR6600T | AR6600T 6-Channel Air Integrated Telemetry Receiver | AR6600T-6-Kanal-Flugzeugempfänger mit integrierter Telemetrie | Récepteur aérien avec télémétrie intégrée 6 canaux AR6600T | Ricevente aereo AR6600T 6 canali con telemetria integrata |
| SPMAR6270T | AR6270T 6-Channel Carbon Fuse Integrated Telemetry Receiver | AR6270T-6-Kanal-Karbon-Sicherungempfänger mit integrierter Telemetrie | Récepteur à fusibles en carbone avec télémétrie intégrée 6 canaux AR6270T | Ricevente AR6270T 6 canali con telemetria integrata per fusoliera in carbonio |
| SPMAR8010T | AR8010T 8-Channel Air Integrated Telemetry Receiver | AR8010T-8-Kanal-Flugzeugempfänger mit integrierter Telemetrie | Récepteur aérien avec télémétrie intégrée 8 canaux AR8010T | Ricevente aereo AR8010T 8 canali con telemetria integrata |
| SPMAR9030T | AR9030T 9-Channel Air Integrated Telemetry Receiver | AR9030T-9-Kanal-Flugzeugempfänger mit integrierter Telemetrie | Récepteur aérien avec télémétrie intégrée 9 canaux AR9030T | Ricevente aereo AR9030T 9 canali con telemetria integrata |
| | AS3X Equipped Receivers | AS3X-Empfänger | Récepteurs avec AS3X | Riceventi con AS3X |
| SPMAR636 | AR636 6-Channel AS3X Sport Receiver | AR636-6-Kanal-AS3X-Sportempfänger | Récepteur AS3X sport 6 canaux AR636 | AR636 ricevitore sportivo a 6 canali AS3X |
| | AS3X and Telemetry Equipped Receivers | AS3X- und Telemetrieempfänger | Récepteurs avec AS3X et télémétrie | Riceventi con AS3X e telemetria |
| SPMAR7350 | AR7350 7-Channel AS3X Receiver with Integrated Telemetry | AR7350-7-Kanal-Empfänger | Récepteur 7 canaux AR7350 | Ricevente AR7350 7 canali |
| SPMAR9350 | AR9350 7-Channel AS3X Receiver with Integrated Telemetry | AR9350-7-Kanal-Empfänger | Récepteur 7 canaux AR9350 | Ricevente AR9350 7 canali |
| | Telemetry Sensors* | Telemetriesensoren* | Capteurs télémétriques* | Sensori di telemetria* |
| SPMA9574 | Aircraft Telemetry Airspeed Indicator | Flugzeugtelemetrie-Luftgeschwindigkeitsanzeige | Indicateur télémétrique de vitesse aérodynamique pour avion | Telemetria per aerei - Anemometro |
| SPMA9589 | Aircraft Telemetry Altitude and Variometer Sensor | Flugzeugtelemetrie-Höhen- und Variometer-Sensor | Indicateur télémétrique d'altitude et variomètre pour avion | Telemetria per aerei - Sensore altimetrico e variometro |
| SPMA9558 | Brushless RPM Sensor | Bürstenloser Drehzahlsensor | Capteur de tr/min sans balai | Sensore RPM brushless |
| SPMA9605 | Aircraft Telemetry Flight Pack Battery Energy Sensor | Flugzeugtelemetrie-Flugakkupack-Energiesensor | Capteur télémétrique de niveau de batterie de vol pour avion | Telemetria per aerei - Sensore per la misura dell'energia della batteria di bordo |
| SPMA9587 | Aircraft Telemetry GPS Sensor | Flugzeugtelemetrie-GPS-Sensor | Capteur télémétrique GPS pour avion | Telemetria per aerei - Sensore GPS |

*Not compatible with BNF, Telemetry receiver required

*Nicht kompatibel mit BNF, Telemetrieempfänger erforderlich

*Non compatible avec les modèles BNF, récepteur télémétrique requis

*Non compatibile con BNF, necessita di ricevente con telemetria

Replacement Parts • Ersatzteile • Pièces de rechange • Pezzi di ricambio

| Part # Nummer Numéro Codice | Description | Beschreibung | Description | Descrizione |
|------------------------------------|--------------------------------|------------------------------------|-------------------------------|---------------------------------------|
| EFL11576 | Fuselage w/Rudder | Rumpf mit Seitenruder | Fuselage avec gouverne | Fusoliera con timone |
| EFL11577 | Wing | Tragflächen | Aile | Ali |
| EFL11578 | Horizontal Stabilizer | Höhenleitwerk | Stabilisateur | Stabilizzatore orizzontale |
| EFL11579 | Cowl | Motorhaube | Capot | Naca motore |
| EFL11580 | Canopy | Kabinenhaube | Verrière | Calotta |
| EFL11581 | Landing Gear Set | Fahrwerk | Train d'atterrissage | Set carrello |
| EFL11582 | Tailwheel Set | Spornradsatz | Roulette de queue | Set ruota posteriore |
| EFL11583 | Spinner | Spinner | Cône | Ogiva |
| EFL11584 | Battery Cover | Akkuhaube | Trappe de batterie | Sportello batteria |
| EFL11585 | Bottom Cover | Untere Abdeckung | Couvercle inférieur | Coperchio inferiore |
| EFL11586 | Linkage Rod | Gestänge | Tringlerie | Aste comandi |
| EFL11587 | Screw Set | Schraubensatz | Ensemble de vis | Set di viti |
| EFL11588 | Wing Tube | Tragfl ächenverbinder | Clé d'aile | Tubo dell'ala |
| EFL11589 | Decal Sheet | Dekorbogen | Planche de décoration | Foglio decorazioni adesive |
| EFL11590 | Landing Gear Insert | Fahrwerkshalter | Bague de train d'atterrissage | Fermo carrello d'atterraggio |
| EFL11591 | Pilot | Pilot | Pilote | Pilota |
| EFL11592 | Propeller | Propeller | Hélice | Elica |
| EFL11593 | Motor Board | Motorhalter | Conseil moteur | Supporto motore |
| EFL11594 | X Motor Mount | X Motorhalter | Support moteur X | X Supporto motore |
| EFL11595 | Motor Shaft | Motorwelle | Axe moteur | Albero motore |
| EFL11596 | Motor | Motor | Moteur | Motore |
| EFL11597 | ESC 60A | 60A ESC Regler | Contrôleur 60A | ESC 60A |
| EFL11598 | 23g MG Servo | 23 Gram Servo | Servo 23 gr | Servocomando 23 g |
| SPMAR636 | AR636 6-Channel Sport Receiver | AR636 6-Kanal AS3X Sport Empfänger | Récepteur AR636 6 voies | Ricevente AR636 AS3X sport a 6 canali |

Optional Parts • Optionale Bauteile • Pièces optionnelles • Pezzi opzionali

| Part # Nummer Numéro Codice | Description | Beschreibung | Description | Descrizione |
|------------------------------------|--|---|---|---|
| EFLA250 | Park Flyer Tool Assortment, 5 pc | Park Flyer Werkzeugsortiment, 5 teilig | Assortiment d'outils park flyer, 5pc | Park Flyer assortimento attrezzi, 5 pc |
| EFLAEC302 | EC3 Battery Connector, Female (2) | EC3 Akkukabel, Buchse (2) | Prise EC3 femelle (2pc) | EC3 Connettore femmina batteria (2) |
| EFLAEC303 | EC3 Device/Battery Connector, Male/Female | EC3 Kabelsatz, Stecker/Buchse | Prise EC3 male/femelle | EC3 Connettore batteria maschio/femmina |
| SPMX22004S30 | 14.4V 4S 30C 2200mAh Li-Po IC3 | 14.4V 4S 30C 2200mAh LiPo IC3 | Li-Po IC3 4S 14,4V 2200mA 30C | 14.4V 4S 30C 2200MAH Li-Po IC3 |
| EFLB32004S30 | 14.4V 4S 30C 3200mAh Li-Po | 14.4V 4S 30C 3200mAh LiPo | Li-Po 4S 14,4V 3200mA 30C | 14.4V 4S 30C 3200MAH Li-Po |
| SPMX22003S30 | 11.1V 3S 30C 2200mAh LiPo IC3 | 11.1V 3S 30C 2200mAh LiPo IC3 | LiPo IC3 3S 11,1V 2200mAh 30C | 11.1V 3S 30C 2200mAh LiPo IC3 |
| SPMX32003S30 | 11.1V 3S 30C 3200mAh Smart LiPo IC3 | 11.1V 3S 30C 3200mAh Smart LiPo IC3 | Smart LiPo IC3 11,1V 3S 3200mAh 30C | 11.1V 3S 30C 3200mAh Smart LiPo IC3 |
| KXSB32004S40 | 14.8V 4S 40C 3200mAh LiPo EC3 LED | 14.8V 4S 40C 3200mAh LiPo EC3 LED | LiPo EC3 LED 14,8V 4S 3200mAh 40C | 14.8V 4S 40C 3200mAh LiPo EC3 LED |
| DYNC3005 | Passport Duo 400W Dual AC/DC Touch Charger | Passport Duo 400 W Duales Wechsel-/ Gleichstrom-Ladegerät | Chargeur Passport Duo 400W AC/DC, écran tactile | Caricabatteria AC/DC Passport Duo Touch 400 W |
| KXSC1004 | KX50D Duo 2 x 50W AC/DC Charger | KX50D Duo 2 x 50 W Wechsel-/ Gleichstrom-Ladegerät | Chargeur KX50D Duo 2 x 50W AS/DC | Caricabatteria AC/DC KX50D Duo 2 x 50 W |
| SPMA3081 | AS3X Programming Cable - Audio Interface | Spektrum Audio-Interface AS3X Empfänger Programmierkabel | Câble de programmation audio AS3X pour smartphone | Cavo di programmazione AS3X - Interfaccia audio |
| SPMA3065 | AS3X Programming Cable - USB Interface | Spektrum USB-Interface AS3X Empfänger Programmierkabel | Câble de programmation USB AS3X pour PC | Cavo di programmazione AS3X - Interfaccia USB |
| EFLA111 | Li-Po Cell Voltage Checker | Li-Po Cell Voltage Checker | Testeur de tension d'éléments Li-Po | Voltmetro verifica batterie LiPo |
| DYN1405 | Li-Po Charge Protection Bag, Large | Dynamite LiPoCharge Protection Bag groß | Sac de charge Li-Po, grand modèle | Sacchetto grande di protezione per carica LiPo |
| DYN1400 | Li-Po Charge Protection Bag, Small | Dynamite LiPoCharge Protection Bag klein | Sac de charge Li-Po, petit modèle | Sacchetto piccolo di protezione per carica LiPo |
| | DXe DSMX 6-Channel Transmitter | Spektrum DXe DSMX 6-Kanal Sender | Emetteur DXe DSMX 6 voies | DXe DSMX Trasmettitore 6 canali |
| | DX6eDSMX 6-Channel Transmitter | Spektrum DX6e DSMX 6-Kanal Sender | Emetteur DX6e DSMX 6 voies | DX6e DSMX Trasmettitore 6 canali |
| | DX6 DSMX 6-Channel Transmitter | Spektrum DX6 DSMX 6-Kanal Sender | Emetteur DX6 DSMX 6 voies | DX6 DSMX Trasmettitore 6 canali |
| | DX7G2 DSMX 7-Channel Transmitter | Spektrum DX7 DSMX 7 Kanal Sender | Emetteur DX7 DSMX 7 voies | DX7 DSMX Trasmettitore 7 canali |
| | DX8e DSMX 8-Channel Transmitter | Spektrum DX8e DSMX 8 Kanal Sender | Emetteur DX8e DSMX 8 voies | DX8e DSMX Trasmettitore 8 canali |
| | DX8G2 DSMX 8-Channel Transmitter | Spektrum DX8G2 DSMX 8 Kanal Sender | Emetteur DX8G2 DSMX 8 voies | DX8G2 DSMX Trasmettitore 8 canali |
| | DX9 DSMX 9-Channel Transmitter | Spektrum DX9 DSMX 9 Kanal Sender | Emetteur DX9 DSMX 9 voies | DX9 DSMX Trasmettitore 9 canali |
| | DX18 DSMX 18-Channel Transmitter | Spektrum DX18 DSMX 18 Kanal Sender | Emetteur DX18 DSMX 18 voies | DX18 DSMX Trasmettitore 18 canali |
| | DX20 DSMX 20-Channel Transmitter | Spektrum DX20 DSMX 20 Kanal Sender | Emetteur DX20 DSMX 20 voies | DX20 DSMX Trasmettitore 20 canali |
| | iX12 DSMX 12-Channel Transmitter | Spektrum iX12 DSMX 12 Kanal Sender | Emetteur iX12 DSMX 12 voies | iX12 DSMX Trasmettitore 12 canali |



Extra 300 1.m

© 2018 Horizon Hobby, LLC.

E-flite, the E-Flite logo, DSM, DSM2, DSMX, Bind-N-Fly, BNF, the BNF logo, Plug-N-Play, AS3X, SAFE, the SAFE logo, ModelMatch, Passport, Prophet, EC3, and the Horizon Hobby logo are trademarks or registered trademarks of Horizon Hobby, LLC.

The Spektrum trademark is used with permission of Bachmann Industries, Inc.

Futaba is a registered trademark of Futaba Denshi Kogyo Kabushiki Kaisha Corporation of Japan.

All other trademarks, service marks and logos are property of their respective owners.

US 8,672,726. US 9,056,667. Other patents pending.

<http://www.e-fliterc.com/>