

RTR
READY-TO-RUN

BAJAREY®

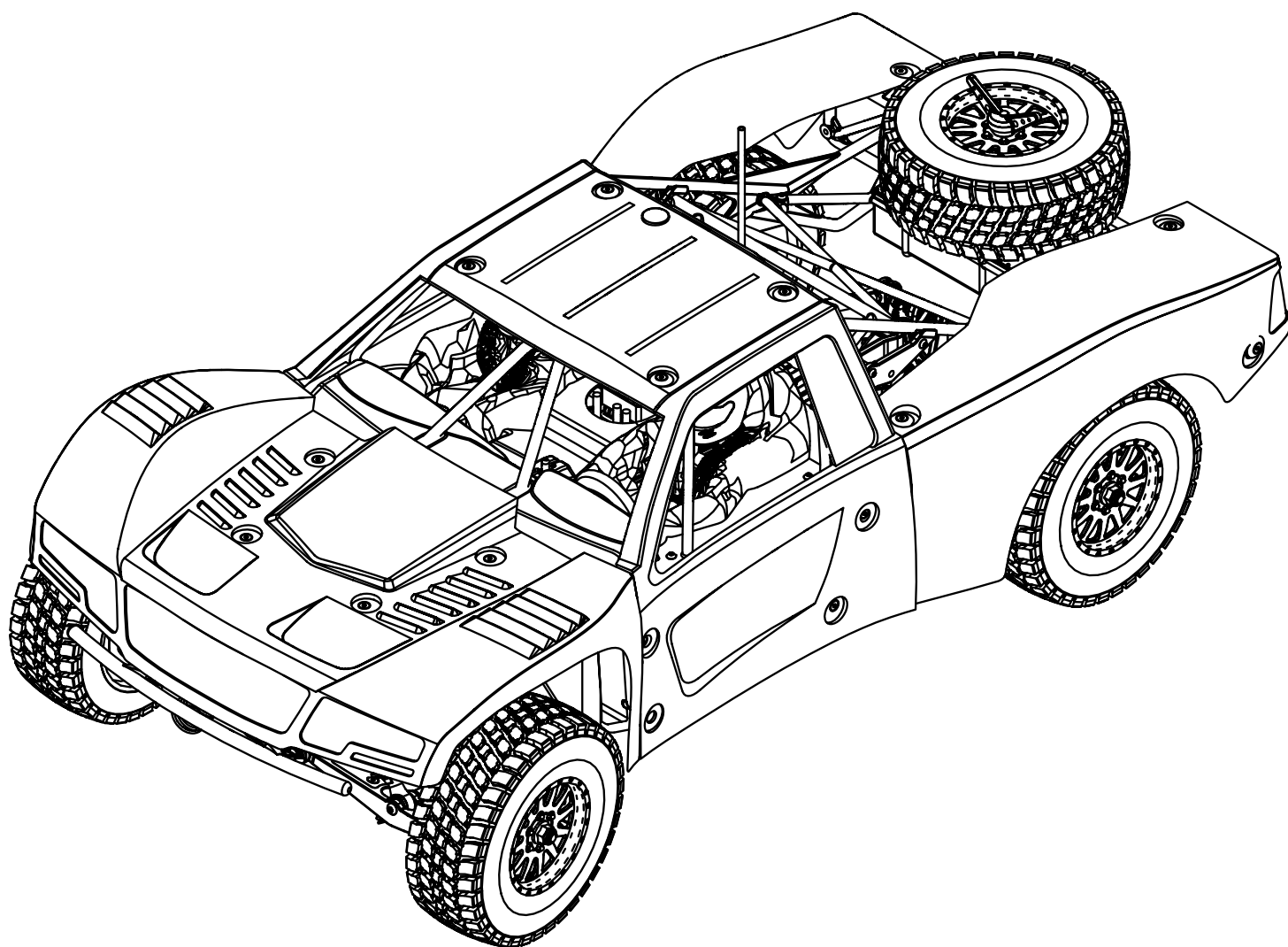

AVC® U.S. Pat. No. 9,320,977

**INSTRUCTION MANUAL
BEDIENUNGSANLEITUNG
MANUEL D'UTILISATION
MANUALE DI ISTRUZIONI**



Before operating this vehicle, please read all printed materials thoroughly.
Horizon Hobby is not responsible for inadvertent errors in this manual.

NOTICE

All instructions, warranties and other collateral documents are subject to change at the sole discretion of Horizon Hobby, LLC. For up-to-date product literature, visit horizonhobby.com and click on the support tab for this product.

MEANING OF SPECIAL LANGUAGE

The following terms are used throughout the product literature to indicate various levels of potential harm when operating this product:

NOTICE: Procedures, which if not properly followed, create a possibility of physical property damage AND a little or no possibility of injury.

CAUTION: Procedures, which if not properly followed, create the probability of physical property damage AND a possibility of serious injury.

WARNING: Procedures, which if not properly followed, create the probability of property damage, collateral damage, and serious injury OR create a high probability of superficial injury.

WARNING: Read the ENTIRE instruction manual to become familiar with the features of the product before operating. Failure to operate the product correctly can result in damage to the product, personal property and cause serious injury.

This is a sophisticated hobby product. It must be operated with caution and common sense and requires some basic mechanical ability. Failure to operate this Product in a safe and responsible manner could result in injury or damage to the product or other property. This product is not intended for use by children without direct adult supervision. Do not use with incompatible components or alter this product in any way outside of the instructions provided by Horizon Hobby, LLC. This manual contains instructions for safety, operation and maintenance. It is essential to read and follow all the instructions and warnings in the manual, prior to assembly, setup or use, in order to operate correctly and avoid damage or serious injury.

WARNING AGAINST COUNTERFEIT PRODUCTS Always purchase from a Horizon Hobby, LLC authorized dealer to ensure authentic high-quality Spektrum product. Horizon Hobby, LLC disclaims all support and warranty with regards, but not limited to, compatibility and performance of counterfeit products or products claiming compatibility with DSM or Spektrum technology.

Age Recommendation: Not for children under 14 years. This is not a toy.

SAFETY PRECAUTIONS AND WARNINGS

As the user of this product, you are solely responsible for operating in a manner that does not endanger yourself and others or result in damage to the product or property of others.

This model is controlled by a radio signal subject to interference from many sources outside your control. This interference can cause momentary loss of control, so it is advisable to always keep a safe distance in all directions around your model as this margin will help avoid collisions or injury.

- Never operate your model with low transmitter batteries.
- Always operate your model in open spaces away from full-size vehicles, traffic and people.
- Never operate the model in the street or in populated areas for any reason.
- Carefully follow the directions and warnings for this and any optional support equipment (chargers, rechargeable battery packs, etc.) you use.
- Keep all chemicals, small parts and anything electrical out of the reach of children.

- Never lick or place any portion of the model in your mouth as it could cause serious injury or even death.
- Exercise caution when using tools and sharp instruments.
- Take care during maintenance as some parts may have sharp edges.
- Immediately after using your model, do NOT touch equipment such as the motor, electronic speed control and battery, because they generate high temperatures. You may burn yourself seriously touching them.
- Do not put fingers or any objects inside rotating and moving parts, as this may cause damage or serious injury.
- Always turn on your transmitter before you turn on the receiver in the car. Always turn off the receiver before turning your transmitter off.
- Keep the wheels of the model off the ground when checking the operation of the radio equipment.

TABLE OF CONTENTS

CONTENTS	2
WATER-RESISTANT VEHICLE WITH WATERPROOF ELECTRONICS	3
QUICK START	3
CHARGING THE BATTERY	3
INSTALLING THE BATTERY	4
SPEKTRUM DX2E RADIO SYSTEM	4
SRS4220 AVC TECHNOLOGY RECEIVER	4
INSTALLING THE TRANSMITTER BATTERIES	4
STABILITY ASSIST RECEIVER	5
DRIVING PRECAUTIONS	5
POWERING ON THE VEHICLE	5
BEFORE RUNNING YOUR VEHICLE	5
AVC SENSITIVITY	5
DISABLING AVC	6
PERFORMING A CONTROL DIRECTION TEST	6
RUN TIME	6
CHANING THE TRAVEL ADJUST SETTINGS	6
DYNAMITE FUZE 130A SENSORLESS BRUSHLESS ESC	6
DYNAMITE FUZE 3800KV BRUSHLESS MOTOR	8
TROUBLESHOOTING GUIDE	8
LIMITED WARRANTY	9
FCC INFORMATION	10
IC INFORMATION	10
WARRANTY AND SERVICE CONTACT INFORMATION	10
COMPLIANCE INFORMATION FOR THE EUROPEAN UNION	10
REPLACEMENT PARTS	35–36
OPTIONAL PARTS	36–37
EXPLODED VIEWS	37–41

CONTENTS

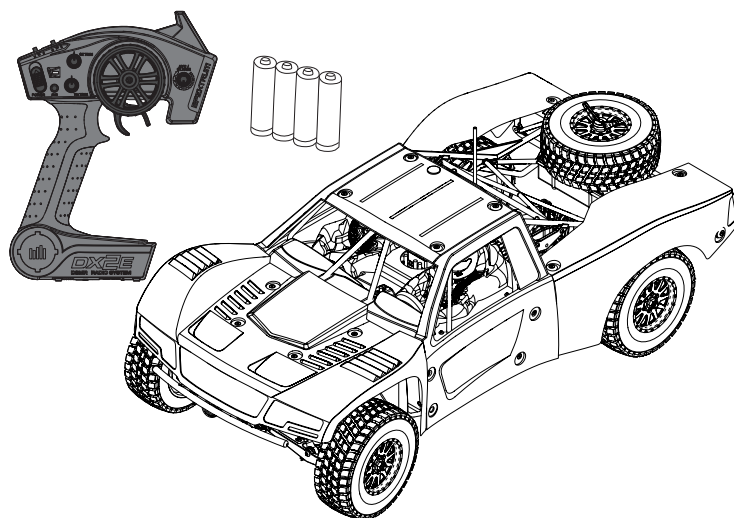

REGISTER YOUR LOSI PRODUCT ONLINE

Register your vehicle now and be the first to find out about the latest option parts, product updates and more. Click on the Support tab at WWW.LOSI.COM and follow the product registration link to stay connected.

COMPONENTS

- Losi® Baja Rey® RTR with AVC® technology: 1/10-Scale 4WD Desert Truck (LOS03008)
- Spektrum™ DX2E 2.4GHz Transmitter (SPM2330)
- Spektrum™ 4-Channel DSMR® AVC Surface Receiver (SPMSRS4220)
- Spektrum™ 9KG 23T Waterproof Servo (SPMS605)
- Dynamite® Fuze™ 130A Sensorless Brushless Waterproof ESC (DYN4955)
- Dynamite® Fuze™ 550 Brushless Motor 3800Kv (DYN51616)
- 4 AA batteries (for transmitter)

WATER-RESISTANT VEHICLE WITH WATERPROOF ELECTRONICS

Your new Horizon Hobby vehicle has been designed and built with a combination of waterproof and water-resistant components to allow you to operate the product in many “wet conditions,” including puddles, creeks, wet grass, snow and even rain.

While the entire vehicle is highly water-resistant, it is not completely waterproof and your vehicle should NOT be treated like a submarine. The various electronic components used in the vehicle, such as the Electronic Speed Control (ESC), servo(s) and receiver are waterproof, however, most of the mechanical components are water-resistant and should not be submerged.

Metal parts, including the bearings, hinge pins, screws and nuts, as well as the contacts in the electrical cables, will be susceptible to corrosion if additional maintenance is not performed after running in wet conditions. To maximize the long-term performance of your vehicle and to keep the warranty intact, the procedures described in the “Wet Conditions Maintenance” section below must be performed regularly if you choose to run in wet conditions. If you are not willing to perform the additional care and maintenance required, then you should not operate the vehicle in those conditions.

 **CAUTION:** Failure to exercise caution while using this product and complying with the following precautions could result in product malfunction and/or void the warranty.

GENERAL PRECAUTIONS

- Read through the wet conditions maintenance procedures and make sure that you have all the tools you will need to properly maintain your vehicle.
- Not all batteries can be used in wet conditions. Consult the battery manufacturer before use. Caution should be taken when using Li-Po batteries in wet conditions.
- Most transmitters are not water-resistant. Consult your transmitter’s manual or the manufacturer before operation.
- Never operate your transmitter or vehicle where lightning may be present.
- Do not operate your vehicle where it could come in contact with salt water (ocean water or water on salt-covered roads), contaminated or polluted water. Salt water is very conductive and highly corrosive, so use caution.
- Even minimal water contact can reduce the life of your motor if it has not been certified as water-resistant or waterproof. If the motor becomes excessively wet, apply very light throttle until the water is mostly removed from the motor. Running a wet motor at high speeds may rapidly damage the motor.

- Driving in wet conditions can reduce the life of the motor. The additional resistance of operating in water causes excess strain. Alter the gear ratio by using a smaller pinion or larger spur gear. This will increase torque (and motor life) when running in mud, deeper puddles, or any wet conditions that will increase the load on the motor for an extended period of time.

WET CONDITIONS MAINTENANCE

- Drain any water that has collected in the tires by spinning them at high speed. With the body removed, place the vehicle upside down and pull full throttle for a few short bursts until the water has been removed.

 **CAUTION:** Always keep hands, fingers, tools and any loose or hanging objects away from rotating parts when performing the above drying technique.

- Remove the battery pack(s) and dry the contacts. If you have an air compressor or a can of compressed air, blow out any water that may be inside the recessed connector housing.
- Remove the tires/wheels from the vehicle and gently rinse the mud and dirt off with a garden hose. Avoid rinsing the bearings and transmission.

NOTICE: Never use a pressure washer to clean your vehicle.

- Use an air compressor or a can of compressed air to dry the vehicle and help remove any water that may have gotten into small crevices or corners.
- Spray the bearings, drive train, fasteners and other metal parts with a water-displacing light oil. Do not spray the motor.
- Let the vehicle air dry before you store it. Water (and oil) may continue to drip for a few hours.
- Increase the frequency of disassembly, inspection and lubrication of the following:
 - Front and rear axle hub assembly bearings.
 - All transmission cases, gears and differentials.
 - Motor—clean with an aerosol motor cleaner and re-oil the bushings with lightweight motor oil.

QUICK START

Please read the entire manual to gain a full understanding of the Baja Rey vehicle, fine-tuning the setup and performing maintenance.

1. Read the safety precautions found in this manual.
2. Charge a battery for the vehicle. Refer to the included charging warnings and instructions for battery charging information.
3. Install the AA batteries in the transmitter. Only use alkaline or rechargeable batteries.
4. Install the fully charged battery in the vehicle.
5. Power ON the transmitter and then the vehicle. Wait 5 seconds for the ESC to initialize. Always power the transmitter ON before the vehicle and power it OFF after the vehicle has been powered OFF.
6. Check the steering and throttle control directions. Verify that the servos are moving in the correct direction.
7. Drive your vehicle.
8. Perform any necessary maintenance.

CHARGING THE BATTERY

Choose a battery designed to work with the Dynamite® Fuze™ 130A Sensorless BL Waterproof ESC. We recommend the Dynamite® 7.4 5000mAh 2S 30C LiPo: Hardcase with EC3™ connector (DYN9005EC). Choose a charger designed to charge 2S Li-Po

batteries. We recommend the Dynamite® Prophet™ Sport Li-Po 35W AC Battery Charger (DYNC2005CA). Refer to your battery and charger manuals for usage, safety, and charging information.

INSTALLING THE BATTERY

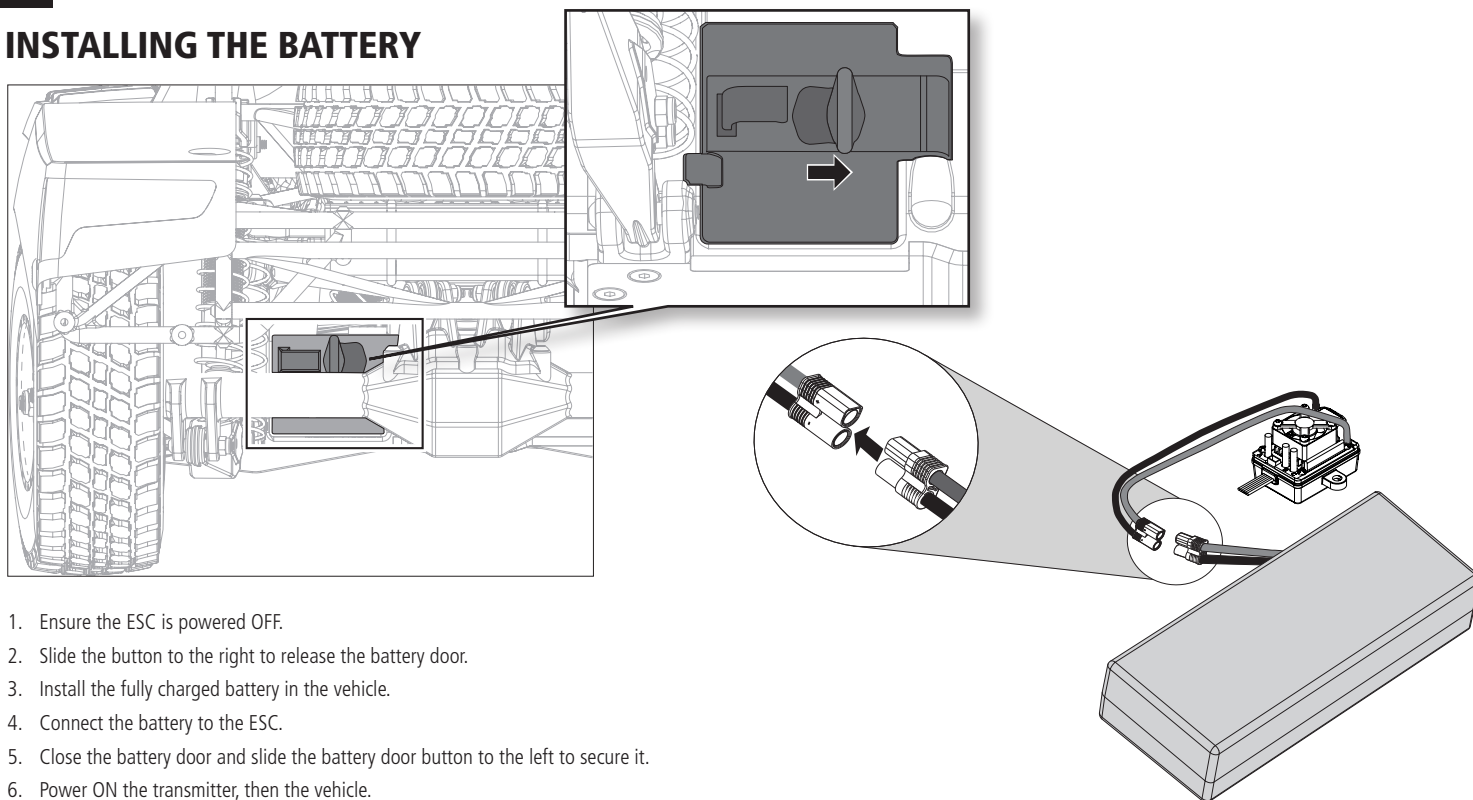

1. Ensure the ESC is powered OFF.
2. Slide the button to the right to release the battery door.
3. Install the fully charged battery in the vehicle.
4. Connect the battery to the ESC.
5. Close the battery door and slide the battery door button to the left to secure it.
6. Power ON the transmitter, then the vehicle.

SPEKTRUM DX2E RADIO SYSTEM

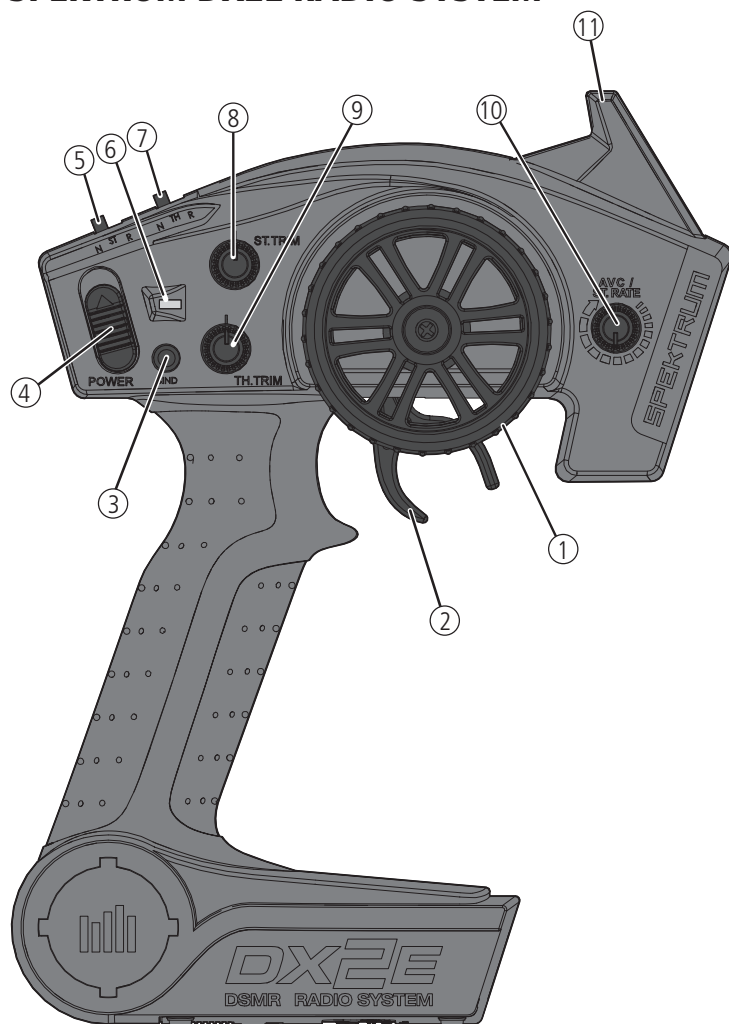

1. **Steering Wheel** Controls direction (left/right) of the model
2. **Throttle Trigger** Controls speed and direction (forward/brake/reverse) of the model
3. **BIND Button** Puts the transmitter into Bind Mode
4. **ON/OFF Switch** Turns the power ON/OFF for the transmitter
5. **ST. REV** Reverses the function of the steering when the wheel is turned left or right
6. **Indicator Lights**
 - Solid green light—indicates adequate battery power
 - Flashing green light—indicates the battery voltage is critically low. Replace batteries
7. **TH. REV** Reverses the function of the speed control when pulled back or pushed forward
8. **ST Trim** Adjusts the steering center point
9. **TH Trim** Adjusts the throttle neutral point
10. **ST Rate** Adjusts the sensitivity of AVC
11. **Antenna** Transmits the signal to the model

SRS4220 AVC TECHNOLOGY RECEIVER

12. BIND
13. DISABLE
14. AUX 2
15. AUX 1
16. THR
17. STR

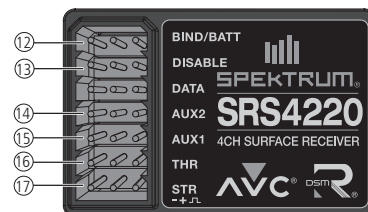

INSTALLING THE TRANSMITTER BATTERIES

1. Push in the battery cover a small amount to release the retaining tab, then remove the cover.
2. Install 4 AA batteries, taking care to align the battery polarity to the diagram in the transmitter's battery case.
3. Carefully reinstall the battery cover by aligning the tabs with the slots on the transmitter.

CAUTION: If using rechargeable batteries, charge only rechargeable batteries. Charging non-rechargeable batteries may cause the batteries to burst, resulting in injury to persons and/or damage to property.

CAUTION: Risk of explosion if battery is replaced by an incorrect type. Dispose of used batteries according to national regulations.

For more information on the transmitter, go to www.horizonhobby.com and click on the support tab for the Spektrum DX2E to download the instruction manual.

STABILITY ASSIST RECEIVER

AVC® – ACTIVE VEHICLE CONTROL™

The Spektrum receiver features Active Vehicle Control™ (AVC®) technology that responds similar to traction control in full-scale vehicles. In addition to traction control, AVC technology also increases steering stability during high speed driving or while driving over rough terrain. As you increase the AVC sensitivity, the system increases steering stability and traction control, similar to reducing the amount of steering rate in a computer transmitter. Reducing the sensitivity value increases the amount of steering control from the transmitter. The receiver also enables you to quickly turn AVC on or off if you participate in organized racing.

IMPORTANT: You must use digital servos with the AVC receiver. Do not use analog servos as they will reduce the performance of the system and may cause overheating.

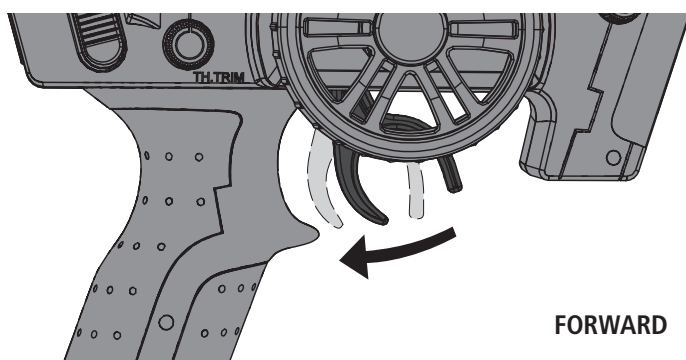

CALIBRATING THE RECEIVER

1. With the vehicle on a flat, level surface, insert the Bind Plug in the BIND port on the receiver.
2. Connect a fully charged battery pack to the ESC.
3. Power on the ESC. The orange LED flashes, indicating the receiver is in bind mode.
4. Center the ST TRIM and TH TRIM dials on the transmitter.
5. Press and hold the BIND button while powering on the transmitter.
6. Release the BIND button when the orange LED slowly flashes. The transmitter and receiver are linked when the orange LED is solid.
7. Pull the transmitter trigger to Full Throttle.
8. Push the transmitter trigger to Full Brake, then return the trigger to center.
9. Turn the transmitter steering wheel to Full Right.
10. Turn the transmitter steering wheel to Full Left, then return the steering wheel to center. The orange LED flashes once.
11. Remove the Bind Plug, then power off the receiver to save the settings.
12. Power off the transmitter.

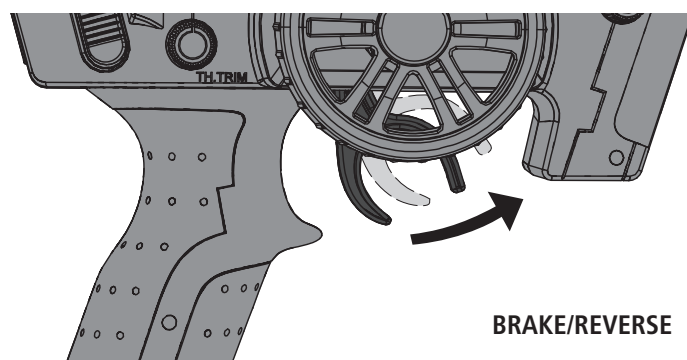

DRIVING PRECAUTIONS

- Maintain sight of the vehicle at all times.
- Routinely inspect the vehicle for loose wheel hardware.
- Routinely inspect the steering assembly for any loose hardware. Driving the vehicle off-road can cause fasteners to loosen over time.
- Do not drive the vehicle in tall grass. Doing so can damage the vehicle or electronics.
- Stop driving the vehicle when you notice a lack of power. Driving the vehicle when the battery is discharged can cause the receiver to power off. If the receiver loses power, you will lose control of the vehicle. Damage due to an over-discharged Li-Po battery is not covered under warranty.

CAUTION: Do not discharge a Li-Po battery below 3V per cell. Batteries discharged to a voltage lower than the lowest approved voltage may become damaged, resulting in loss of performance and potential fire when batteries are charged.

- Do not apply forward or reverse throttle if the vehicle is stuck. Applying throttle in this instance can damage the motor or ESC.
- After driving the vehicle, allow the electronics to cool before driving the vehicle again.

IMPORTANT: Keep wires away from all moving parts.

POWERING ON THE VEHICLE

1. Center the ST TRIM and TH TRIM dials on the transmitter.
2. Power on the transmitter.
3. Remove the body from the vehicle.
4. Connect a fully charged battery pack to the ESC.
5. Power on the ESC.

IMPORTANT: The vehicle MUST remain on a flat, level surface and motionless for at least 5 seconds.

BEFORE RUNNING YOUR VEHICLE

1. Check for free suspension movement. All suspension arms and steering components should move freely. Any binds will cause the vehicle to handle poorly.
2. Charge a battery pack. Always charge the battery pack as per the battery and/or charger manufacturers' instructions.
3. Set the transmitter steering trim. Follow the instructions to set the steering trim/subtrim so that the vehicle drives straight with no input to the steering.
4. Perform a Control Direction Test.

AVC® SENSITIVITY

The ST RATE dial adjusts the sensitivity, or stability, value in the receiver. If you increase the sensitivity, the AVC® system becomes more sensitive to the vehicle drifting left or right. You would use maximum sensitivity during high speed driving or drag racing, when you want the vehicle to stay in a straight line. As the sensitivity value increases, the amount of steering travel decreases.

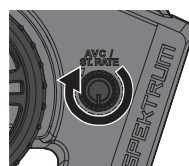

Turn the ST RATE knob counter-clockwise to reduce the sensitivity.

Turn the ST RATE knob clockwise to increase the sensitivity.

IMPORTANT: The ST RATE knob will only adjust the sensitivity when the transmitter is bound to a DSMR® receiver. When the transmitter is bound to a DSM®, DSM2® or DSM Marine receiver, the ST RATE knob controls the steering dual rate.

DISABLING AVC® TECHNOLOGY

If you participate in organized racing, you may be required to turn AVC off. To turn AVC off:

1. Insert a Bind Plug in the BIND port on the receiver.
2. Insert a second Bind Plug in the DISABLE port on the receiver.
3. Connect a fully charged battery pack to the ESC.
4. Power on the ESC. The orange LED flashes, indicating the receiver is in bind mode.
5. Center the ST TRIM and TH TRIM dials on the transmitter.
6. Press and hold the BIND button while powering on the transmitter.
7. Release the BIND button when the orange LED slowly flashes. The transmitter and receiver are linked when the orange LED is solid.
8. Pull the transmitter trigger to Full Throttle.
9. Push the transmitter trigger to Full Brake, then return the trigger to center.
10. Turn the transmitter steering wheel to Full Right.
11. Turn the transmitter steering wheel to Full Left, then return the steering wheel to center. The orange LED flashes once.
12. Remove the Bind Plugs, then power off the receiver to save the settings. The receiver will continuously blink to indicate AVC is disabled.
13. Power off the transmitter.

IMPORTANT: You must calibrate the receiver each time it is placed in bind mode. To activate AVC, see the steps in "Calibrating the Receiver."

RUN TIME

The largest factor in run time is the capacity of the battery pack. A larger mAh rating increases the amount of run time experienced.

The condition of a battery pack is also an important factor in both run time and speed. The battery connectors may become hot during driving. Batteries will lose performance and capacity over time.

Driving the vehicle from a stop to full speed repeatedly will damage the batteries and electronics over time. Sudden acceleration will also lead to shorter run times.

TO IMPROVE RUN TIMES

- Keep your vehicle clean and well maintained.
- Allow more airflow to the ESC and motor.
- Change the gearing to a lower ratio. A lower ratio decreases the operating temperature of the electronics. Use a smaller pinion gear or larger spur gear to lower the gear ratio.
- Use a battery pack with a higher mAh rating.
- Use the optimum charger to charge battery packs (Visit your local hobby dealer for more information).

DYNAMITE® FUZE™ 130A SENSORLESS BRUSHLESS ESC

SPECIFICATIONS

Type	Sensorless
Constant/Peak	130A/760A
Resistance	0.0004 Ohm
Function	Forward/Brake–Forward/Brake Reverse
Operation	Proportional forward, proportional reverse with braking delay
Input Voltage	7.4V–14.8V (The motor in this vehicle will not support 14.8V.)
BEC Output	6V/3A
Overload Protection	Thermal
Dimensions (LxWxH)	53.5mm x 36mm x 36mm
Weight	79 g

ESC LED STATUS

- No ESC LEDs will glow when there is no throttle input from the transmitter.
- The red ESC LED glows when there is any throttle input from the transmitter.

AUDIBLE WARNING TONES

1. **Input Voltage:** The ESC checks the input voltage when it is powered ON. If a voltage problem is detected, the ESC continuously sounds 2 beeps with a 1 second pause (xx-xx-xx). Power OFF the ESC and ensure the connections are secure and that the battery power is not too low for safe operation.
2. **Radio Connection:** The ESC checks radio signal input when it is powered ON. If a problem is detected, the ESC continuously sounds 1 beep with a 2 second pause (x--x--x). Power OFF the ESC and ensure the radio system is operating correctly.

PERFORMING A CONTROL DIRECTION TEST

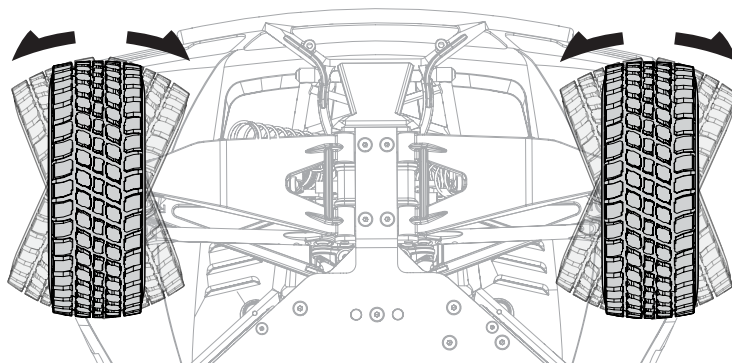

Perform a control test with the vehicle wheels off the ground. If the wheels rotate after the vehicle is powered ON, adjust the TH Trim knob until they stop. To make the wheels move forward, pull the trigger. To reverse them, wait for the wheels to stop, then push the trigger. When moving forward, the wheels should maintain a straight line without any steering wheel input. If not, adjust the ST Trim knob, so the wheels maintain a straight line without having to turn the steering wheel.

CHANGING THE TRAVEL ADJUST SETTINGS

1. Hold the trigger in the full brake position and turn the steering wheel to Full Right while powering on the transmitter. The LED flashes rapidly, indicating the programming mode is active.
2. Throttle End Point: Continue holding full throttle. Turn the TH TRIM knob to adjust the full throttle end point.
3. Brake End Point: Hold the trigger in the full brake position. Turn the TH TRIM knob to adjust the full brake end point. Return the trigger to the center position.
4. Left Steering End Point: Hold the steering wheel in the full left position. Turn the ST TRIM knob to adjust the left end point.
5. Right Steering End Point: Hold the steering wheel in the full right position. Turn the ST TRIM knob to adjust the right end point. Return the steering wheel to the center position.
6. Power off the transmitter to save the travel adjust settings. The minimum Travel is 75%, and the Maximum travel is 150%.

IMPORTANT: If the travel is changed on the DX2E, you must rebind and calibrate the receiver.

For sensorless brushless motors:

1. Connect the ESC terminal A (typically designated by a blue wire) to the motor's terminal A (red wire on a Dynamite® Fuze™ sensorless motor). This may also be changed in Programming Item 12, Motor Rotation, without changing wire connections.
2. Connect the ESC terminal B (typically designated by a yellow wire) to the motor's terminal B (blue wire on a Dynamite® Fuze™ sensorless motor).
3. Connect the ESC terminal C (typically designated by an orange wire) to the motor's terminal C (black wire on a Dynamite® Fuze™ sensorless motor).

NOTICE: Always disconnect the battery from the ESC when you have finished operating your vehicle. The ESC's switch only controls power to the receiver and servos. The ESC will continue to draw current when connected to the battery, resulting in possible damage to the battery through over discharge.

ESC CALIBRATION PROCEDURE

Ensure proper ESC function by calibrating the ESC to your transmitter inputs.

1. Power OFF the ESC.
2. Ensure your transmitter is powered ON, the throttle is not reversed, the throttle trim is neutral and the throttle travel range is at 100%. Disable any special functions such as ABS, etc.
3. Press the SET button while powering ON the ESC. Release the button as soon as the red LED starts to flash.
4. Calibrate the throttle points by pressing the SET button once after each step.
 - Neutral (1 flash)—leave the throttle at rest, untouched
 - Full throttle (2 flashes)—pull the throttle fully back
 - Full brake/reverse (3 flashes)—push the throttle fully forward
5. The motor will run 3 seconds after the last step is completed.

Tip: If the motor turns in the wrong direction, reverse the connection of any 2 outside motor wires. The center wire must remain in the center and cannot be moved to another motor tab.

ESC FUNCTIONS AND MODES

The ESC includes programming options so you can adjust the way your vehicle performs. Refer to the included settings table to adjust the ESC for your driving conditions.

ESC PROGRAMMING PROCEDURE

Programming is accomplished using the SET button on the ON/OFF switch or Digital Program Box (DYN3005).

1. Connect a fully charged battery to the ESC.
2. Power ON the ESC using the ESC switch.
3. Hold the SET button for 1 second until the green LED blinks, then release the SET button to enter programming mode.

4. Press and release the SET button as needed to get to the desired menu option (the Green LED will blink corresponding to the menu item number). Programming menu items 1 through 9 are accessible using the SET button on the ESC. Programming menu items 10 and above are only accessible using the optional ESC programming card. Programming of menu items 10 and 11 is only possible after firmware updates to the ESC programming card.
5. When at the desired menu item, hold the SET button for 3 seconds until the red LED blinks.
6. Press the SET button to move among the settings based on how many times the red LED blinks (Refer to the table for more information).
7. Save the setting by holding the SET button for 3 seconds.
8. Power OFF the ESC switch and repeat the instructions above to change other settings.

Tip: If desired, the ESC programming can be returned to default settings by powering ON the ESC and holding the SET button for 5 seconds.

PROGRAMMABLE ITEMS Basic Items	PROGRAMMABLE VALUE									Default Settings
	1	2	3	4	5	6	7	8	9	
1 Running Mode	Forward w/ brake	Forward/Reverse w/ brake	Forward/Reverse							
2 Drag Brake Force	0%	5%	10%	20%	40%	60%	80%	100%		
3 Low Voltage Cutoff	non-protection	2.6V/Cell	2.8V/Cell	3.0V/Cell	3.2V/Cell	3.4V/Cell				
4 Start Mode	Level 1	Level 2	Level 3	Level 4	Level 5	Level 6	Level 7	Level 8	Level 9	

PROGRAMMABLE ITEMS Advanced Items	PROGRAMMABLE VALUE									Default Settings
	1	2	3	4	5	6	7	8	9	
5 Max Brake Force	25%	50%	75%	100%	disable					
6 Max Reverse Force	25%	50%	75%	100%						
7 Initial Brake Force	= Drag Brake Force	0%	20%	40%						
8 Neutral Range	6% (Narrow)	9% (Normal)	12% (Wide)							
9 Timing	0.00°	3.75°	7.50°	11.25°	15.00°	18.75°	22.50°	26.25°		
10 Reserved Item										
11 Reserved Item										
12 Motor Rotation	Counterclockwise	Clockwise								
13 Li-Po Cells	Auto Calculate	2 Cells	3 Cells	4 Cells	5 Cells	6 Cells				

DESCRIPTIONS

1. Running Mode

- *Forward Only with Brake*
Intended for competition use, this mode allows only forward and brake controls.
- *Forward/Reverse with Brake*
This mode is the basic all-around mode, allowing forward, reverse and brake controls. To engage reverse while moving forward, apply the brake until the vehicle has come to a complete stop, release brake, then apply the brake again. While braking or in reverse, engaging the throttle will result in the vehicle immediately accelerating forward.

2. Drag Brake Force

Adjusts the amount of brake automatically applied when the throttle is returned to the neutral position. This simulates the engine braking effect of a full-scale vehicle, allowing improved turn-in and your vehicle's general response to controls.

3. Low Voltage Cutoff

This function helps to prevent battery over-discharge. The ESC continuously monitors the battery's voltage. If the voltage falls below the voltage threshold for 2 seconds, the output power shuts off and the red LED flashes twice repeatedly.

The cutoff threshold calculation is based on individual Li-Po cell voltage. For Ni-MH batteries, if the voltage battery pack is higher than 9.0V, it will be treated as a 3-cell Li-Po battery pack; if it is lower than 9.0V, it will be treated as a 2-cell Li-Po battery pack. Example: for a 8.0V Ni-MH battery pack used with a 2.6V/cell threshold, it will be treated as a 2-cell Li-Po battery pack and the low-voltage cut-off threshold will be 5.2V (2.6x2=5.2).

4. Start Mode (Punch)

Sets the initial throttle punch when the car accelerates. Level 1 gives a very soft initial acceleration and level 4 gives a stronger initial acceleration.

5. Max Brake Force

Adjusts the maximum braking force. A higher value provides stronger braking, but can also cause the wheels to lock, resulting in loss of control of the car.

6. Max Reverse Force

This parameter adjusts the maximum power when travelling in reverse.

7. Initial Brake Force (minimum brake)

Adjusts the minimum amount of braking power when the brakes engage. The default value is equal to the drag brake value. A high value can lock the wheels when the brake is used.

8. Neutral Range

Adjusts the throttle sensitivity around the neutral point. A higher value results in the throttle having to be moved more for the vehicle to move forward, backward or brake.

9. Timing

Adjusts the motor drive current timing. More timing gives more performance, but can lower efficiency and cause damage to the motor and/or ESC by overload or overheating.

NOTICE: Always ensure the motor timing is set correctly. Failure to set the motor timing correctly can result in damage to the motor and ESC. Refer to the manufacturer instructions for recommended timing settings.

The Following Programmable Items require the optional Digital ESC Program Box:

10. and 11. Available Items are subject to firmware updates to the ESC and the optional digital program box.

12. Motor Rotation

Allows you to make this change in the ESC so no wires need to be changed between the ESC and the motor.

13. Li-Po Cells

Allows the ESC to automatically detect or manually set the number of cells in your Li-Po battery back.

DYNAMITE® FUZE™ 3800KV BRUSHLESS MOTOR

PRECAUTIONS

- Never touch moving parts.
- Never disassemble while the batteries are installed.
- Always let parts cool before touching.

GEARING

Your vehicle has been equipped with the optimal gearing for the stock platform. It offers an ideal balance between speed, power and efficiency. Should you decide to customize your vehicle with optional batteries or motors, it may be necessary for you to change the pinion or spur gear.

Installing a pinion gear with fewer teeth or a spur gear with more teeth will provide greater torque but will reduce top speed. Likewise, a pinion gear with more teeth or a spur gear with fewer teeth will reduce torque and increase top speed. Care should be taken when installing larger pinion gears as this can "overgear" the vehicle, resulting in overheating of the motor and ESC. When testing different gearing options, pay close attention to the temperature of the motor and speed control to ensure you are operating within the temperature range of the components. The motor or ESC should never be so hot that it cannot be touched. If temperatures are too hot, a different gearing combination with a lower pinion gear and/or higher spur gear is suggested.

TROUBLESHOOTING GUIDE

PROBLEM	POSSIBLE CAUSE	SOLUTION
Vehicle does not operate	Battery not charged or plugged in	Charge battery/plug in
	ESC switch not "On"	Turn on ESC switch
	Transmitter not "On" or low battery	Turn on/replace batteries
Motor runs but wheels do not rotate	Pinion not meshing with spur gear	Adjust pinion/spur mesh
	Pinion spinning on motor shaft	Tighten pinion gear setscrew on motor shaft flat spot
	Transmission gears stripped	Replace transmission gears
	Drive pin broken	Check and replace drive pin
Steering does not work	Servo plug not in receiver properly	Make sure the steering servo plug is connected to the receiver steering channel, noting proper polarity
	Servo gears or motor damaged	Replace or repair servo
Will not turn one direction	Servo gears damaged	Replace or repair servo
Motor does not run	Motor wire solder joint is damaged	Resolder the motor wire with the proper equipment
	Motor wire broken	Repair or replace as needed
	ESC damaged	Contact Horizon Hobby Product Support
ESC gets hot	Motor over-gearred	Use smaller pinion or larger spur gear
	Driveline bound up	Check wheels and transmission for binding
Poor run time and/or sluggish acceleration	Battery pack not fully charged	Recharge battery
	Charger not allowing full charge	Try another charger
	Driveline bound up	Check wheels, transmission for binding
Poor range and/or glitching	Transmitter batteries low	Check and replace
	Vehicle battery low	Recharge battery
	Loose plugs or wires	Check all wire connections and plugs

LIMITED WARRANTY

What this Warranty Covers

Horizon Hobby, LLC, (Horizon) warrants to the original purchaser that the product purchased (the "Product") will be free from defects in materials and workmanship at the date of purchase.

What is Not Covered

This warranty is not transferable and does not cover (i) cosmetic damage, (ii) damage due to acts of God, accident, misuse, abuse, negligence, commercial use, or due to improper use, installation, operation or maintenance, (iii) modification of or to any part of the Product, (iv) attempted service by anyone other than a Horizon Hobby authorized service center, (v) Product not purchased from an authorized Horizon dealer, or (vi) Product not compliant with applicable technical regulations or (vii) use that violates any applicable laws, rules, or regulations.

OTHER THAN THE EXPRESS WARRANTY ABOVE, HORIZON MAKES NO OTHER WARRANTY OR REPRESENTATION, AND HEREBY DISCLAIMS ANY AND ALL IMPLIED WARRANTIES, INCLUDING, WITHOUT LIMITATION, THE IMPLIED WARRANTIES OF NON-INFRINGEMENT, MERCHANTABILITY AND FITNESS FOR A PARTICULAR PURPOSE. THE PURCHASER ACKNOWLEDGES THAT THEY ALONE HAVE DETERMINED THAT THE PRODUCT WILL SUITABLY MEET THE REQUIREMENTS OF THE PURCHASER'S INTENDED USE.

Purchaser's Remedy

Horizon's sole obligation and purchaser's sole and exclusive remedy shall be that Horizon will, at its option, either (i) service, or (ii) replace, any Product determined by Horizon to be defective. Horizon reserves the right to inspect any and all Product(s) involved in a warranty claim. Service or replacement decisions are at the sole discretion of Horizon. Proof of purchase is required for all warranty claims. SERVICE OR REPLACEMENT AS PROVIDED UNDER THIS WARRANTY IS THE PURCHASER'S SOLE AND EXCLUSIVE REMEDY.

Limitation of Liability

HORIZON SHALL NOT BE LIABLE FOR SPECIAL, INDIRECT, INCIDENTAL OR CONSEQUENTIAL DAMAGES, LOSS OF PROFITS OR PRODUCTION OR COMMERCIAL LOSS IN ANY WAY, REGARDLESS OF WHETHER SUCH CLAIM IS BASED IN CONTRACT, WARRANTY, TORT, NEGLIGENCE, STRICT LIABILITY OR ANY OTHER THEORY OF LIABILITY, EVEN IF HORIZON HAS BEEN ADVISED OF THE POSSIBILITY OF SUCH DAMAGES. Further, in no event shall the liability of Horizon exceed the individual price of the Product on which liability is asserted. As Horizon has no control over use, setup, final assembly, modification or misuse, no liability shall be assumed nor accepted for any resulting damage or injury. By the act of use, setup or assembly, the user accepts all resulting liability. If you as the purchaser or user are not prepared to accept the liability associated with the use of the Product, purchaser is advised to return the Product immediately in new and unused condition to the place of purchase.

Law

These terms are governed by Illinois law (without regard to conflict of law principals). This warranty gives you specific legal rights, and you may also have other rights which vary from state to state. Horizon reserves the right to change or modify this warranty at any time without notice.

WARRANTY SERVICES

Questions, Assistance, and Services

Your local hobby store and/or place of purchase cannot provide warranty support or service. Once assembly, setup or use of the Product has been started, you must contact your local

distributor or Horizon directly. This will enable Horizon to better answer your questions and service you in the event that you may need any assistance. For questions or assistance, please visit our website at www.horizonhobby.com, submit a Product Support Inquiry, or call the toll free telephone number referenced in the Warranty and Service Contact Information section to speak with a Product Support representative.

Inspection or Services

If this Product needs to be inspected or serviced and is compliant in the country you live and use the Product in, please use the Horizon Online Service Request submission process found on our website or call Horizon to obtain a Return Merchandise Authorization (RMA) number. Pack the Product securely using a shipping carton. Please note that original boxes may be included, but are not designed to withstand the rigors of shipping without additional protection. Ship via a carrier that provides tracking and insurance for lost or damaged parcels, as Horizon is not responsible for merchandise until it arrives and is accepted at our facility. An Online Service Request is available at http://www.horizonhobby.com/content/_service-center_render-service-center. If you do not have internet access, please contact Horizon Product Support to obtain a RMA number along with instructions for submitting your product for service. When calling Horizon, you will be asked to provide your complete name, street address, email address and phone number where you can be reached during business hours. When sending product into Horizon, please include your RMA number, a list of the included items, and a brief summary of the problem. A copy of your original sales receipt must be included for warranty consideration. Be sure your name, address, and RMA number are clearly written on the outside of the shipping carton.

NOTICE: Do not ship Li-Po batteries to Horizon. If you have any issue with a Li-Po battery, please contact the appropriate Horizon Product Support office.

Warranty Requirements

For Warranty consideration, you must include your original sales receipt verifying the proof-of-purchase date. Provided warranty conditions have been met, your Product will be serviced or replaced free of charge. Service or replacement decisions are at the sole discretion of Horizon.

Non-Warranty Service

Should your service not be covered by warranty, service will be completed and payment will be required without notification or estimate of the expense unless the expense exceeds 50% of the retail purchase cost. By submitting the item for service you are agreeing to payment of the service without notification. Service estimates are available upon request. You must include this request with your item submitted for service. Non-warranty service estimates will be billed a minimum of ½ hour of labor. In addition you will be billed for return freight. Horizon accepts money orders and cashier's checks, as well as Visa, MasterCard, American Express, and Discover cards. By submitting any item to Horizon for service, you are agreeing to Horizon's Terms and Conditions found on our website http://www.horizonhobby.com/content/_service-center_render-service-center.

ATTENTION: Horizon service is limited to Product compliant in the country of use and ownership. If received, a non-compliant Product will not be serviced. Further, the sender will be responsible for arranging return shipment of the un-serviced Product, through a carrier of the sender's choice and at the sender's expense. Horizon will hold non-compliant Product for a period of 60 days from notification, after which it will be discarded.

Warranty and Service Contact Information

Country of Purchase	Horizon Hobby	Contact Information	Address
United States of America	Horizon Service Center (Repairs and Repair Requests)	servicecenter.horizonhobby.com/RequestForm/	4105 Filedstone Rd. Champaign, Illinois 61822 USA
	Horizon Product Support (Product Technical Assistance)	productsupport@horizonhobby.com 877-504-0233	
	Sales	websales@horizonhobby.com 800-338-4639	
EU	Horizon Technischer Service	service@horizonhobby.eu	Hanskampring 9 D 22885 Barsbüttel, Germany
	Sales: Horizon Hobby GmbH	+49 (0) 4121 2655 100	

FCC Statement

FCC ID: BRWDSTX1 BRWDASRX12 This device complies with part 15 of the FCC rules. Operation is subject to the following two conditions: (1) This device may not cause harmful interference, and (2) this device must accept any interference received, including interference that may cause undesired operation.



CAUTION: Changes or modifications not expressly approved by the party responsible for compliance could void the user's authority to operate the equipment.

This product contains a radio transmitter with wireless technology which has been tested and found to be compliant with the applicable regulations governing a radio transmitter in the 2.400GHz to 2.4835GHz frequency range.

IC Information

IC: 6157A-STX1 6157 A-AMRX12 This device complies with Industry Canada licence-exempt RSS standard(s). Operation is subject to the following two conditions: (1) this device may not cause interference, and (2) this device must accept any interference, including interference that may cause undesired operation of the device.

CE EU Compliance Statement: Horizon Hobby, LLC hereby declares that this product is in compliance with the essential requirements and other relevant provisions of the R&TTE, RED and EMC Directive.

A copy of the EU Declaration of Conformity is available online at:
<http://www.horizonhobby.com/content/support-render-compliance>.



Instructions for disposal of WEEE by users in the European Union

This product must not be disposed of with other waste. Instead, it is the user's responsibility to dispose of their waste equipment by handing it over to a designated collections point for the recycling of waste electrical and electronic equipment. The separate collection and recycling of your waste equipment at the time of disposal will help to conserve natural resources and ensure that it is recycled in a manner that protects human health and the environment. For more information about where you can drop off your waste equipment for recycling, please contact your local city office, your household waste disposal service or where you purchased the product.

Replacement Parts // Teileliste // Liste des pièces de rechange // Elenco dei ricambi

Part #	English	Deutsch	Français	Italiano
DYN4955	Fuze 130A Sensorless Brushless WP ESC	Fuze 130A Sensorless Brushless ESC spritzwassergeschützt	Contrôleur Fuze Brushless 130A étanche	ESC brushless waterproof Fuze 130 A senza sensori
DYNS1616	Fuze 550BL Motor, 3800Kv	Fuze 550BL Motor, 3800Kv	Moteur Fuze Brushless 550, 3800Kv	Motore brushless Fuze 550, 3800 Kv
LOSA3573	1.0 Module Pitch Pinion, 13T	Ritzel Modul 1, 13T	Pignon modulaire 1.0, 13 dents	Pignone a passo modulare 1.0, 13 denti
LOSA6250	Set Screws, 4mm & 5mm (6 ea)	Madenschrauben 4 & 5 mm (je 6)	Vis, 4mm et 5mm (6 chacun)	Grani, 4 mm e 5 mm (6 cad.)
LOSA6937	5x10mm Sealed Ball Bearing (2)	Kugellager, gekapselt 5 x10mm	Roulements à billes scellés 5x10mm (2)	Cuscinetto a sfere sigillato 5x10 mm (2)
LOSA6940	6x12mm Sealed Ball Bearing (4)	Kugellager, gekapselt 6 x12mm (4)	Roulements à billes scellés 6x12mm (4)	Cuscinetto a sfere sigillato 6x12 mm (4)
LOSA6956	12x18x4mm Sealed Ball Bearing (2)	Kugellager gekapselt 12 x18x 4mm	Roulements à billes scellés 12x18x4mm (2)	Cuscinetto a sfere sigillato 12x18x4 mm (2)
LOSA6957	10x 15x4mm Bearing	Kugellager 5 x 10 x 4mm (2)	Roulements 5 x 10 x 4mm (2)	10x15x4mm Cuscinetti 5 x 10 x 4mm (2)
LOSB3008	3x6x2.5mm Ball Bearing (2)	Kugellager, 3x6x2.5mm (2)	Roulements à billes 3x6x2.5mm (2)	Cuscinetto a sfere 3x6x2,5 mm (2)
LOS230010	Roll Cage Sides L&R: Baja Rey	Überrollbügelteile links und rechts: Baja Rey	Baja Rey - Faces latérales gauche et droite de l'arceau cage	Parti laterali roll cage D&S: Baja Rey
LOS230011	Top Bar, X-Bar,Cover & Tire Mount: Baja Rey	Obere Abdeckung, X-Abdeckung: Baja Rey	Baja Rey - Barre supérieure, Barre X, protection et support pneu	Barra superiore, barra a X, copertura e supporto gomma: Baja Rey
LOS230012	Fr Bar, RR Body Mnt Bar, Bumper, Tower Support: Baja Rey	Karosserieteile hinten Stoßfänger: Baja Rey	Baja Rey - Barre avant, barre de support de carrosserie arrière, support	Barra ant., barra supporto carrozz. post., paraurto, montante torretta: Baja Rey
LOS230013	Body Button Base & Top (22): Baja Rey	Body Button Base & Top (22): Baja Rey	Baja Rey - Anneaux de protection de carrosserie (22)	Body Button Base & Top (22): Baja Rey
LOS230020	Interior Set with Helmets, Clear: Baja Rey	Interiorset mit Helmen, transparent: Baja Rey	Baja Rey - Décoration intérieure avec casques, transparente	Set interni con caschi, trasparente: Baja Rey
LOS230026	Sticker Sheet: Baja Rey	Sticker Bogen: Baja Rey	Feuille d'autocollants: Baja Rey	Adesivi: Baja Rey
LOS231005	Rear Bulkhead,Fan Panel, Mudguards: Baja Rey	Lüfterpanel, Schmutzfänger: Baja Rey	Baja Rey - Cloison arrière, ventilateur et bavettes	Paratia post., fan panel, parafango: Baja Rey
LOS231006	Battery Tray,Door, Lock, 2S Spacer: Baja Rey	Akkuhalter und Klappe, 2S Distanzstück: Baja Rey	Baja Rey - Support batterie, trappe, verrou et cales 2S	Vano batteria, portello, chiusura, distanziale 2S: Baja Rey
LOS231007	Front Upper Arm/Shock Mount, RR Chassis Brace: Baja Rey	Stoßdämpferbefestigung hinten mit Chassishalter: Baja Rey	Baja Rey - Triangle supérieur/fixation d'amortisseur avant, renfort arrière de châssis	Braccetto superiore ant. / supporto ammortizz., trapezio post.: Baja Rey
LOS231008	Servo Mount, Steering Servo Set Plastic: Baja Rey	Servohalter: Baja Rey	Baja Rey - Support servo, servo de direction plastique	Supporto servo, set servo sterzo in plastica: Baja Rey
LOS231010	Chassis Plate & Motor Cover Plate: Baja Rey	Chassisplatte und Motorabdeckung: Baja Rey	Baja Rey - Platine de châssis et couvercle moteur	Piastra telaio & piastra copertura motore: Baja Rey
LOS231011	Center Chassis Brace & Standoffs: Baja Rey	Chassishalter und Distanzstücke: Baja Rey	Baja Rey - Renfort central de châssis et entretoises	Montanti telaio centrali con distanziali: Baja Rey
LOS231012	Motor Mount: Baja Rey	Motorhalter: Baja Rey	Baja Rey - Support moteur	Supporto motore: Baja Rey
LOS231013	Steering Hardware Set: Baja Rey	Zubehörsset Lenkung: Baja Rey	Baja Rey - Set d'accessoires de direction	Set hardware sterzo: Baja Rey
LOS232001	Axle Housing Set; Rear: Baja Rey	Achsgehäuse set hinten: Baja Rey	Baja Rey - Carter de pont arrière	Set alloggiamento asse posteriore: Baja Rey
LOS232002	Center Transmission Housing: Baja Rey	Achsgehäuse mitte: Baja Rey	Baja Rey - Boîtier de transmission centrale	Scatola trasmissione centrale: Baja Rey
LOS232003	Front Gear Box/Bulkhead: Baja Rey	Getriebegehäuse mit Halter: Baja Rey	Baja Rey - Set de carters de transmission avant/Cellule	Scatola ingranaggio anteriore / paratia: Baja Rey
LOS232004	HD Diff Housing & Internals: Baja Rey	Differentialgehäuse mit Einsätzen: Baja Rey	Baja Rey - Corps de différentiel renforcé et éléments internes	Scatola diff. HD ed parti interne: Baja Rey
LOS232005	Rear Driveshaft Set: Baja Rey	Antriebswelle hinten: Baja Rey	Baja Rey - Tiges de cardans arrière	Set trasmissione posteriore: Baja Rey
LOS232006	Hex, Rotor, Caliper & Pin Set (4): Baja Rey	Scheibenbremse mit Bremssattel Vorne/Hinten: Baja Rey	Baja Rey - Hexagone, rotor, mâchoires et goupilles	Set esagone, rotore, spessore e perno: Baja Rey
LOS232007	Center Transmission Gear Set: Baja Rey	Getriebe set Mitte: Baja Rey	Baja Rey - Set de pignons de transmission centrale	Set ingranaggio trasmissione centrale: Baja Rey
LOS232008	40T Ring & 14T Pinion Gear FR/RR: Baja Rey	Stirnrad 40 Zähne & 14 er Ritzel: Baja Rey	Baja Rey - Anneau 40T et Pignon 14T avant/arrière	40T ingranaggio & 14T pignone ant./post.: Baja Rey
LOS232009	Front Axle Set (2): Baja Rey	Vorderachsenset (2): Baja Rey	Baja Rey - Axe de roues avant (2)	Set asse anteriore: Baja Rey
LOS232010	Center Drive Shaft: Baja Rey	Antriebswelle Mitte: Baja Rey	Baja Rey - Cardan central	Albero di trasmissione centrale: Baja Rey
LOS232011	Rear Diff Locker: Baja Rey	Differentialsperre hinten: Baja Rey	Baja Rey - Verrou de diff arrière	Diff. locker posteriore: Baja Rey
LOS232012	Center Outdrive Set: Baja Rey	Antriebsklaue mitte: Baja Rey	Baja Rey - Set de noix de cardans centraux	Set trascintore centrale: Baja Rey
LOS232013	Front Outdrive Set: Baja Rey	Antriebsklaue vorne: Baja Rey	Baja Rey - Set de noix de cardans avant	Set trascintore anteriore: Baja Rey
LOS232014	Rear Axle Shaft Set: Baja Rey	Hinterachswellenset: Baja Rey	Baja Rey - Axe de roues arrière	Set semiasse posteriore: Baja Rey
LOS233001	Shock Ends, Tops, Piston: Baja Rey	Stoßdämpferendeteile, Kolben: Baja Rey	Baja Rey - Chapes d'amortisseurs, bouchons supérieurs et pistons	Terminali, tappi, pistoni ammortizz.: Baja Rey
LOS233002	FR/RR Shock Body & Collar Set: Baja Rey	Stoßdämpfergehäuse, Distanzringe v/h: Baja Rey	Baja Rey - Corps d'amortisseurs avant/arrière avec bague	Corpo ammortizz. ant./post & collarino
LOS233003	FR/RR Shock Shaft Set & Hardware: Baja Rey	Dämpfer Kolbenstange mit Zubehör: Baja Rey	Baja Rey - Tiges d'amortisseurs avant/arrière avec visserie	Stelo ammortizz. ant./post e hardware: Baja Rey
LOS233004	FR/RR Shock Seal & Limiter Set: Baja Rey	Stoßdämpferdichtung und Begrenzer: Baja Rey	Baja Rey - Joint d'amortisseurs avant/arrière avec limiteur	Set guarnizione ammortizz. ant./post. e limitatore: Baja Rey
LOS233005	Front and Rear Spring Set: Baja Rey	Dämpferfedern v/h: Baja Rey	Baja Rey - Ressort avant/arrière	Set molle ant./post.: Baja Rey
LOS234002	Shock Tower, Upper/Track Rod Mounts, Rear: BR	Dämpferbrücke hinten: Baja Rey	Baja Rey - Support d'amortisseurs, tirants	Torretta ammortizz., supporti tirante sterzo superiore post.: Baja Rey
LOS234003	Trailing Arm, Steering, Upper, Drag Link St: BR	Lenkgestänge: Baja Rey	Baja Rey - Tringlerie de direction supérieure	Braccetto longitudinale, sterzo, superiore, tirante sterzo: Baja Rey
LOS234004	Front Suspension Arm Set Upper/Lower: Baja Rey	Querlenkerker set unten: Baja Rey	Baja Rey - Bras de suspension avant supérieur et inférieur	Set braccetti sospensione ant. inferiore/ superiore: Baja Rey
LOS234005	Steering Spindle Set & Hardware: Baja Rey	Lenkspindelset: Baja Rey	Baja Rey - Set de fusées et visserie	Set fusello sterzo e hardware:
LOS234006	Front & Rear Sway Bar Links: Baja Rey	Querlenkerverbinder vorne: Baja Rey	Baja Rey - Tringlerie barre anti-roulis avant/arrière	Collegamenti barra antitorzione ant./post.: Baja Rey
LOS234007	Front Hinge Pins & Brace Set: Baja Rey	Querlenkerstifte und Halter: Baja Rey	Baja Rey - Renfort de cellule avant	Perni braccetti ant. e set piastine

Replacement Parts // Teileliste // Liste des pièces de rechange // Elenco dei ricambi

Part #	English	Deutsch	Français	Italiano
LOS234008	7mm Steel Pivot Ball Double Boss (10): Baja Rey	7mm Kugelköpfe (10): Baja Rey	Baja Rey - Rotules Double Boss acier 7mm (10)	7mm Steel Pivot Ball Double Boss (10): Baja Rey
LOS235001	Cap Head Screws M2 x 6mm (10)	Sechskantschraube M2 x 6mm (10)	Vis CHC M2 x 6mm (10)	Viti a testa piatta M2 x 6mm (10)
LOS235002	Cap Head Screws M2.5 x 10mm (10)	Sechskantschraube M2.5 x 10mm (10)	Vis CHC M2,5 x 10mm (10)	Viti a testa piatta M2.5 x 10mm (10)
LOS235003	Cap Head Screws M3 x 6mm (10)	Sechskantschraube M3 x 6mm (10)	Vis CHC M3 x 6mm (10)	Viti a testa piatta M3 x 6mm (10)
LOS235004	Cap Head Screws M3 x 25mm (10)	Sechskantschraube M3 x 25mm (10)	Vis CHC M3 x 25mm (10)	Viti a testa piatta M3 x 25mm (10)
LOS235005	Button Head Screws M2.5x6mm (10)	Halbrundschrabe M2.5 x 6mm (10)	Vis BHC M2,5 x 6mm (10)	Viti a testa tonda M2.5x6mm (10)
LOS235006	Button Head Screws M2.5x 20mm (10)	Halbrundschrabe M2.5 x 20mm (10)	Vis BHC M2,5 x 20mm (10)	Viti a testa tonda M2.5x 20mm (10)
LOS235007	Button Head Screws M4 x 12mm (10)	Halbrundschrabe M4 x 12mm (10)	Vis BHC M4 x 12mm (10)	Viti a testa tonda M4 x 12mm (10)
LOS235008	Flat Head Screws M2.5 x 5mm (10)	Flachkopfschraube M2.5 x 5mm (10)	Vis FHC M2,5 x 5mm (10)	Viti a testa piatta M2.5 x 5mm (10)
LOS235009	Flat Head Screws M2.5 x 8mm (10)	Flachkopfschraube M2.5 x 8mm (10)	Vis FHC M2,5 x 8mm (10)	Viti a testa piatta M2.5 x 8mm (10)
LOS235010	Flat Head Screws M2.5 x 12mm (10)	Flachkopfschraube M2.5 x 12mm (10)	Vis FHC M2,5 x 12mm (10)	Viti a testa piatta M2.5 x 12mm (10)
LOS235011	Set Screws, M3 x 3mm Cup Point (10)	Madenschraube M3 x 3mm spitz (10)	Vis STHC M3 x 3mm CUV (10)	Grano, M3 x 3mm punta piana (10)
LOS235012	Set Screw, M4 x 4mm Cup Point (10)	Madenschrauben, M4 x 4mm spitz (10)	Vis STHC M4 x 4mm CUV (10)	Grano, M4 x 4mm punta piana (10)
LOS235013	Flat Nut, M3 x 0.5 x 5mm (10)	Flachmutter M3 x 05 x 5mm (10)	Écrou plat M3 x 0,5 x 5mm (10)	Dado piatto, M3 x 0.5 x 5mm (10)
LOS235014	Lock Nut, M2 x 0.4 x4mm (10)	Stopmmutter M2 x 0.4mm (10)	Écrou auto-freiné M2 x 0,4 x 4mm (10)	Dado autobloccante, M2 x 0.4 x4mm (10)
LOS235015	Lock Nut, Flanged M5 x 0.8 (10)	Stopmmutter M5 x 0.8mm geriffelt (10)	Écrou auto-freiné épaulé strié M5 x 0,8mm (10)	Dado autobloccante con flangia dentata M5 x 0.8 (10)
LOS321009	Front Bumper & Skid Plate: Baja Rey	Stoßfänger vorne und Unterfahrschutz: Baja Rey	Baja Rey - Pare choc avant et protection	Paraurto anteriore e piastra protetti telaio: Baja Rey
LOS43006	Wheels (4): Baja Rey	Räder (4): Baja Rey	Baja Rey - Roues (4)	Ruote (4): Baja Rey
LOS43011	Desert Claws Tires Soft w/Foam (2)	Desert Claws Reifen mit Schaumeinlage (2)	Pneus Desert Claws Soft avec inserts (2)	Gomme Desert Claws soft con inserti (2)
SPMS605	9KG Servo, WP, Metal Gear, 23T	Servo, spritzwassergeschützt 9Kg MG, 23T	Servo 9Kg à pignons métal, étanche, tête 23T	Servo 9 kg, waterproof, ingranaggi metallici, 23 denti
SPMSRS4220	Spektrum SR4200 DSMR AVC Surface Receiver	Spektrum SR4200 DSMR AVC Surface Empfänger	Servo 9Kg à pignons métal, étanche, tête 23T	Ricevente di superficie Spektrum SR4200 DSMR AVC
TLR5904	Button Head Screws, M3 x 0.5mm x 12mm, Stl, BZ	TLR Rundkopfschraube, M3 x 12mm (10)	Vis à tête bombée M3 x 12mm (10)	Viti testa tonda, M3 x 12mm (10)
TLR5909	Button Head Screws, M3 x 0.5mm x 16mm, Stl, BZ, Pref	TLR Rundkopfschraube, M3 x 16mm (10)	Vis à tête bombée M3 x 16mm (10)	Viti testa tonda, M3 x 16mm (10)
TLR5910	Button Head Screws, M3 x 0.5mm x 14mm, Stl, BZ	TLR Rundkopfschrauben M3 x 14mm (10)	Vis à tête bombée M3 x 14mm (10)	Viti testa tonda, M3 x 14mm (10)
TLR5911	Button Head Screws, M3 x 0.5mm x 20mm, Stl, BZ, Pref	TLR Rundkopfschrauben M3 x 20mm (10)	Vis à tête bombée M3 x 20mm (10)	Viti testa tonda, M3 x 20mm (10)
TLR5913	Button Head Screws, M2.5 x 0.45mm x 12mm, Stl, BZ	TLR Rundkopfschrauben M2.5 x 12mm (10)	Vis à tête bombée M2.5 x 12mm (10)	Viti testa tonda, M2.5 x 12mm (10)
TLR5932	Cap Head Screws, M3 x 0.5mm x 10mm, Stl, BZ, Pref	TLR Zylinderkopfschraube, M3 x 10mm (10)	Vis BTR M3 x 10mm (10)	Viti testa a brugola, M3 x 10mm (10)
TLR5933	Cap Head Screws, M3 x 12mm (10)	TLR Zylinderkopfschraube, M3 x 12mm (10)	Vis BTR M3 x 12mm (10)	Viti testa a brugola, M3 x 12mm (10)
TLR5934	Cap Head Screws, M3 x 0.5mm x 16mm, Stl, BZ, Pref	TLR Zylinderkopfschraube, M3 x 16mm (10)	Vis BTR M3 x 16mm (10)	Viti testa a brugola, M3 x 16mm (10)
TLR5935	Cap Head Screws, M3 x 0.5mm x 20mm, Stl, BZ, Pref	TLR Zylinderkopfschraube, M3 x 20mm (10)	Vis BTR M3 x 20mm (10)	Viti testa a brugola, M3 x 20mm (10)
TLR5961	Screw, M3 x 0.5mm x 8mm, Flat Head, Stl, BZ	TLR Flachkopfschrauben, M3 x 8mm (10)	Vis à tête fraisée M3 x 8mm (10)	Vite a testa piatta, M3 x 8mm (10)
TLR5963	Screw, M3 x 0.5mm x 12mm, Flat Head, Stl, BZ	TLR Flachkopfschrauben, M3 x 12mm (10)	Vis à tête fraisée M3 x 12mm (10)	Vite a testa piatta, M3 x 12mm (10)
TLR5964	Screw, M3 x 0.5mm x 16mm, Flat Head, Stl, BZ, Pref	TLR Flachkopfschrauben, M3 x 16mm (10)	Vis à tête fraisée M3 x 16mm (10)	Vite a testa piatta, M3 x 16mm (10)
TLR5965	Screw, M3 x 0.5mm x 20mm, Flat Head, Stl, BZ, Pref	TLR Flachkopfschrauben, M3 x 20mm (10)	Vis à tête fraisée M3 x 20mm (10)	Vite a testa piatta, M3 x 20mm (10)
TLR6312	Locknut, M2.5x.45 x 5mm (6)	Stopmmutter M2.5x.45 x 5mm (6)	Écrou M2,5x0,45x5mm (6)	Dado autobloccante, M2,5x45x5mm (6)
TLR6313	Nut, M3 x 0.5mm x 5.5mm, Nylock, Stl, Clear Zinc	TLR Mutter selbstsichernd, M3 x .5 x 5.5mm (10)	Écrou M3 x 0,5 x 5,5mm (10)	Dado autobloccante, M3 x .5 x 5.5mm (10)
TLR6352	Washer, 3.2mm x 7mm x 0.5mm, Stl, Clear Zinc	TLR U-Scheibe, M3 (10)	Rondelles M3 (10)	Rondelle, M3 (10)
TLR74006	Silicone Shock Oil, 30wt, 2oz.	Silikon Dämpferöl 30wt, 2oz	Huile silicone d'amortisseur, 30wt, 60 ml	Olio silconico ammortizzatori, 30 wt, 2 oz.
TLR255007	Button Head Screws M4x.07mm x 12mm (10)	TLR Rundkopfschraube, M4 x 12mm (10)	Vis à tête bombée M4 x 12mm (10)	Viti testa tonda, M4 x 12mm (10)
VTR236003	Flat Nut, M4 x 0.7 x 7mm (10)	Flachmutter M 4 x 0,7 x 7mm (10)	Écrou plat, M4 x 0,7 x 7mm (10)	Dado piatto, M4 x 0,7 x 7mm (10)
VTR236025	M4 Nylock Flanged Nut	Nylon Bundmutter M4	Écrou épaulé autofreiné M4 (10)	Dado flangiato Nylock M4
VTR246001	Screw Pin, Clip Post (10): Glamis Uno	Stiftschraube(10) GLU	Supports de clips avec goupilles (10): GLU	Perni viti clip (10): GLU

Optional Parts // Diverse Teile // Pièces optionnelles // Pezzi opzionali

Part #	English	Deutsch	Français	Italiano
LOS230009	Body Set, Clear: Baja Rey	Karosserie Set: Baja Rey	Baja Rey - Carrosserie, transparente	Set carrozzeria, trasparente: Baja Rey
LOS330001	LED Roof Light Bar Set: Baja Rey	LED Light Bar Set f. Dachmontage: Baja Rey	Baja Rey - Rampe lumineuse DEL toit	Set barra luci LED tetto: Baja Rey
LOS331001	Aluminum Steering Servo Mount: Baja Rey	Lenkervohalter Aluminium: Baja Rey	Baja Rey - Support de servo de direction aluminium	Supporto servo sterzo alluminio: Baja Rey
LOS331002	Aluminum Bellcrank Servo Saver Set: BR	Servo Saver Aluminium: aja Rey	Baja Rey - Sauve servo levier aluminium	Set salvaservo squadrette alluminio: Baja Rey
LOS331003	Adjustable Turnbuckle Set: BR/RR	Gewindestangenset einstellbar: BR/RR	BR/RR - Biellettes réglables	Set tiranti filettati regolabili: BR/RR
LOS331004	Aluminum Rear Upper Link & Space Set: Baja Rey	Heckanlenkung und Distanzstück Aluminium: Baja Rey	Baja Rey - Tirant supérieur arrière et entretoise aluminium	Set collegamenti e distanziali superiori posteriori alluminio: Baja Rey
LOS331005	Aluminum Servo Arm, 23T: Baja Rey	Servoarm Aluminium, 23T: Baja Rey	Baja Rey - Palonnier de servo aluminium, 23T	Squadretta servo alluminio, 23 denti: Baja Rey
LOS331006	Aluminum Servo Arm, 24T: Baja Rey	Servoarm, Aluminium 24T: Baja Rey	Baja Rey - Palonnier de servo aluminium, 24T	Squadretta servo alluminio, 24 denti: Baja Rey
LOS331007	Aluminum Servo Arm, 25T: Baja Rey	Servoarm Aluminium, 25T: Baja Rey	Baja Rey - Palonnier de servo aluminium, 25T	Squadretta servo alluminio, 25 denti: Baja Rey

EXPLODED VIEW
 EXPLOSIONSZEICHNUNG
 VUE ÉCLATÉE DES PIÈCES
 VISTA ESPLOSA DELLE PARTI

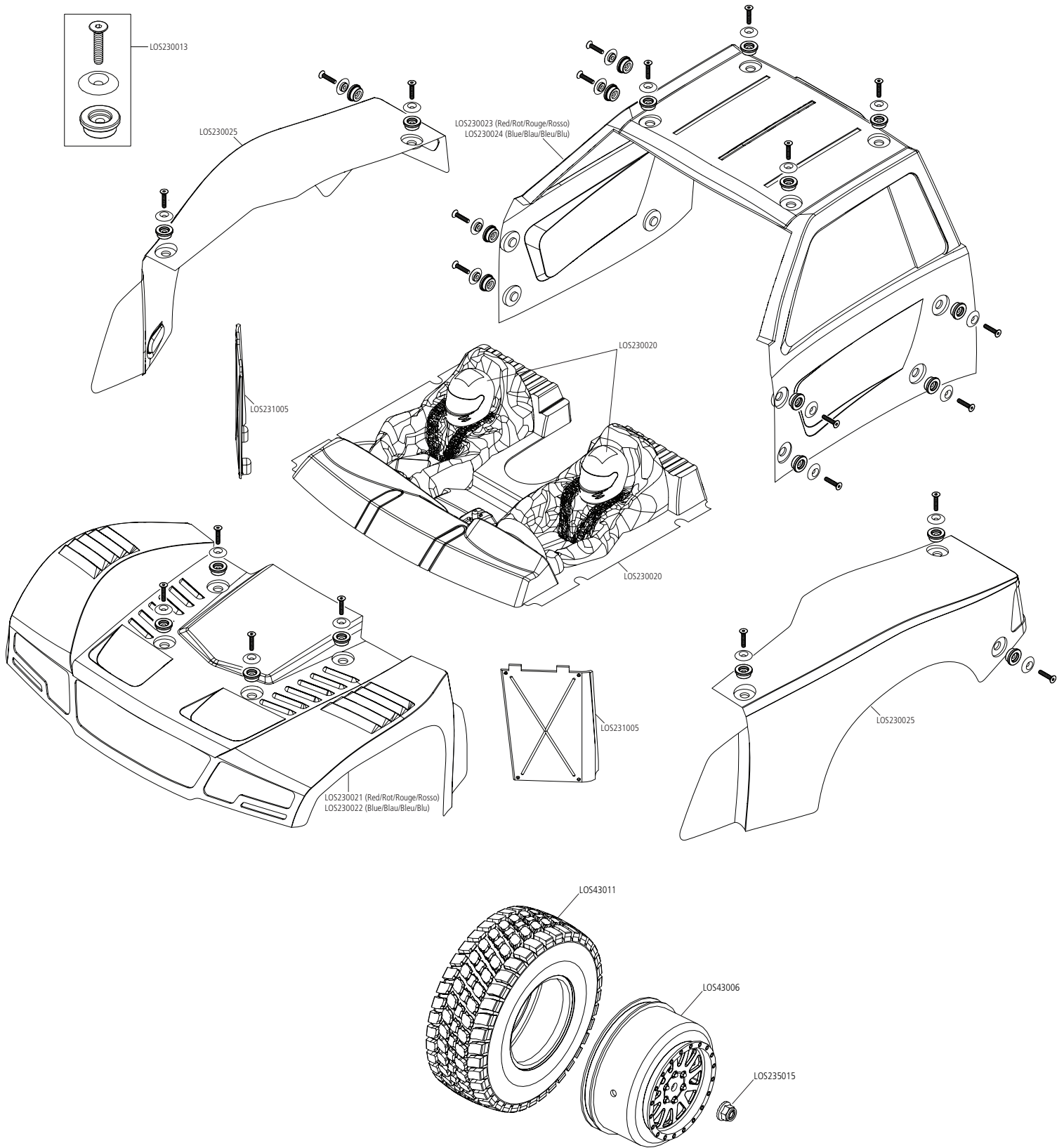

**EXPLODED VIEW
EXPLOSIONSZEICHNUNG
VUE ÉCLATÉE DES PIÈCES
VISTA ESPLOSA DELLE PARTI**

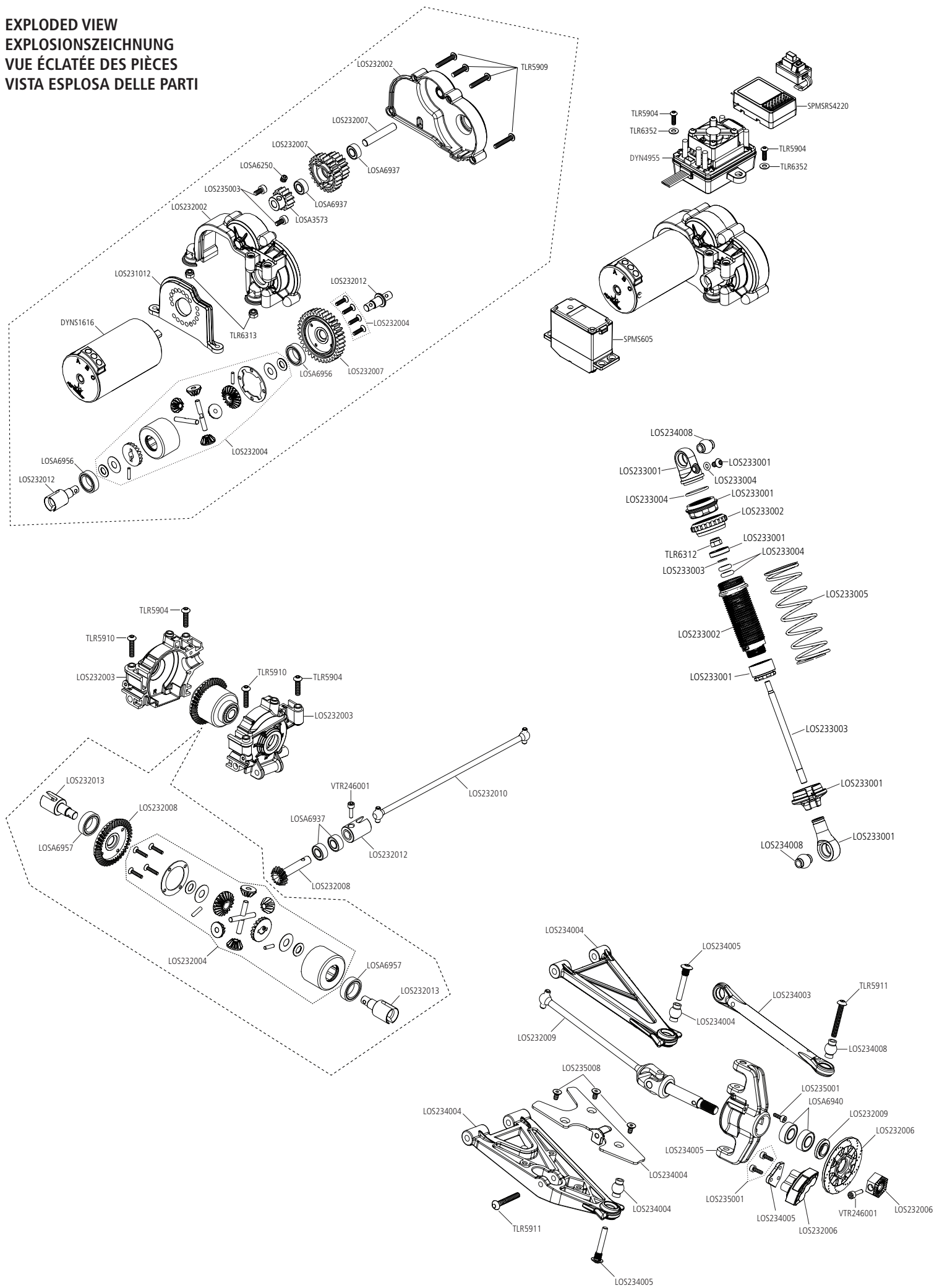



WWW.LOSI.COM

©2017 Horizon Hobby, LLC.

Losi, Baja Rey, DSM, DSM2, DSMR, AVC, Active Vehicle Control, EC3, Dynamite, Fuze, Prophet and the Horizon Hobby logo are trademarks or registered trademarks of Horizon Hobby, LLC. The Spektrum trademark is used with permission of Bachmann Industries, Inc. US 9,320,977.

Other patents pending.

Updated 03/17



44326.1 LOS03008