

PRO-LINE PRO-2

1:10 2WD SHORT COURSE TRUCK KIT



POWERSTROKE
PERFORMANCE SHOCKS

PRO-LINE
FLO-TEK

PROTRAC
SUSPENSION

PRO-2

1:10 2WD SHORT COURSE TRUCK KIT

Thank you for purchasing Pro-Line's first-ever complete kit: the PRO-2! For over 30 years, Pro-Line has designed and manufactured the best RC accessories in the world. Pro-Line has taken the best performance parts and combined them into one complete kit. Congratulations on making the right decision and joining Team Pro-Line in making history!

Included Performance Parts:

- Pro-Line Performance Transmission
- PRO-2 LCG Performance Chassis
- PowerStroke Shocks
- ProTrac Suspension Kit
- Performance Steering Kit
- Flo-Tek SC Body
- Secure-Loc Body Mount System
- Blockade M3 Pre-Mounted Tires
- Short Course Closed Cell Inserts
- F-11 ProTrac Offset Black Wheels
- Military-grade components

Enjoy your Ride!
From your friends at Pro-Line

This assembly manual contains instructions for building your new PRO-2. Please take your time building the kit according to the instructions and becoming familiar with the steps.

Pro-Line is continually improving our products; consequently, actual parts included in the PRO-2 kit may appear slightly different than the images that appear in the manual.

TOOLS REQUIRED



EQUIPMENT REQUIRED



SCAN FOR HELP



Help and Information

Installation manuals and videos can be found on our website at <http://prolineracing.com/pro-2/build>
For any help you may need, you can call our tech support line at 1-800-866-RACE(7223).

SCAN TO REGISTER



Registration

Register your kit online at <http://prolineracing.com/pro-2/register> or call 1-800-899-RACE(7223).

WARNING! This is NOT a toy and is NOT suitable for children under 14 years old. This kit contains many small parts which are potential choking hazards. Keep all components out of reach from small children.

HEALTH WARNING! This product contains chemicals known to the State of California to cause cancer, birth defects, or other reproductive harm. This kit is a high performance radio controlled model kit and can cause harm or personal injury. All liquids contained in this kit are not to be swallowed. Never touch rotating parts as this can cause injury.

HARDWARE USED
(ACTUAL SIZE)

 **x 2**
M3 x 8 SHCS

1 Front Bumper to Brace (Bag A)

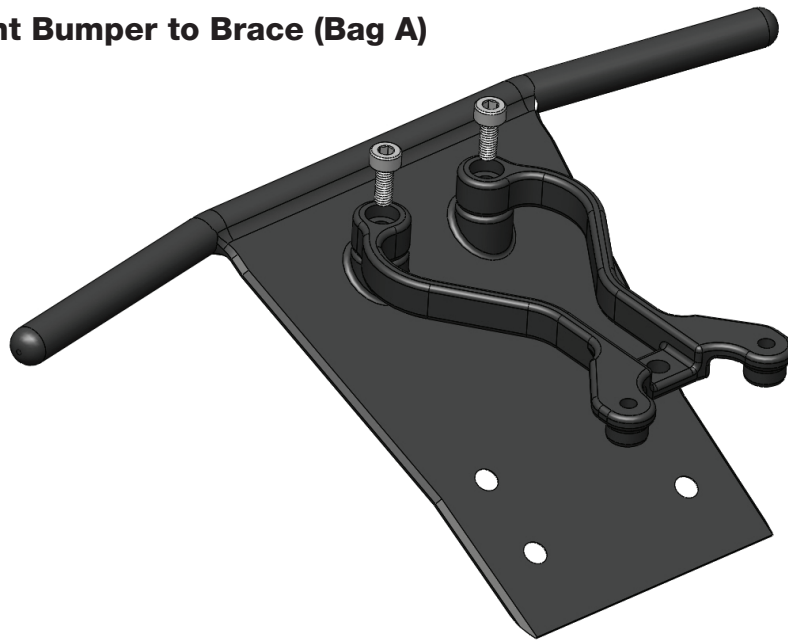

HARDWARE USED
(ACTUAL SIZE)

 **x 2**
M3 x 14 BHCS
(Bag B)

2 Front Shock Tower to Bulkhead (ProTrac Bag & Bag B)

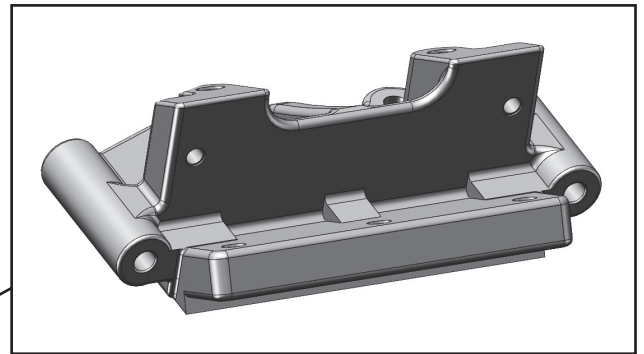
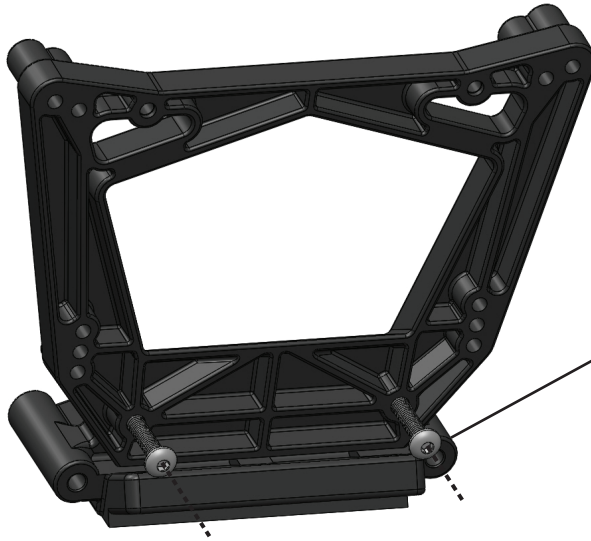

HARDWARE USED
(ACTUAL SIZE)

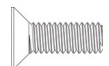
 **x 4**
M4 x 12 FHCS

3 Front Bumper to Bulkhead (Bag A)

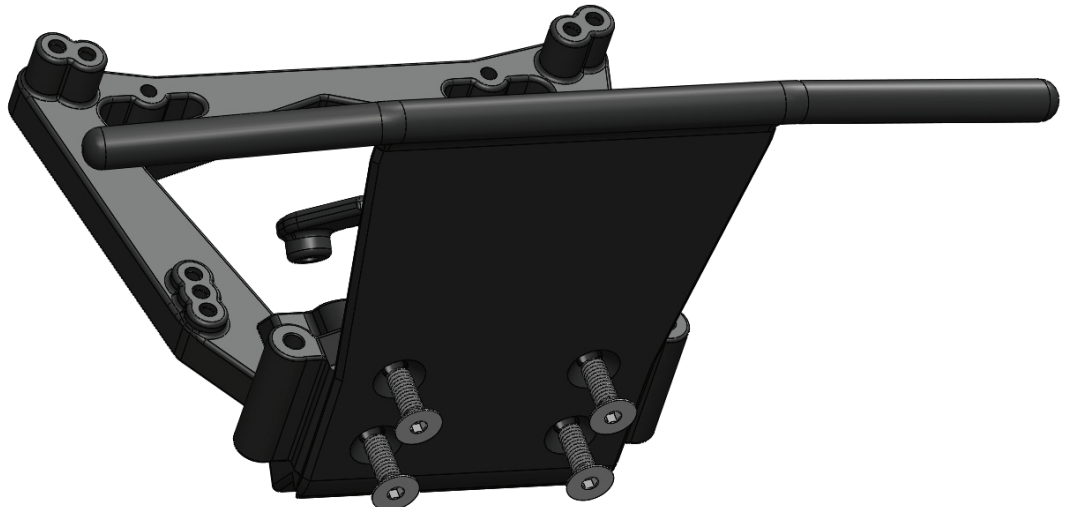

HARDWARE USED
(ACTUAL SIZE)

 **x 2**
M3 x 30 SHCS

 **x 2**
M3 Washers

 **x 2**
Ball Ends

 **x 2**
M3 Locknuts

4 Shock Mounting Hardware (Bag C)

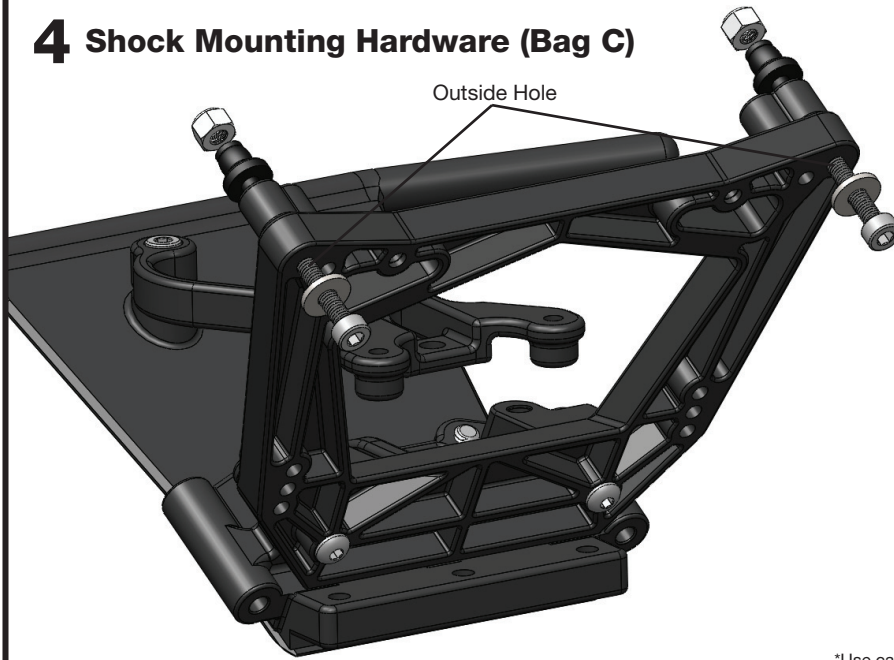

*Use caution if using power tools. Heat may melt plastic.

HARDWARE USED
(ACTUAL SIZE)

 **x 2**
M3 x 12 Low-Profile
(Bag B)

 **x 2**
M3 x 14 BHCS
(Bag D)

5 Front Body Mount to Shock Tower (Bag D & Bag B)

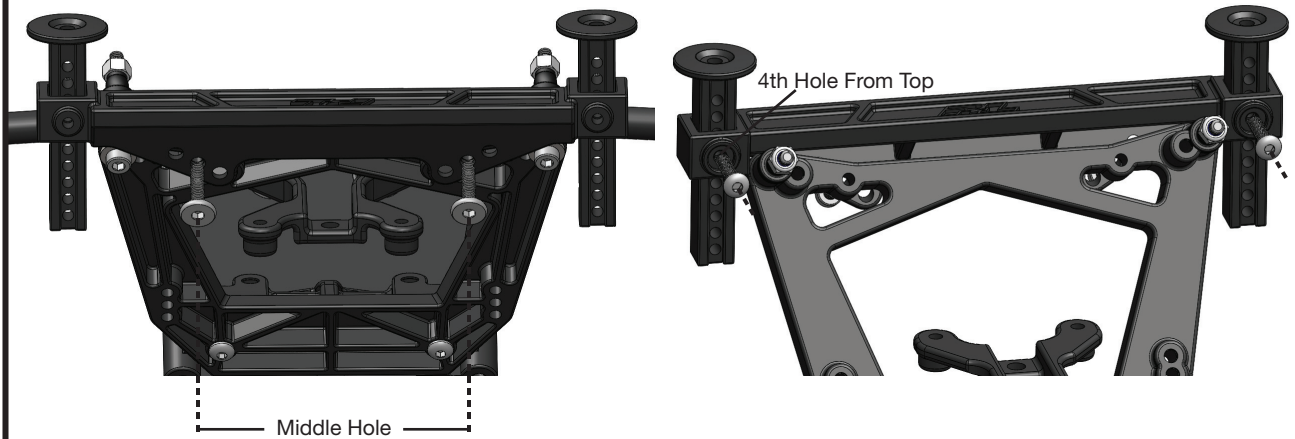

HARDWARE USED
(ACTUAL SIZE)

 **x 2**
Black O-Ring

 **x 2**
M4 x 12 Set Screw

 **x 2**
Secure-Loc Cap

6 Body Mount Hardware (Bag D)

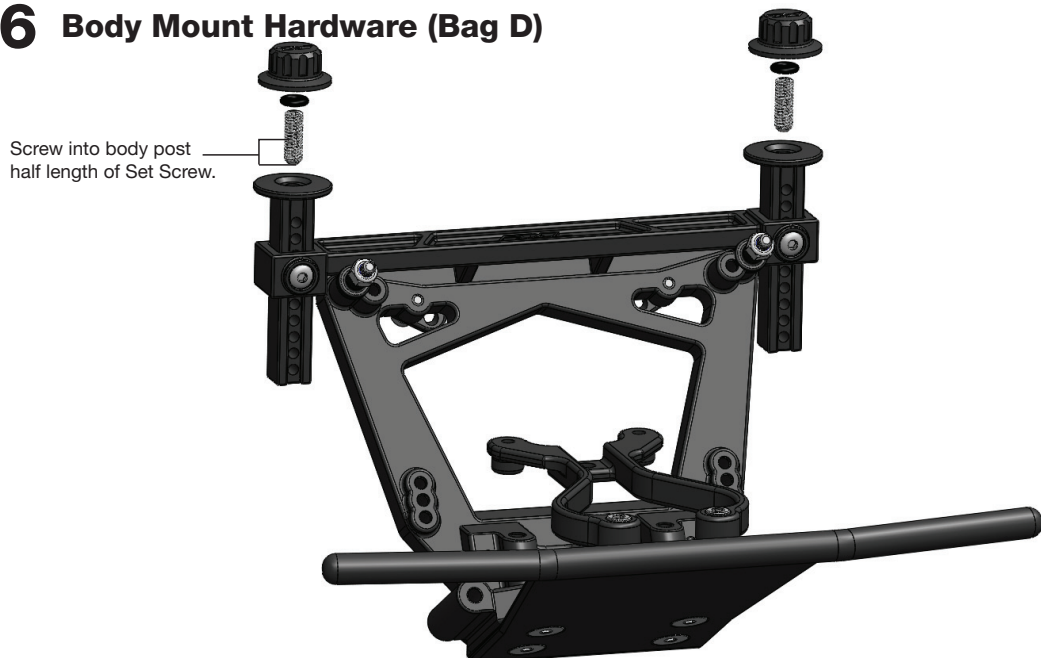

HARDWARE USED
(ACTUAL SIZE)

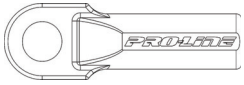

Long Rod Ends **x 4**

7 Front Camber Link Rod Ends (Bag E & ProTrac Bag)

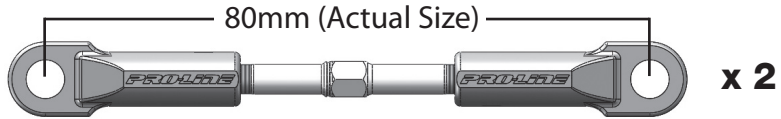

Use included turnbuckle wrench.

HARDWARE USED
(ACTUAL SIZE)



x 2

Small Inner Pivot Balls



x 2

Large Outer Pivot Balls

8 Front Camber Link Pivot Balls (Bag E)

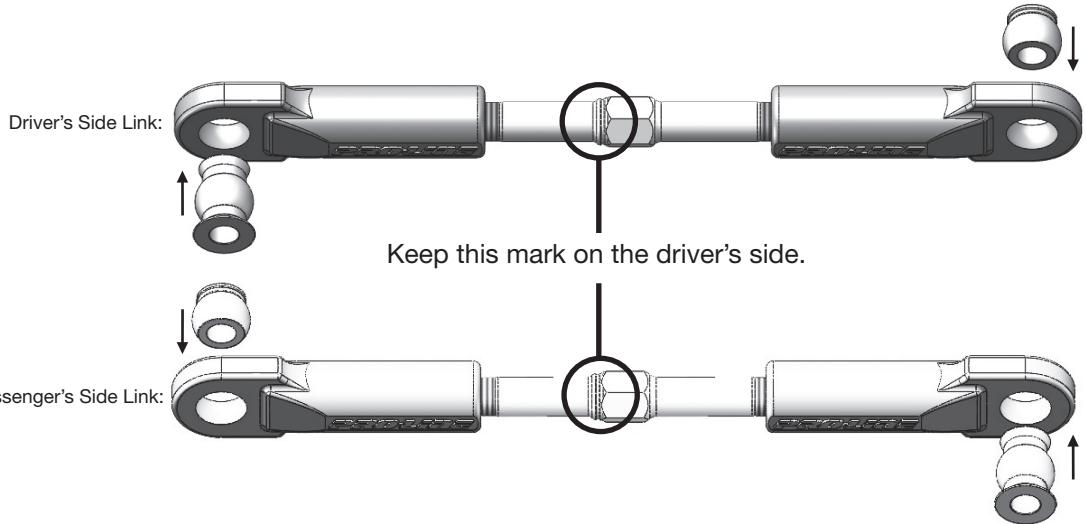

"Driver's Side" and "Passenger's Side" refers to U.S. standards.

HARDWARE USED
(ACTUAL SIZE)



x 2

M3 x 12 Low Profile

9 Front Camber Links to Shock Tower (Bag E)

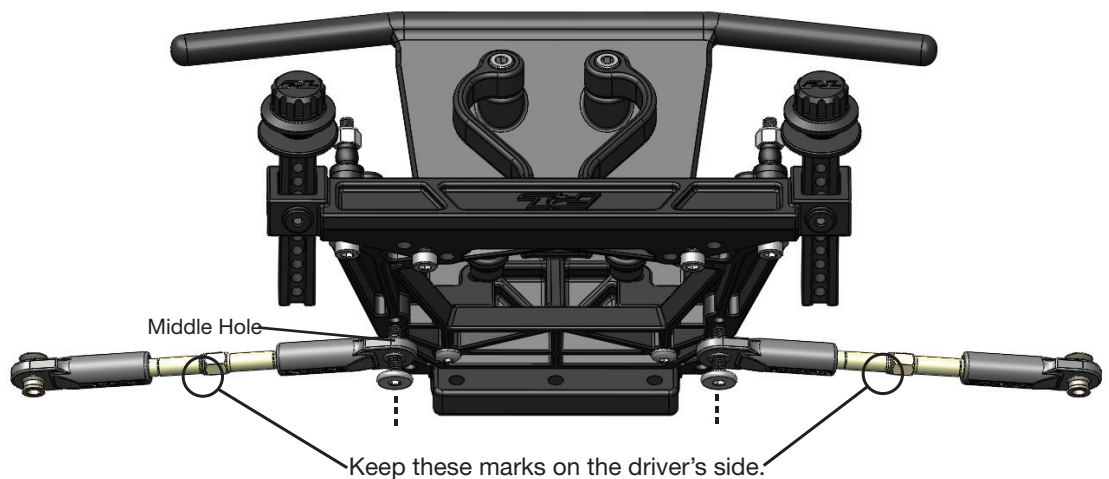

HARDWARE USED
(ACTUAL SIZE)

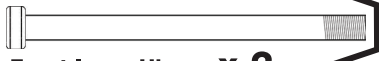

Front Inner Hinge X 2
(Bag F)



M3 Locknut
(Bag F)

Hinge Pin Brace X 2
(Bag B)

10 Front Arms and Hinge Pin Brace to Bulkhead (Bag B, F, & ProTrac Bag)

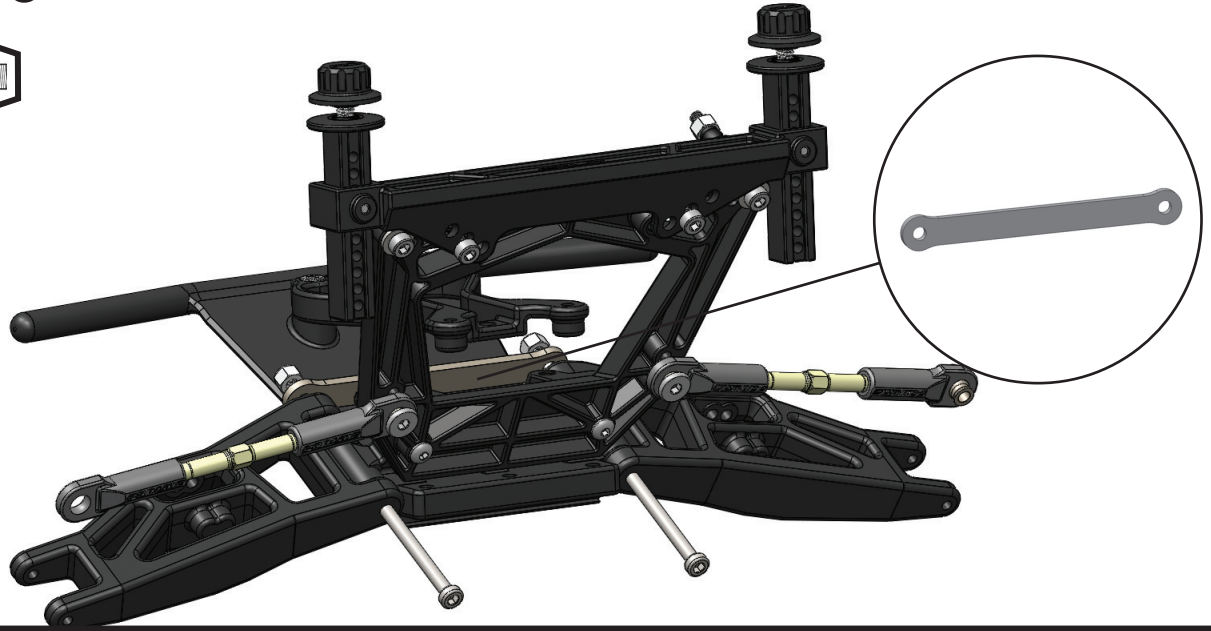

HARDWARE USED
(ACTUAL SIZE)



5 x 11 Bearing

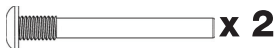

King Pins

Axle X 2

11 Front Hub Assembly (Bag G)

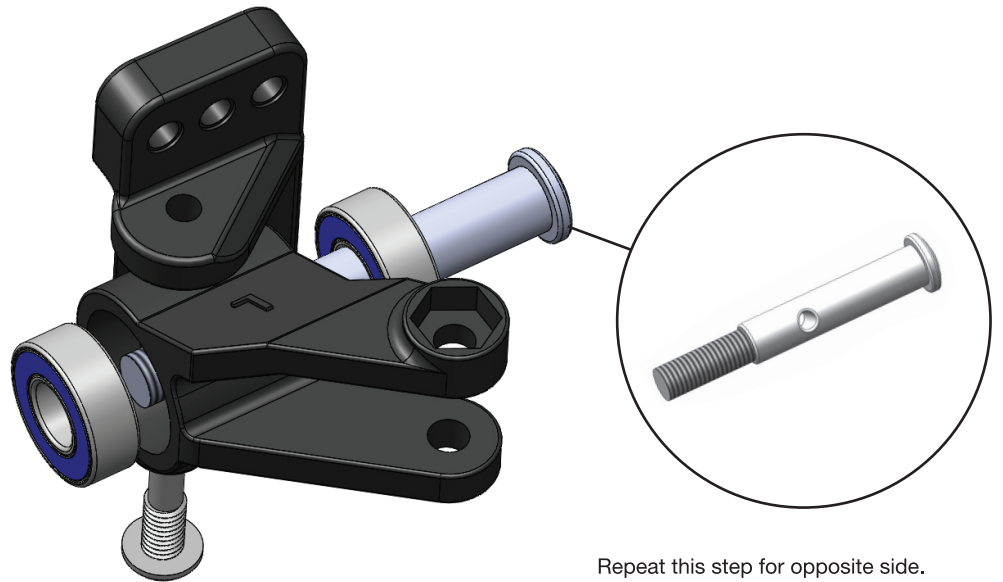

Repeat this step for opposite side.

HARDWARE USED
(ACTUAL SIZE)



Cross Pin
(Bag G)



5 x 8 x 0,25 Shims
(Bag G)



Serrated Locknut
(Bag G)



M 1.6 x 5 SHCS
(Bag H)

12 Front Wheel Hex Assembly (Bag G & Bag H)

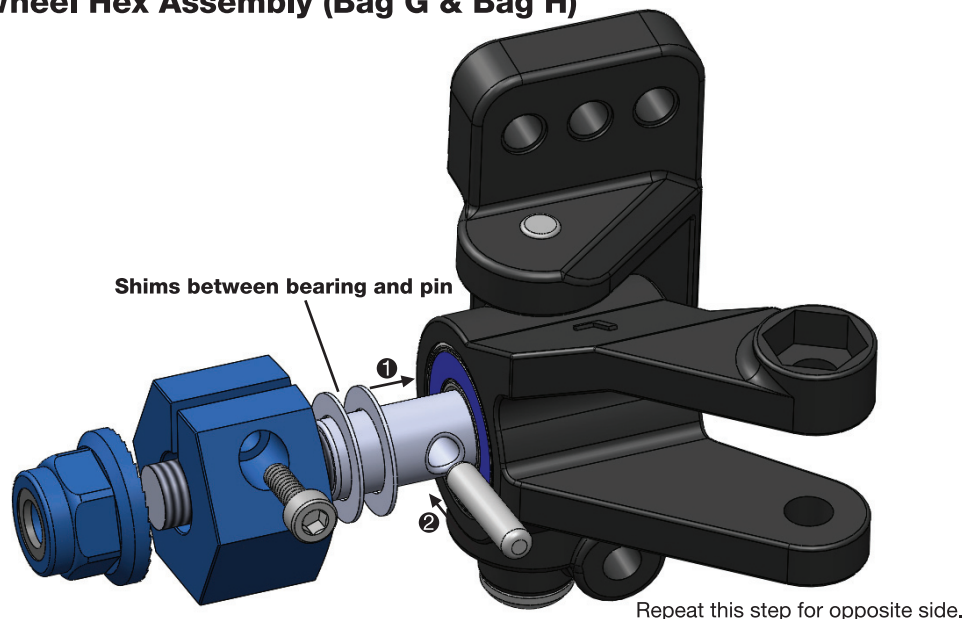

Repeat this step for opposite side.

HARDWARE USED
(ACTUAL SIZE)



Front Outer Hinge
(Bag F)



M2.5 Locknut
(Bag F)



M3 x 18 BHCS
(Bag G)



M3 Locknut
(Bag G)

13 Front Hub Assembly to Camber Link and Arm (Bag F & Bag G)

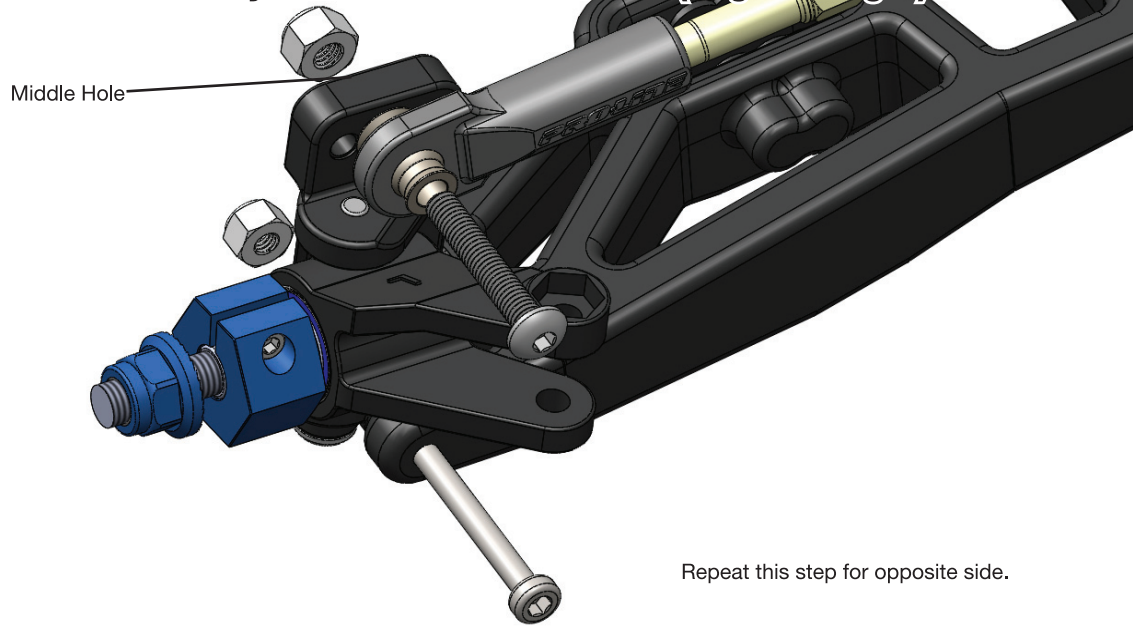

HARDWARE USED
(ACTUAL SIZE)



Short Rod Ends



Large Pivot Balls

14 Steering Links to Rod Ends and Pivot Balls (Bag E & ProTrac Bag)

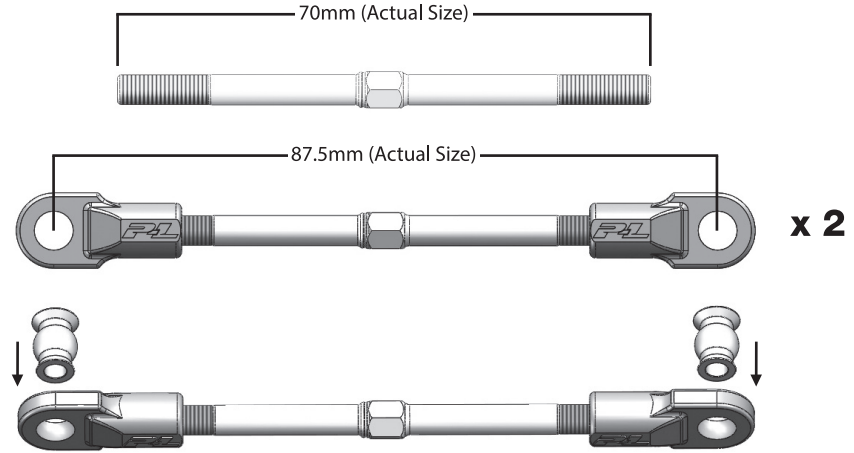

HARDWARE USED
(ACTUAL SIZE)



M3 x 18 BHCS



M3 Locknut

15 Steering Link to Steering Knuckle (Bag G)

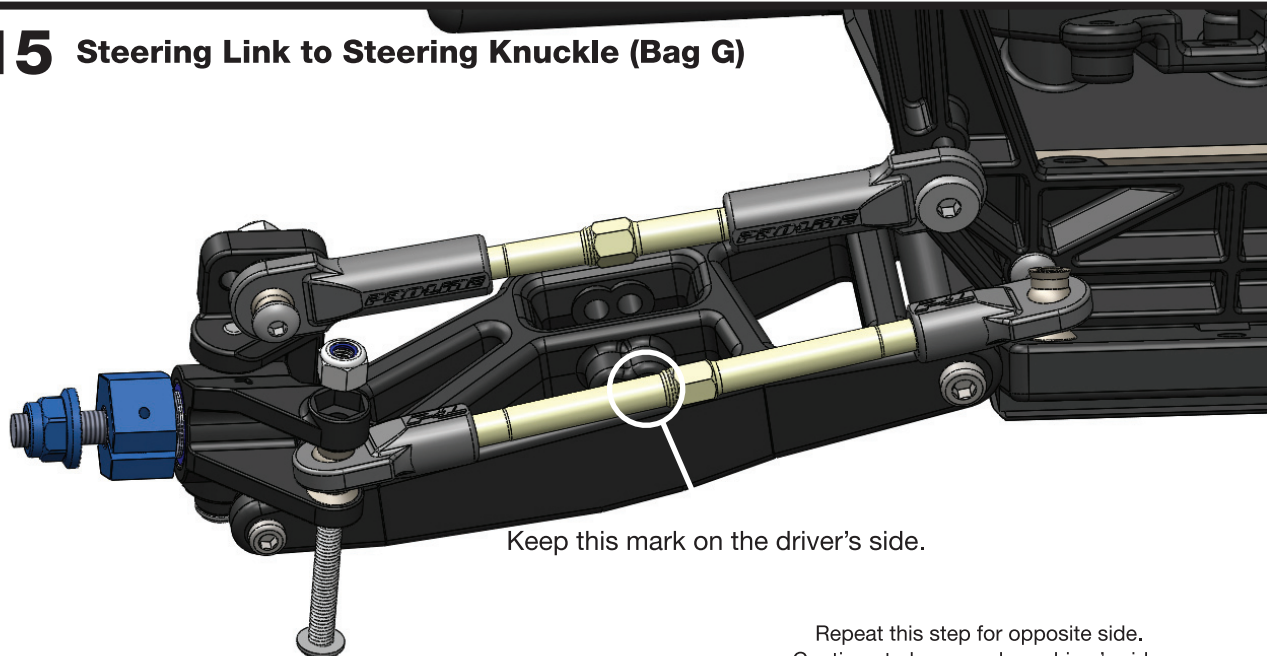

HARDWARE USED
(ACTUAL SIZE)

 **x 2**
M3 Locknut

16 Steerings Links to Steering Kit (Bag B)

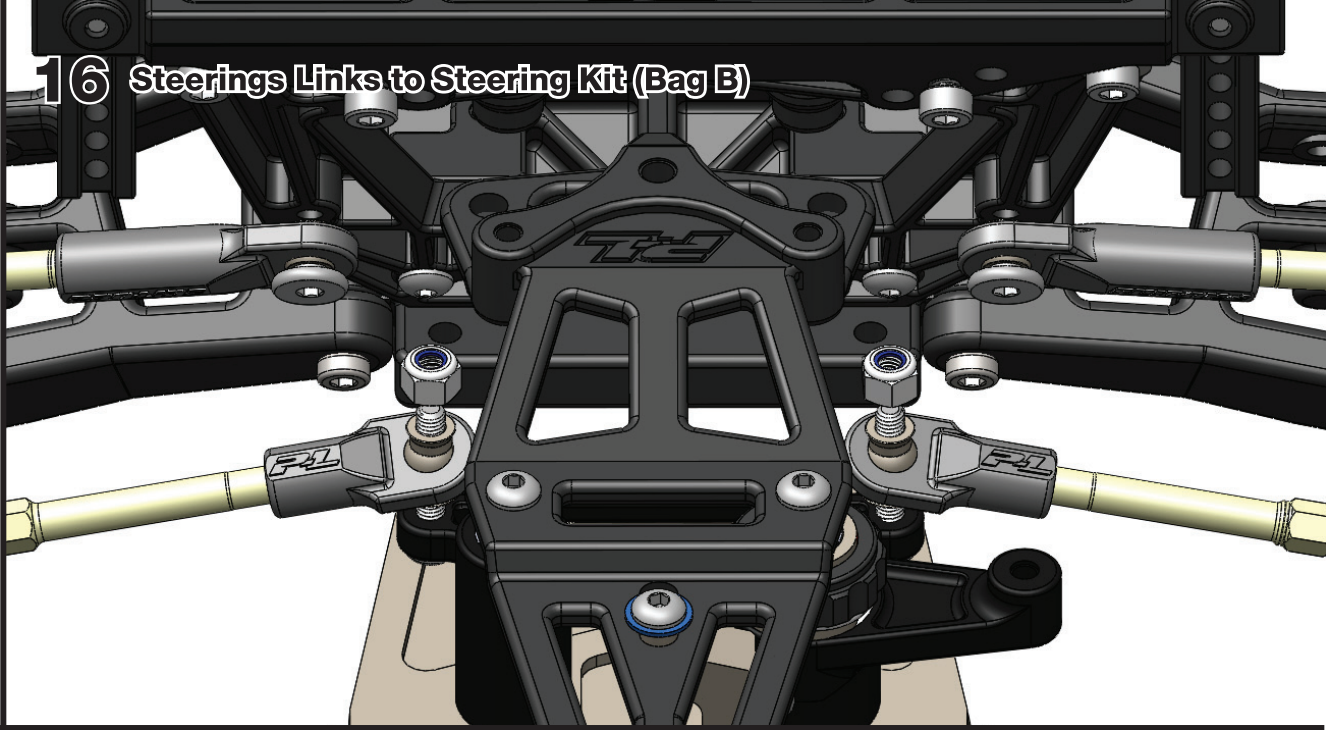

HARDWARE USED
(ACTUAL SIZE)

 **x 3**
M4 x 10 FHCS

17 Assemble Front End to Chassis (Bag B)

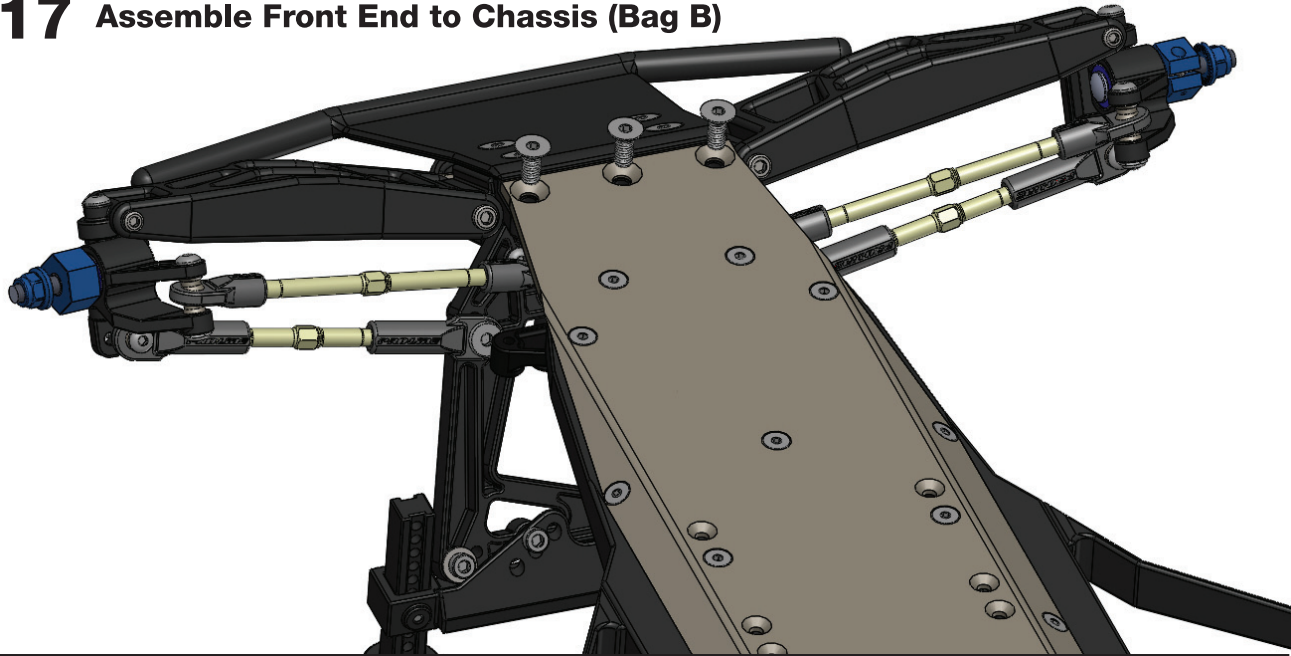

HARDWARE USED
(ACTUAL SIZE)

 **x 3**
M4 x 8 BHCS

 **x 2**
M3 x 16 BHCS

18 Front Bumper Brace to Front Bulkhead (Bag B)

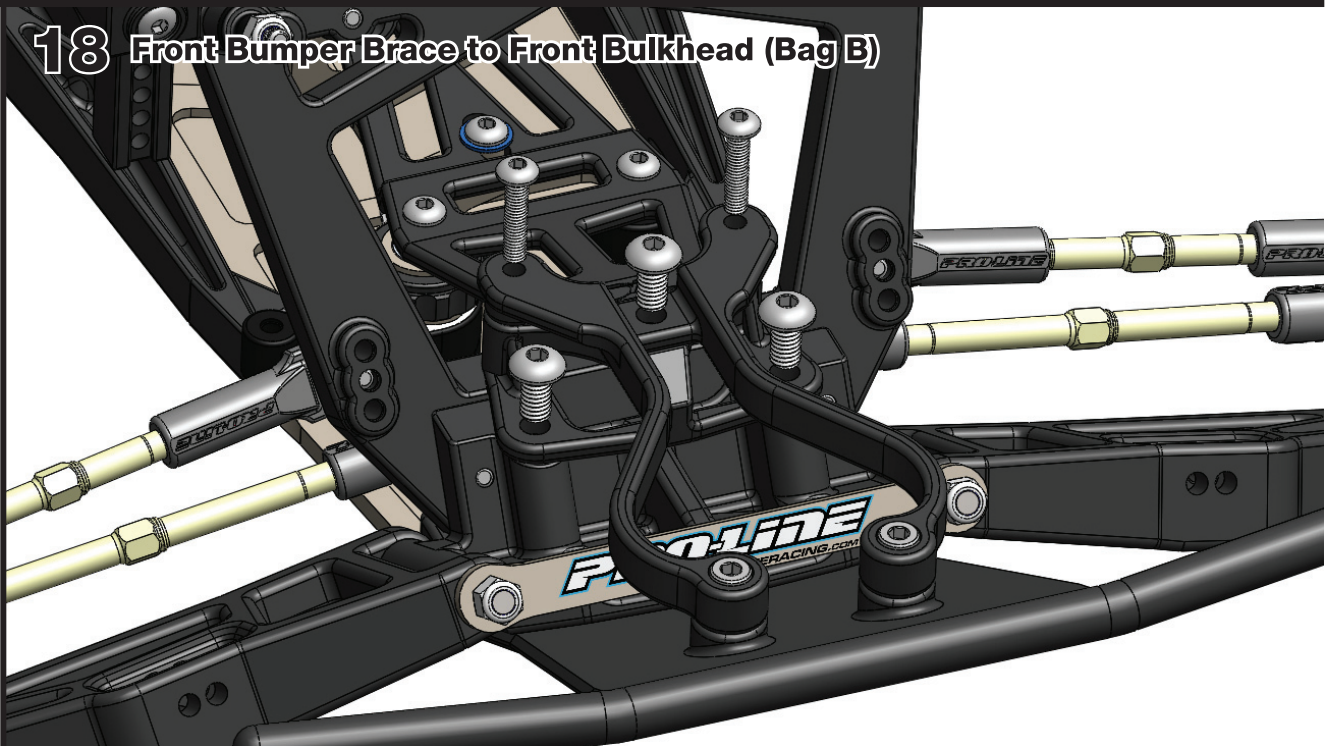

HARDWARE USED
(ACTUAL SIZE)



M3 x 25 SHCS



M3 Washers



Ball Ends



M3 Locknuts

19 Shock Mounting Hardware (Bag C & ProTrac Bag)

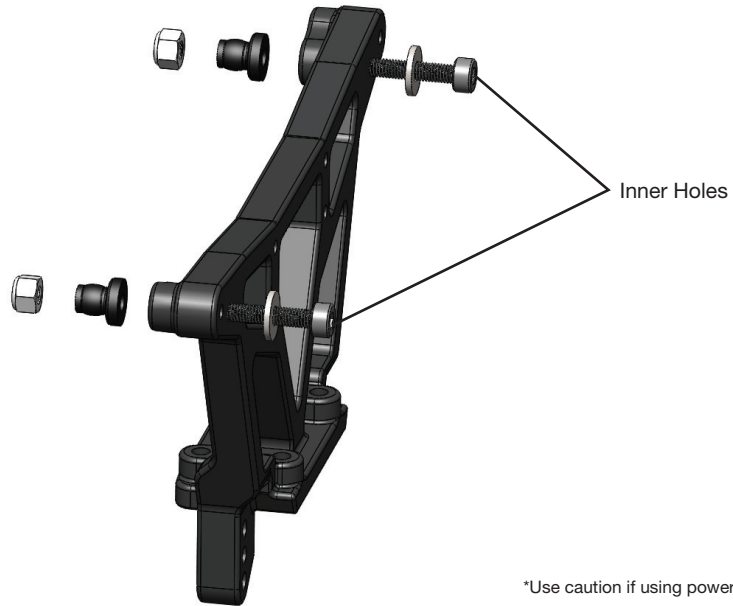

*Use caution if using power tools. Heat may melt plastic.

HARDWARE USED
(ACTUAL SIZE)

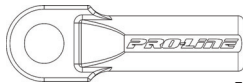

Long Rod Ends X 4

(50mm x 4mm) X 2
Camber Links



Large Pivot Balls



Small Inner Pivot Balls

20 Rear Camber Links to Rod Ends and Pivot Balls (Bag E & ProTrac Bag)

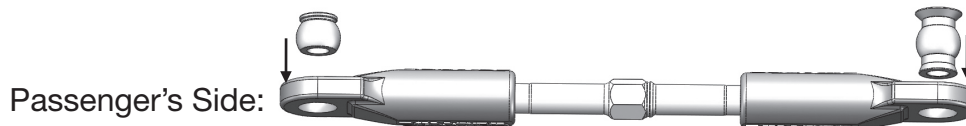
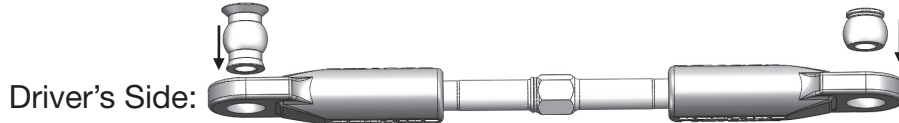
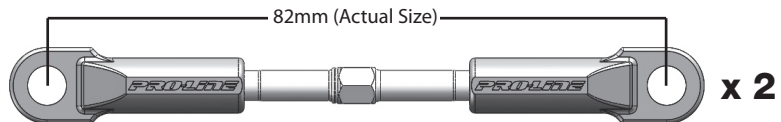
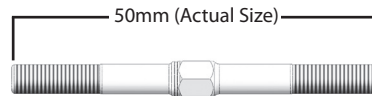

HARDWARE USED
(ACTUAL SIZE)



M3 x 12 Low Profile

21 Rear Camber Links to Shock Tower (Bag E)

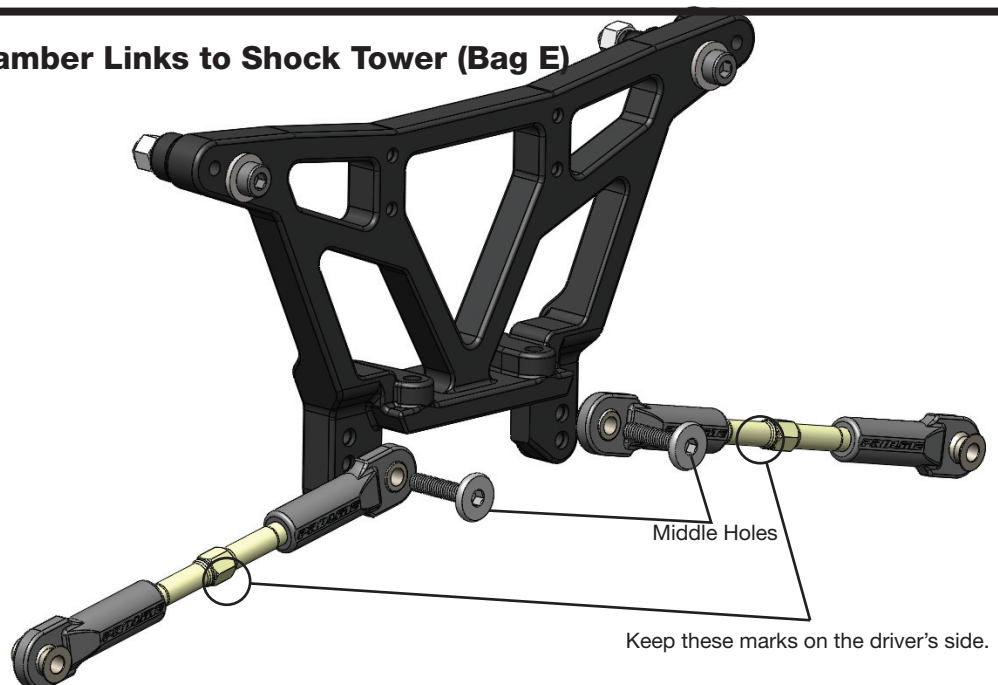

HARDWARE USED
(ACTUAL SIZE)

 **x 4**
M3 x 16 BHCS

22 Rear Shock Tower to Chassis (ProTrac Bag)

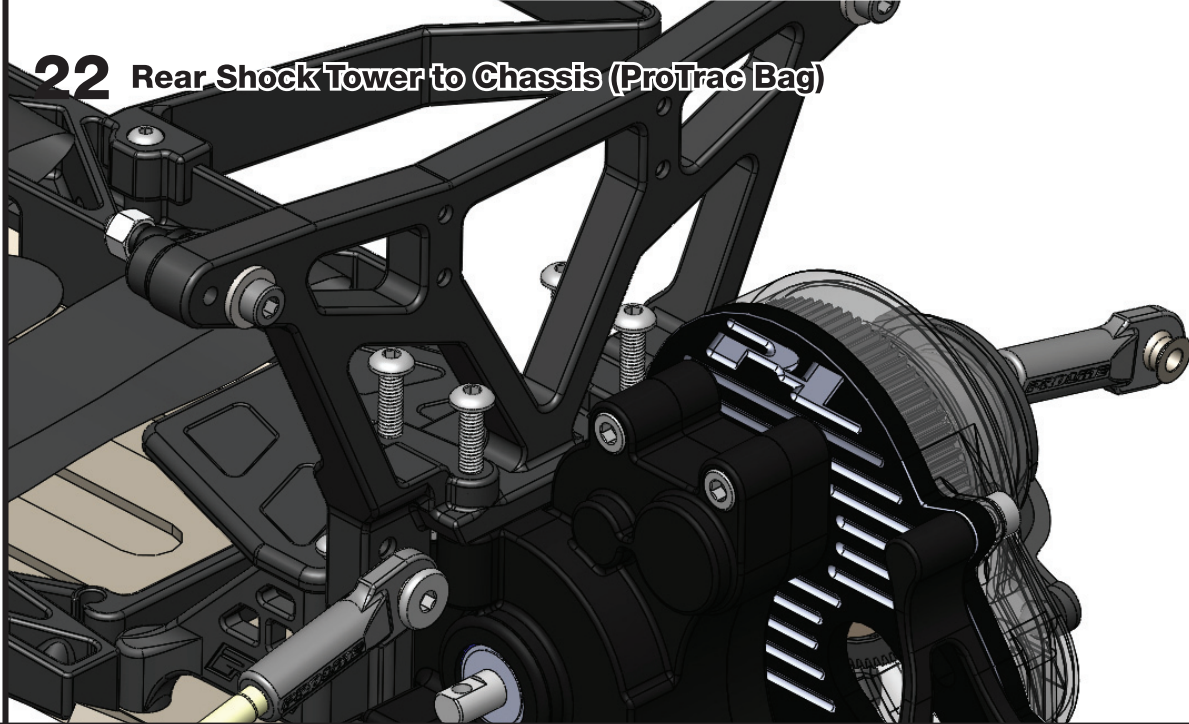

HARDWARE USED
(ACTUAL SIZE)

 **x 4**
M2.5 x 12 SHCS
(Bag B)

 **x 2**
M3 x 14 BHCS
(Bag D)

23 Rear Body Mount to Shock Tower (Bag B & Bag D)

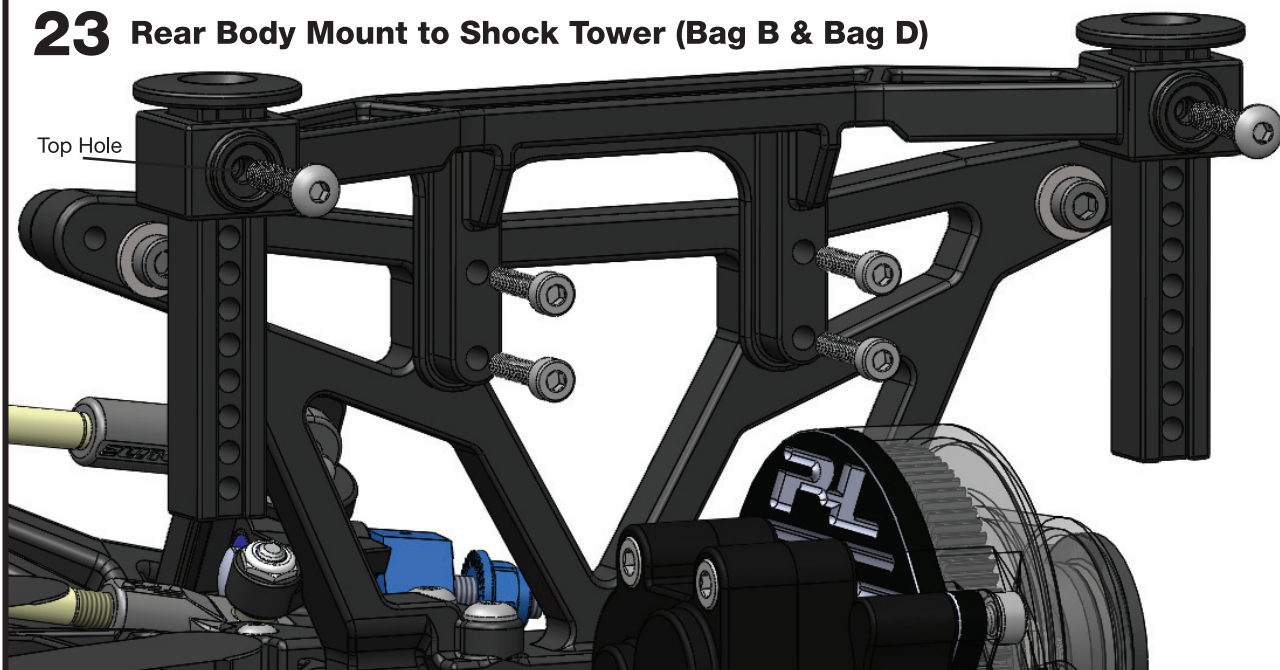

HARDWARE USED
(ACTUAL SIZE)

 **x 2**
Black O-Ring

 **x 2**
M4 x 12 Set Screw

 **x 2**
Secure-Loc Cap

24 Body Mount Hardware (Bag D)

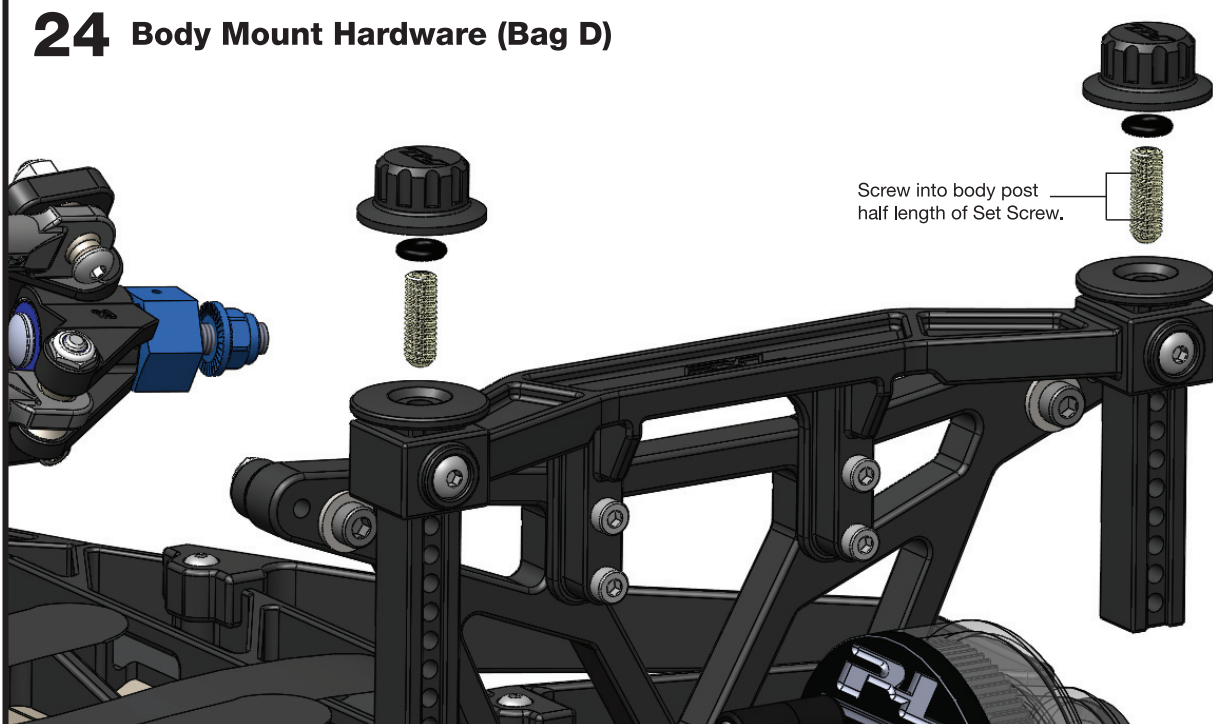



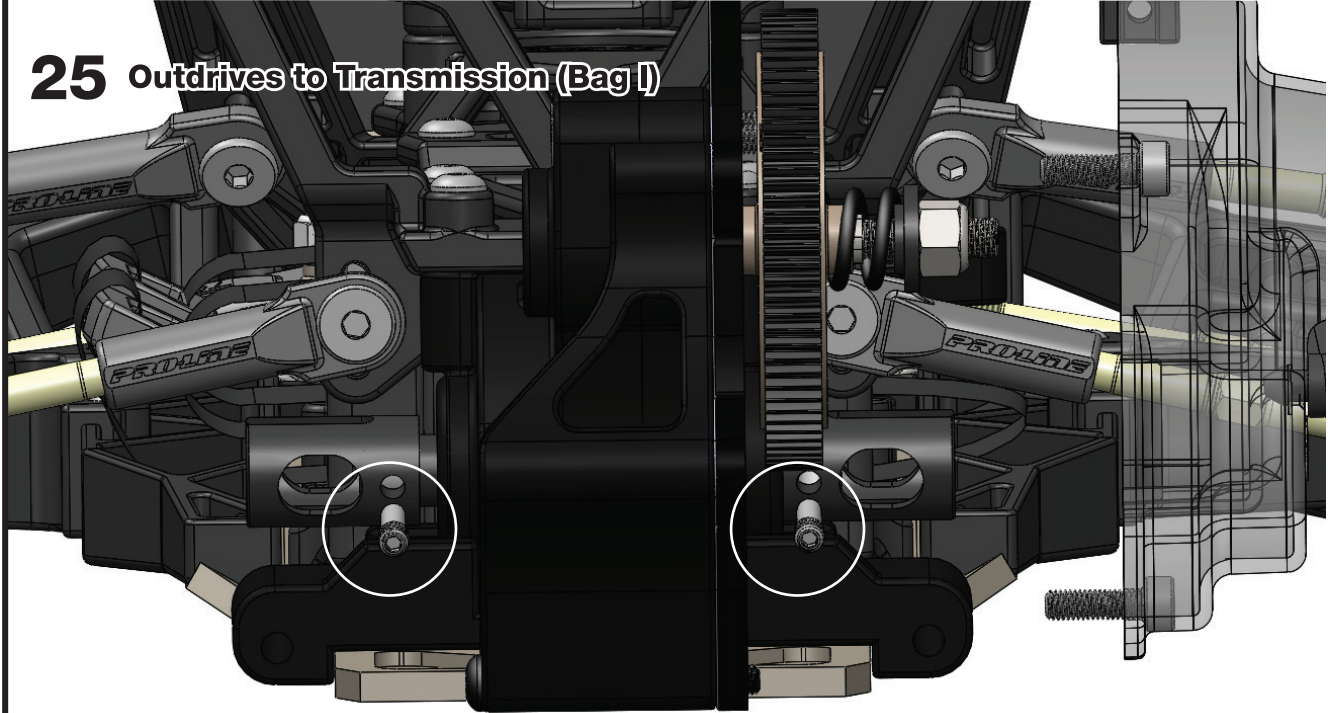

HARDWARE USED
(ACTUAL SIZE)

-  **X 2**
M3 x 10 Set Screw

25 Outdrives to Transmission (Bag I)



HARDWARE USED
(ACTUAL SIZE)



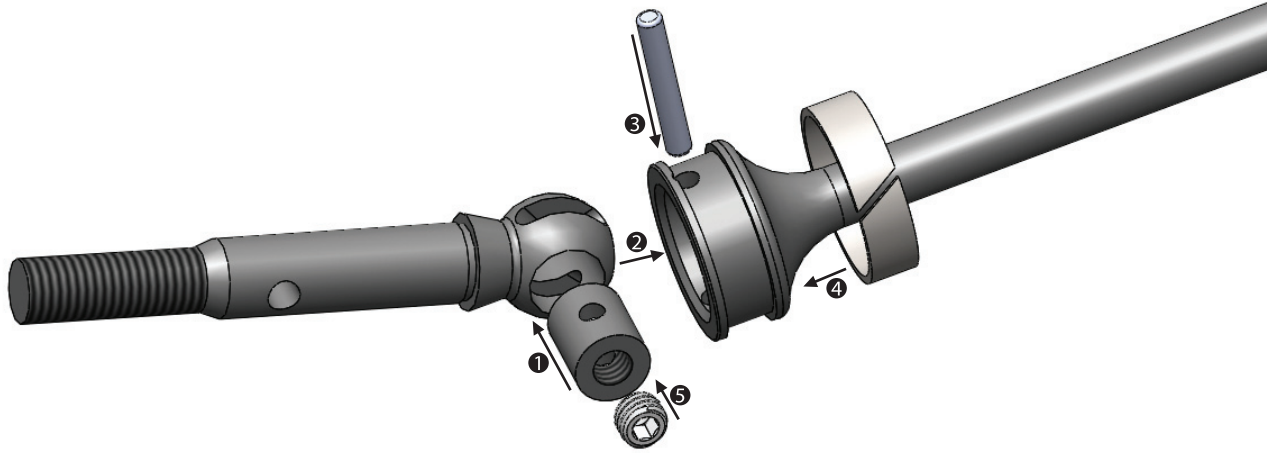

-  **X 2**
Drive Pin
-  **X 2**
Drive Pin Cup
- Axle X 2**
- Shaft X 2**
-  **X 2**
M3 Set Screw
-  **X 2**
Retainer Clip

26 Driveshaft Assembly (Bag I)



Repeat this step for opposite side.

HARDWARE USED
(ACTUAL SIZE)

-  **X 2**
Rear Outer Hinge Pin **X 2**
(Bag F)
-  **X 2**
Rear Inner Hinge Pin **X 2**
(Bag F)
-  **X 4**
M3 Locknut
(Bag F)
-  **X 4**
5 x 11 Bearings
(Bag I)

27 Rear Arms and Hub Carriers Assembly (Bag F, I, & ProTrac Bag)

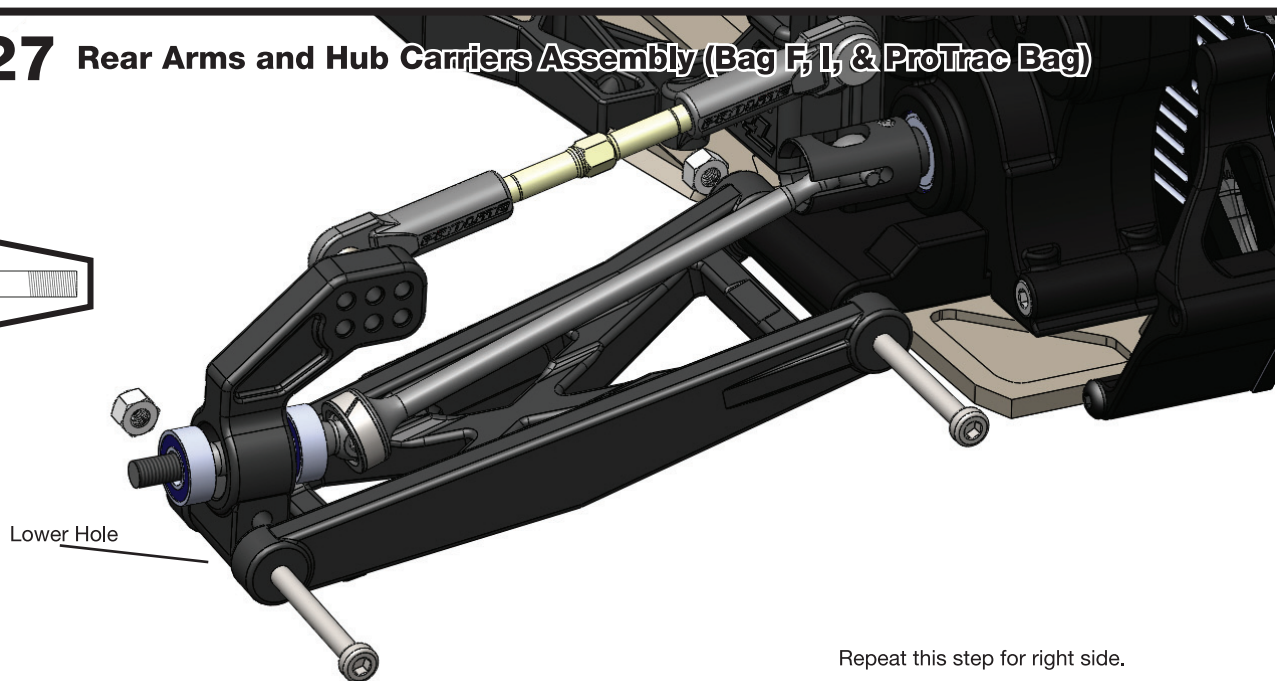

Repeat this step for right side.

HARDWARE USED

(ACTUAL SIZE)

 **x 4**

Cross Pin
(Bag I)

 **x 4**

5 x 8 x 0.25 Shims
(Bag I)

 **x 2**

M1.6 x 5 SHCS
(Bag J)

 **x 2**

Serated Locknut
(Bag I)

 **x 2**

M3 x 16 BHCS
(Bag I)

28 Rear Wheels Hex and Camber Link Assembly (Bag I & Bag J)

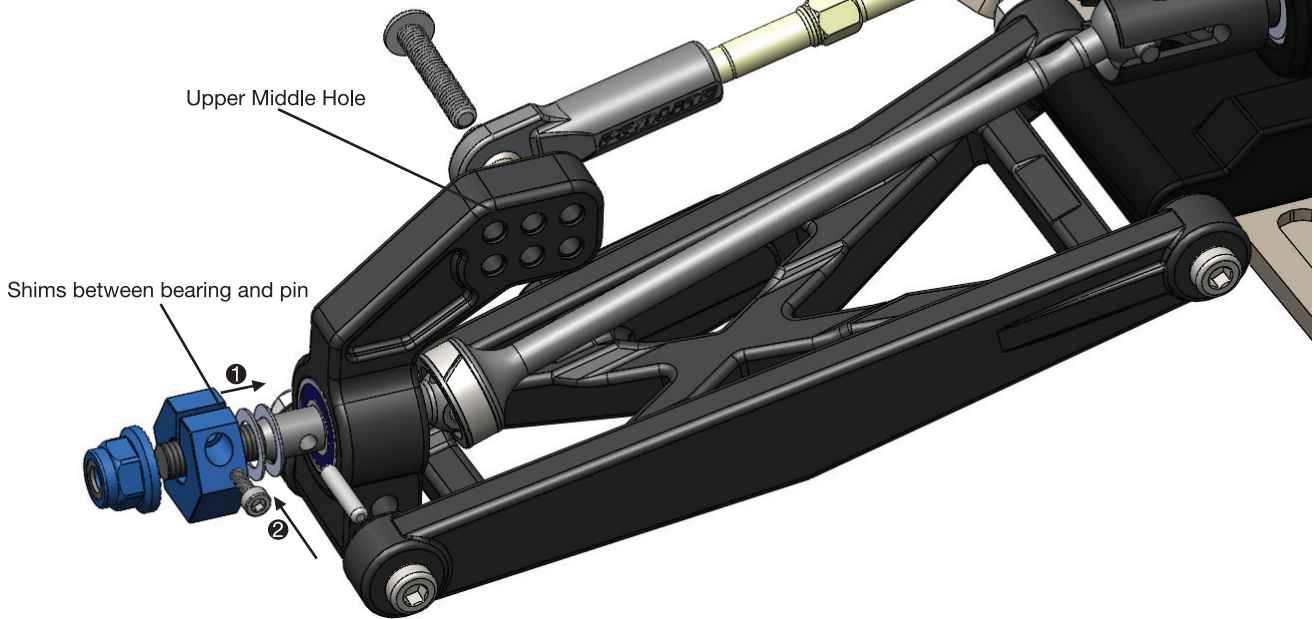

29 Remove Rear Motor Guard

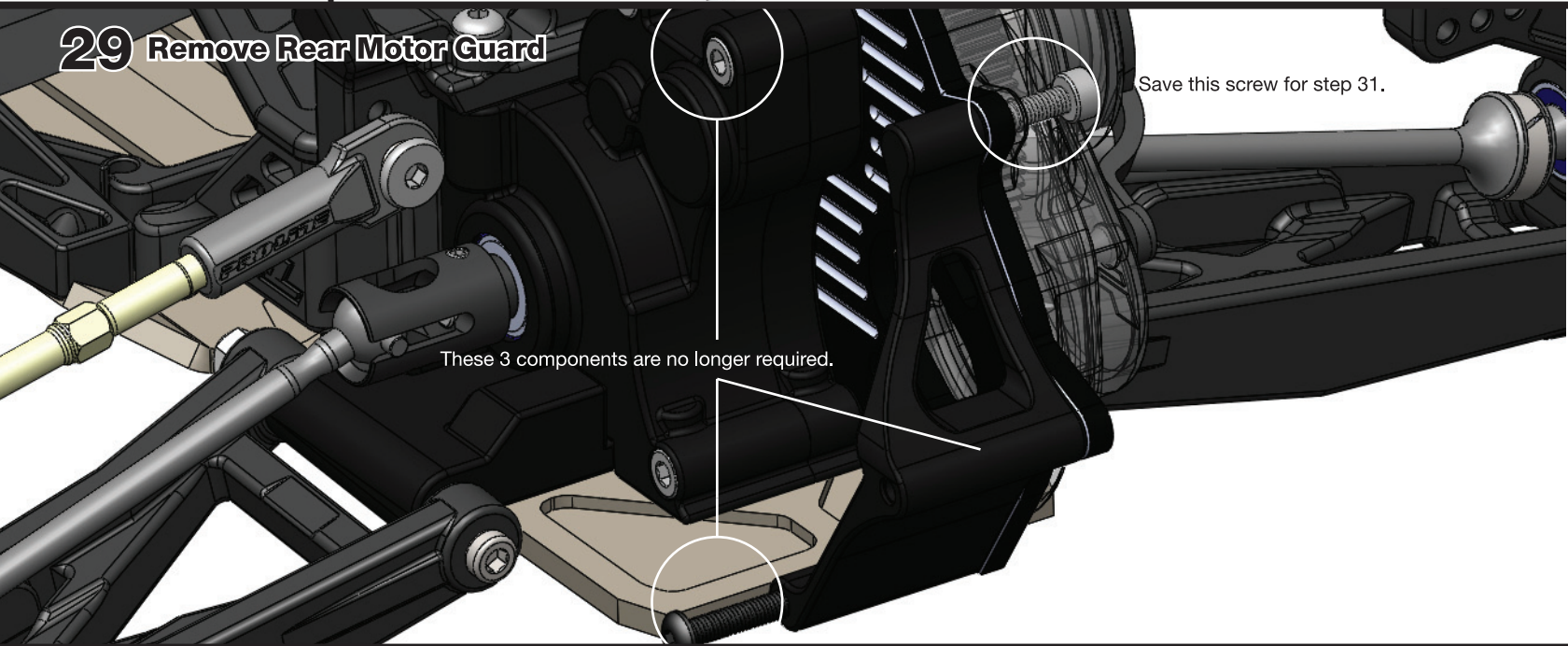

HARDWARE USED

(ACTUAL SIZE)

 **x 2**

M3 x 8 SHCS

30 Rear Bumper to Brace (Bag K)



HARDWARE USED
(ACTUAL SIZE)

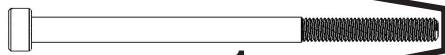

M3 x 54 SHCS X 1



x 1
M3 Locknut



x 2
M3 x 10 SHCS

Reinstall
Gear Cover Screws
from Step 25

31 Rear Bumper to Transmission (Bag K)

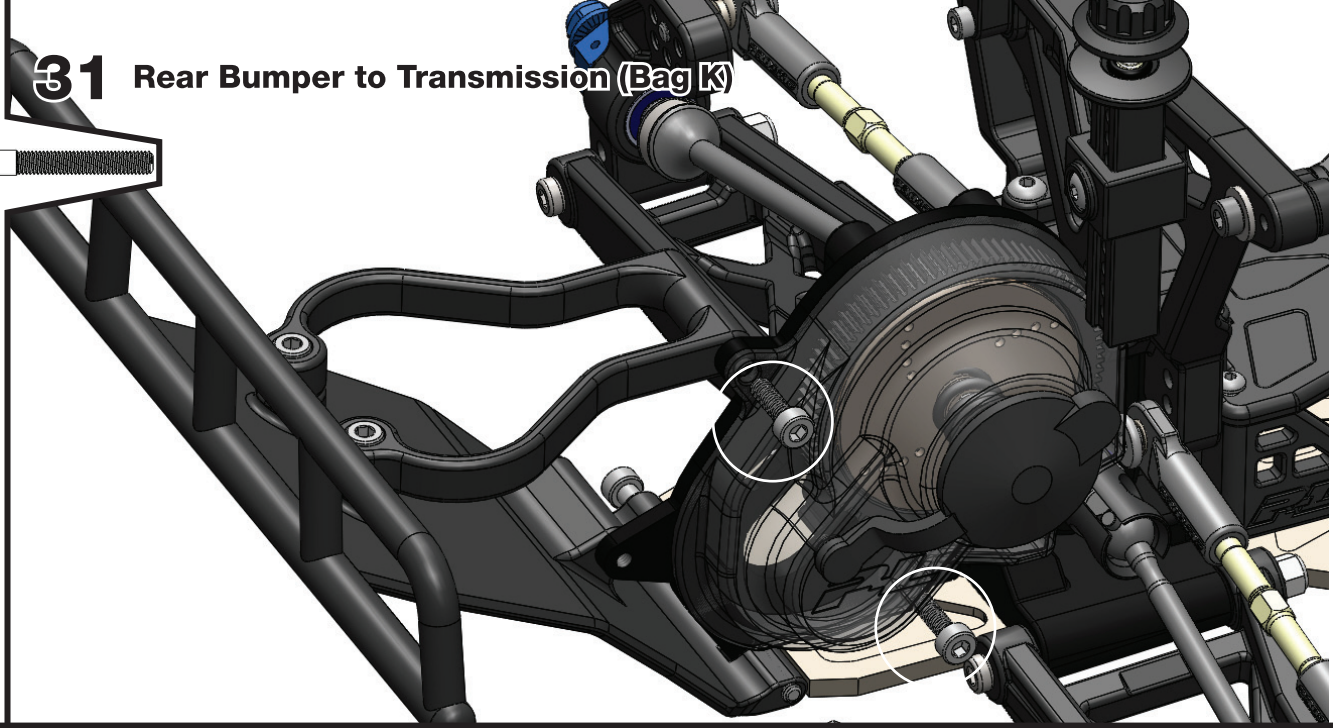

HARDWARE USED
(ACTUAL SIZE)



x 1
M3 x 20 SHCS



x 1
M3 x 16 SHCS



x 1
M3 x 30 SHCS



x 1
M3 Locknut

32 Bumper Brace Assembly (Bag K)

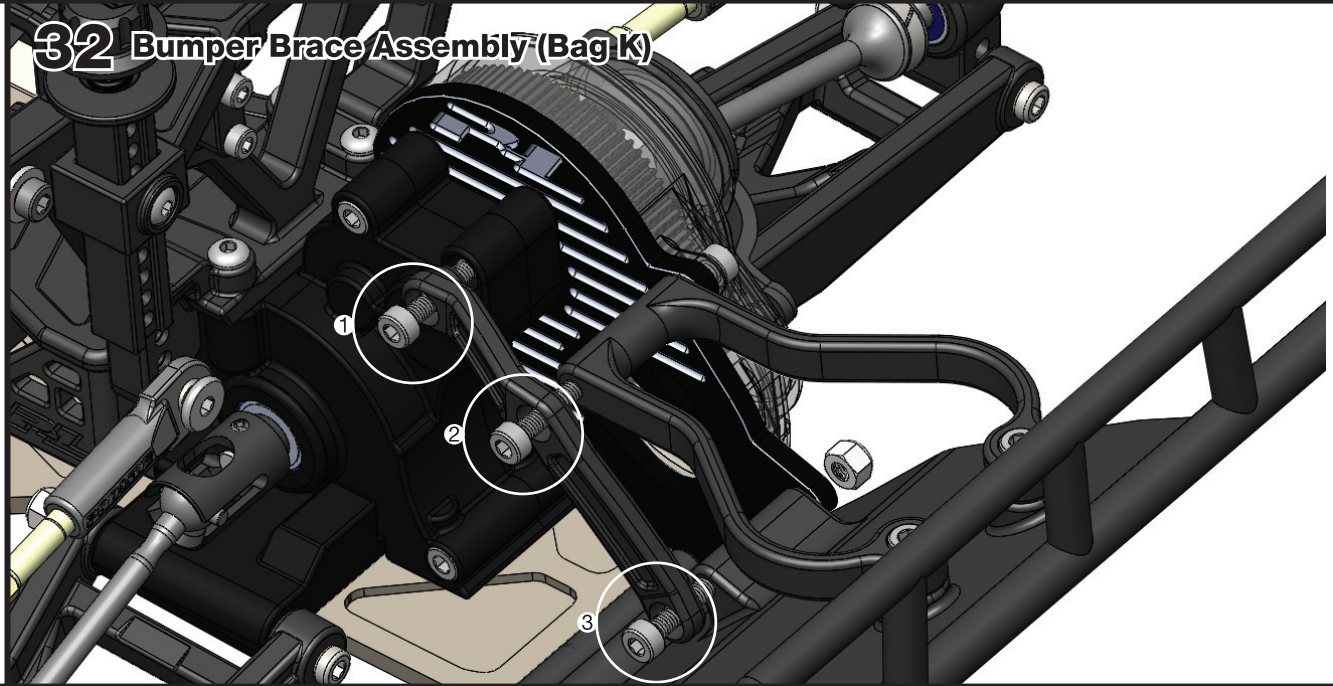

33 Shock Setup (Fluids Bag)

1. Remove Springs
2. Fill with oil
3. Bleed
4. Tighten
5. Replace Springs

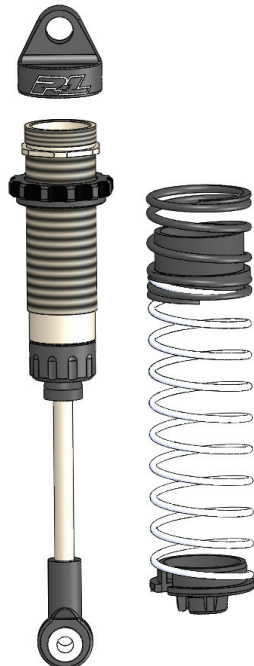

POWERSTROKE
PERFORMANCE SHOCKS



Visit p-l.com/pro-2/build
for shock assembly videos
and spring rate charts.

HARDWARE USED
(ACTUAL SIZE)

 x 2
M3 x 16 BHCS

34 Install Rear Shocks (Bag C)

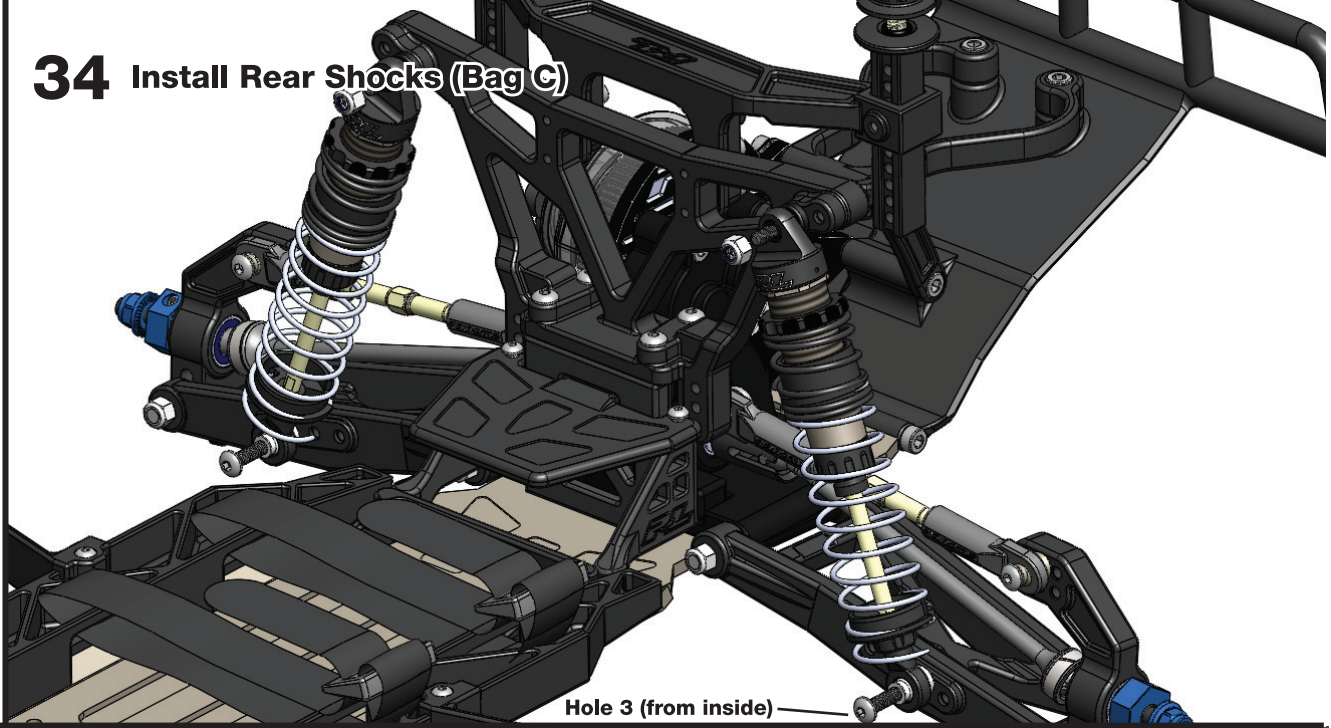

HARDWARE USED
(ACTUAL SIZE)

 x 2
M3 x 16 BHCS

35 Install Front Shocks (Bag C)

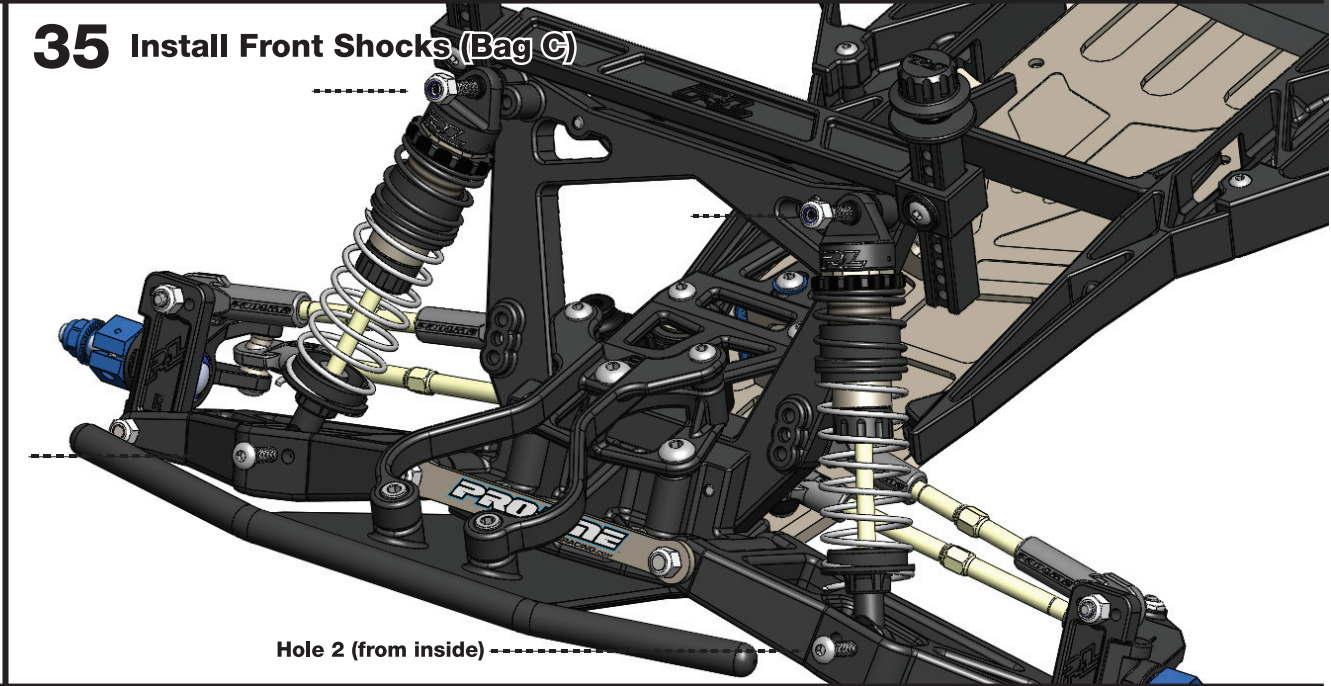

36 Electronics Placement (Foam Bag)

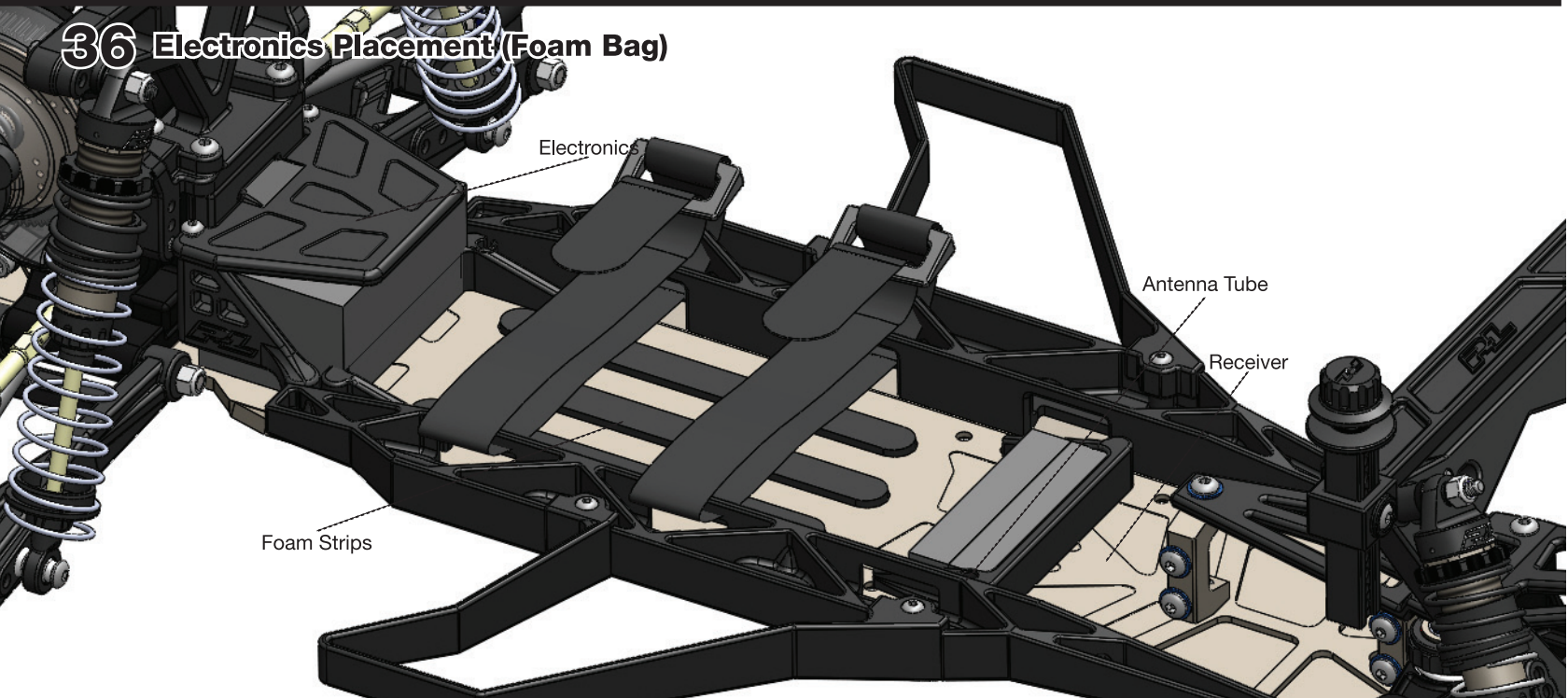

HARDWARE USED
(ACTUAL SIZE)

Steering Rod



Small Rod Ends



x 1

Large Pivot Balls

37 Servo Link (Bag L & Bag E)



2.0" (Actual Size)

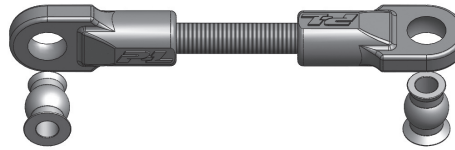

HARDWARE USED
(ACTUAL SIZE)



M3 x 16 BHCS



x 2

3 x 7 x 2.5 Washer

38 Servo Installation (Bag L)

1. Install Servo
2. Tighten Screws
3. Zero out at vertical
4. Align link straight with spacers

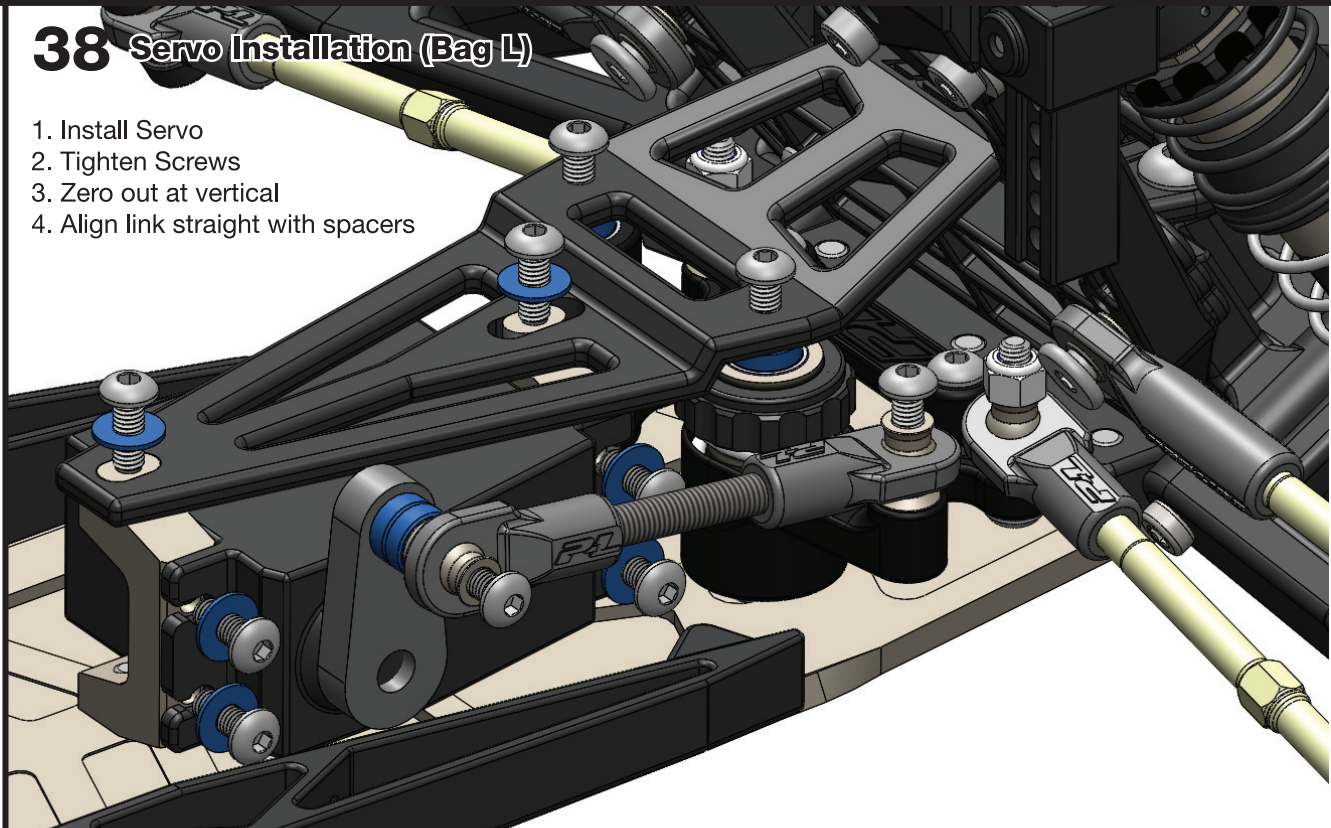

HARDWARE USED
(ACTUAL SIZE)



M3 x 8 SHCS



x 2

HD Motor Washers

39 Gear Cover Installation (Bag L)

1. Install motor
2. Set gear mesh
3. Reinstall gear cover

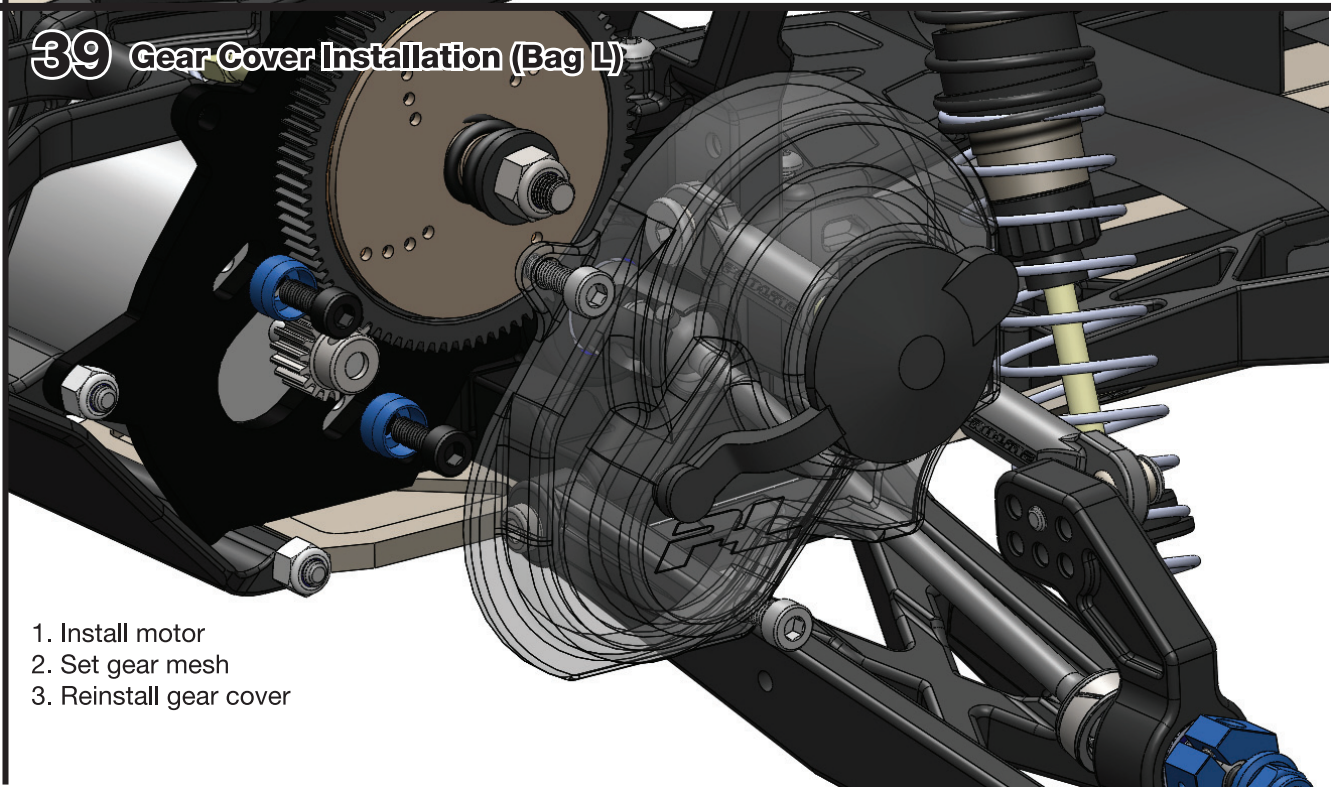

40 Install Pre-Mounted Tires (Tire Bag)

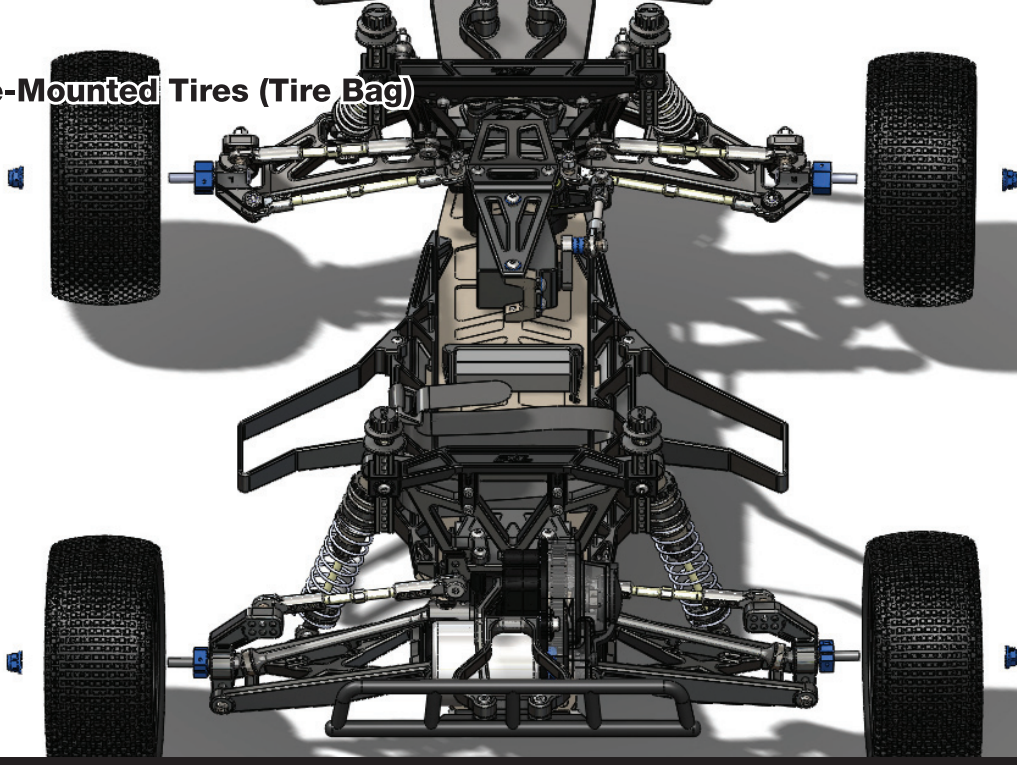

41 Paint Body

1. Wash body with soap.
2. Rinse and dry thoroughly.
3. Install window masks.
4. Paint body with Lexan/polycarbonate safe paint.
5. Allow paint to dry completely.
6. Remove window masks and outer film.
7. Cut body along guidelines.
8. Ream body holes marked for PRO-2.
9. Apply decals.



Visit p-l.com/pro-2/build for paint instruction videos.

PRO-2



PRO-2

PRO-LINE
FLO-TEK

Congratulations! Enjoy your Pro-Line Pro-2 Short Course Truck!



Pro-2 Kit Replacement Parts

6092-00 Performance Transmission 6092-01 Transmission Plastics 6092-02 Gear Cover & Plug 6092-03 Motor Plate 6092-04 Transmission Hardware 6092-05 Diff Housing & Idler Gear 6092-06 Diff Internal Gears 6092-07 86T Spur Gear (Stock) 6092-08 Diff Seal Kit 6092-09 Top Shaft & Slipper Plates 6092-10 Slipper Pads 6092-11 Ball Bearings	6093-00 PRO-2 LCG Chassis 6093-01 Chassis Replacement 6093-02 Side Pod Plastics 6093-03 Internal Plastics 6093-04 Servo Mounts & Hardware 6093-05 Steering Posts & Hardware	6092-16 HD Motor Washers 6092-16 HD Motor Washers
6063-00 Power Stroke Shocks (Front) 6063-02 Shock Rebuild Kit 6063-03 Front Spring Assortment Kit 6063-05 Mounting Hardware 6063-06 Front Shaft Replacment (2)	6062-00 ProTrac Suspension Kit 6062-01 Front Arms 6062-02 Rear Arms 6062-03 Front Shock Tower 6062-04 Rear Shock Tower 6062-05 Rear Hub Carriers 6062-06 Camber Links (2) 6062-07 Steering Links (2)	6100-00 4mm Serrated Wheel Nuts 6100-00 4mm Serrated Wheel Nuts
6063-01 Power Stroke Shocks (Rear) 6063-02 Shock Rebuild Kit 6063-04 Rear Spring Assortment Kit 6063-05 Mounting Hardware 6063-07 Rear Shaft Replacment (2)	6067-00 Performance Steering Kit 6067-00 Performance Steering Kit	1183-25 Blockade M3 on F-11 Wheels 1183-25 Blockade M3 on F-11 Wheels
6101-00 PRO-2 Front Hub Kit 6101-01 Front Hub Plastics 6101-02 Steel King Pins (4)	6070-00 Extended Body Mount Kit 6070-01 Body Mount Plastics 6070-02 Thumbwashers & Hardware	6096-00 PRO-2 Hinge Pin Set 6096-00 PRO-2 Hinge Pin Set
	6102-00 Pivot Ball & Rod End Set 6102-00 Pivot Ball & Rod End Set	6099-00 PRO-2 ProTrac Axle Kit 6099-00 PRO-2 ProTrac Axle Kit
	6104-00 Front Hinge Pin Brace 6104-00 Front Hinge Pin Brace	3355-00 Flo-Tek Clear Body 3355-00 Flo-Tek Clear Body
		6095-00 PRO-2 Front Bumper & Bulkhead 6095-00 PRO-2 Front Bumper & Bulkhead
		6097-00 PRO-2 Front Clamping Hex 6097-00 PRO-2 Front Clamping Hex
		6092-14 PRO-2 Rear Bumper 6092-14 PRO-2 Rear Bumper
		6098-00 PRO-2 Rear Clamping Hex 6098-00 PRO-2 Rear Clamping Hex

Optional Parts

6092-12 Optional Anti-Squat Blocks 6092-12 Optional Anit-Squat Blocks	6092-15 Optional 82T Spur Gear 6092-15 Optional 82T Spur Gear	6063-04 Rear Spring Assortment Kit 6063-04 Rear Spring Assortment Kit
6092-13 Optional 78T Spur Gear 6092-13 Optional 78T Spur Gear	6063-03 Front Spring Assortment Kit 6063-03 Front Spring Assortment Kit	<p>Go To ProlineRacing.com for the latest Tires, Wheels, Bodies & Accessories for your PRO-2!</p>

PRO-2 SETUP SHEET

TRACK: Stock Pro-2 Setup
 EVENT: _____
 DRIVER: _____ DATE: _____
 QUAL: _____ FINISH: _____

FRONT SUSPENSION

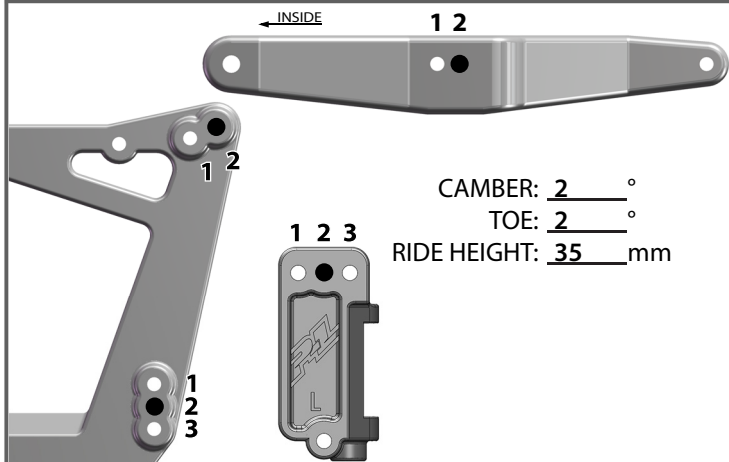

CAMBER: 2 °
 TOE: 2 °
 RIDE HEIGHT: 35 mm

POWERSTROKE FRONT SHOCKS

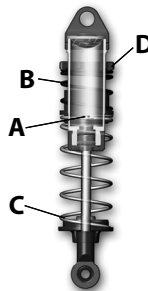

(A) PISTON: Stock
 OIL WEIGHT: 35 wt
 (B) PRIMARY SPRING: Yellow
 (C) SECONDARY SPRING: Green
 DROOP SPACER: _____ mm
 COMPRESSION SPACER: _____ mm
 (D) SPRING ADJUSTMENT: _____ mm

REAR SUSPENSION

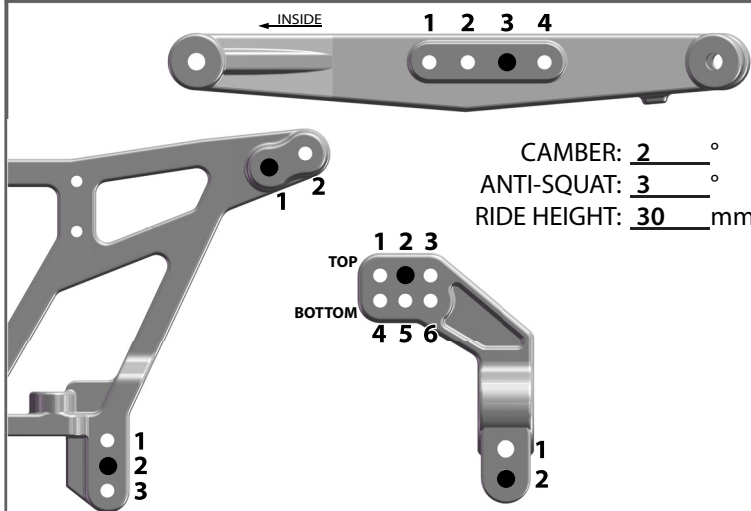

CAMBER: 2 °
 ANTI-SQUAT: 3 °
 RIDE HEIGHT: 30 mm

POWERSTROKE REAR SHOCKS

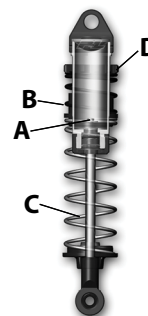

(A) PISTON: Stock
 OIL WEIGHT: 35 wt
 (B) PRIMARY SPRING: Yellow
 (C) SECONDARY SPRING: Green
 DROOP SPACER: _____ mm
 COMPRESSION SPACER: _____ mm
 (D) SPRING ADJUSTMENT: _____ mm

ELECTRONICS

MOTOR: _____
 ESC: _____
 RECEIVER: _____
 SERVO: _____
 RADIO: _____

TRACK INFORMATION

TRACTION: HIGH MED LOW
 SURFACE: SMOOTH BUMPY BLUE GROOVE
 CONDITIONS: SOFT DIRT CLAY WET DUSTY
 OTHER: _____

FRONT TIRES

TIRE: Blockade SC
 COMPOUND: M3
 INSERT: Closed Cell
 WHEEL: F-11 Pro-Trac

REAR TIRES

TIRE: Blockade SC
 COMPOUND: M3
 INSERT: Closed Cell
 WHEEL: F-11 Pro-Trac

BATTERY PLACEMENT

BATTERY: _____
 PLACEMENT: _____

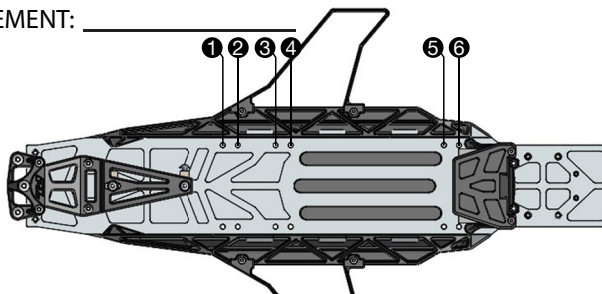

TRANSMISSION SETTINGS

PINION: _____
 SPUR GEAR: Stock 86 tooth
 DIFF. OIL: Stock 5,000 wt.

NOTES

For complete step-by-step instructions
 visit PROLINERACING.com



TRACK: _____
 EVENT: _____
 DRIVER: _____ DATE: _____
 QUAL: _____ FINISH: _____

PRO-LINE

SETUP SHEET

FRONT SUSPENSION

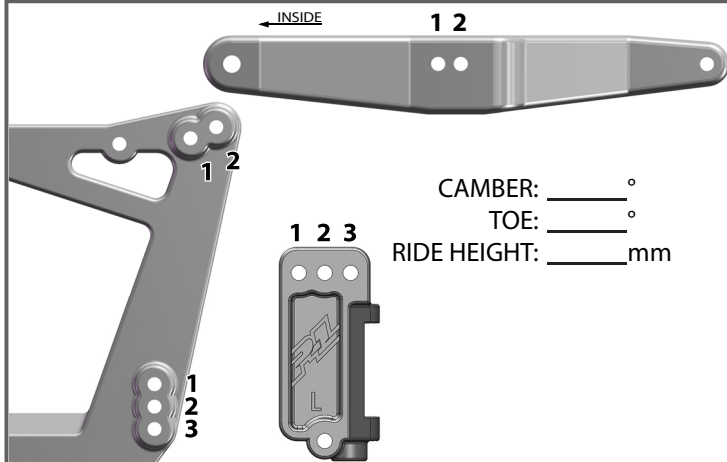

CAMBER: _____ °
 TOE: _____ °
 RIDE HEIGHT: _____ mm

POWERSTROKE FRONT SHOCKS

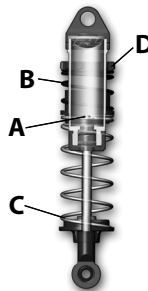

(A) PISTON: _____
 OIL WEIGHT: _____
 (B) PRIMARY SPRING: _____
 (C) SECONDARY SPRING: _____
 DROOP SPACER: _____ mm
 COMPRESSION SPACER: _____ mm
 (D) SPRING ADJUSTMENT: _____ mm

REAR SUSPENSION

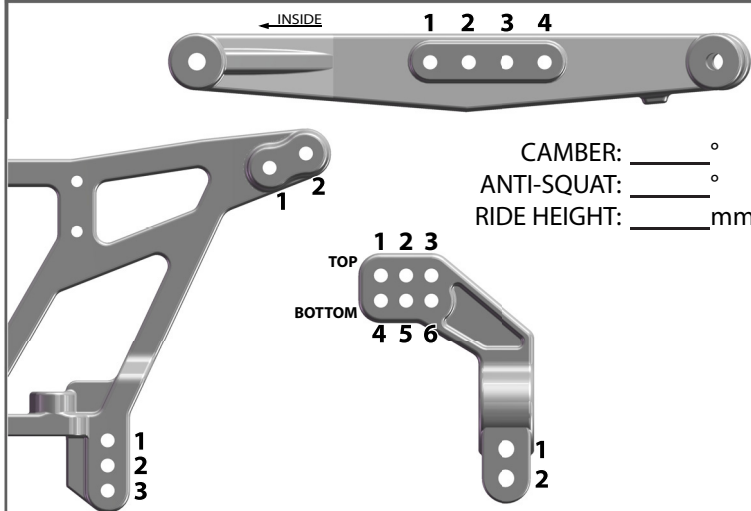

CAMBER: _____ °
 ANTI-SQUAT: _____ °
 RIDE HEIGHT: _____ mm

POWERSTROKE REAR SHOCKS

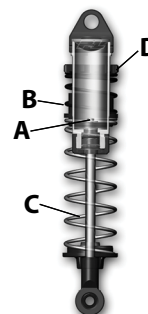

(A) PISTON: _____
 OIL WEIGHT: _____
 (B) PRIMARY SPRING: _____
 (C) SECONDARY SPRING: _____
 DROOP SPACER: _____ mm
 COMPRESSION SPACER: _____ mm
 (D) SPRING ADJUSTMENT: _____ mm

ELECTRONICS

MOTOR: _____
 ESC: _____
 RECEIVER: _____
 SERVO: _____
 RADIO: _____

TRACK INFORMATION

TRACTION: HIGH MED LOW
 SURFACE: SMOOTH BUMPY BLUE GROOVE
 CONDITIONS: SOFT DIRT CLAY WET DUSTY
 OTHER: _____

FRONT TIRES

TIRE: _____
 COMPOUND: _____
 INSERT: _____
 WHEEL: _____

REAR TIRES

TIRE: _____
 COMPOUND: _____
 INSERT: _____
 WHEEL: _____

BATTERY PLACEMENT

BATTERY: _____
 PLACEMENT: _____

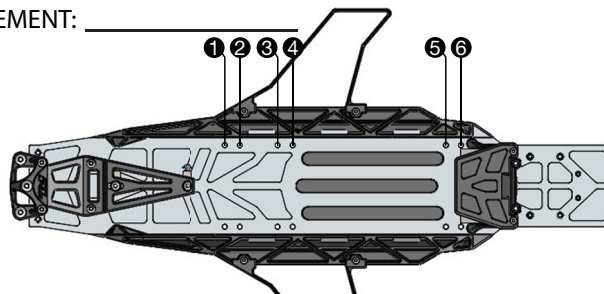

TRANSMISSION SETTINGS

PINION: _____
 SPUR GEAR: _____
 DIFF. OIL: _____

NOTES

For complete step-by-step instructions
 visit PROLINERACING.com

PRO-LINE

PRO-LINE[®]

Pro-Line Racing
201 W. Lincoln St.
Banning, CA 92220

ProLineRacing.com

1-800-899-RACE (7223)

customerservice@prolinerracing.com



facebook.com/prolinerracing
@prolinerracing