

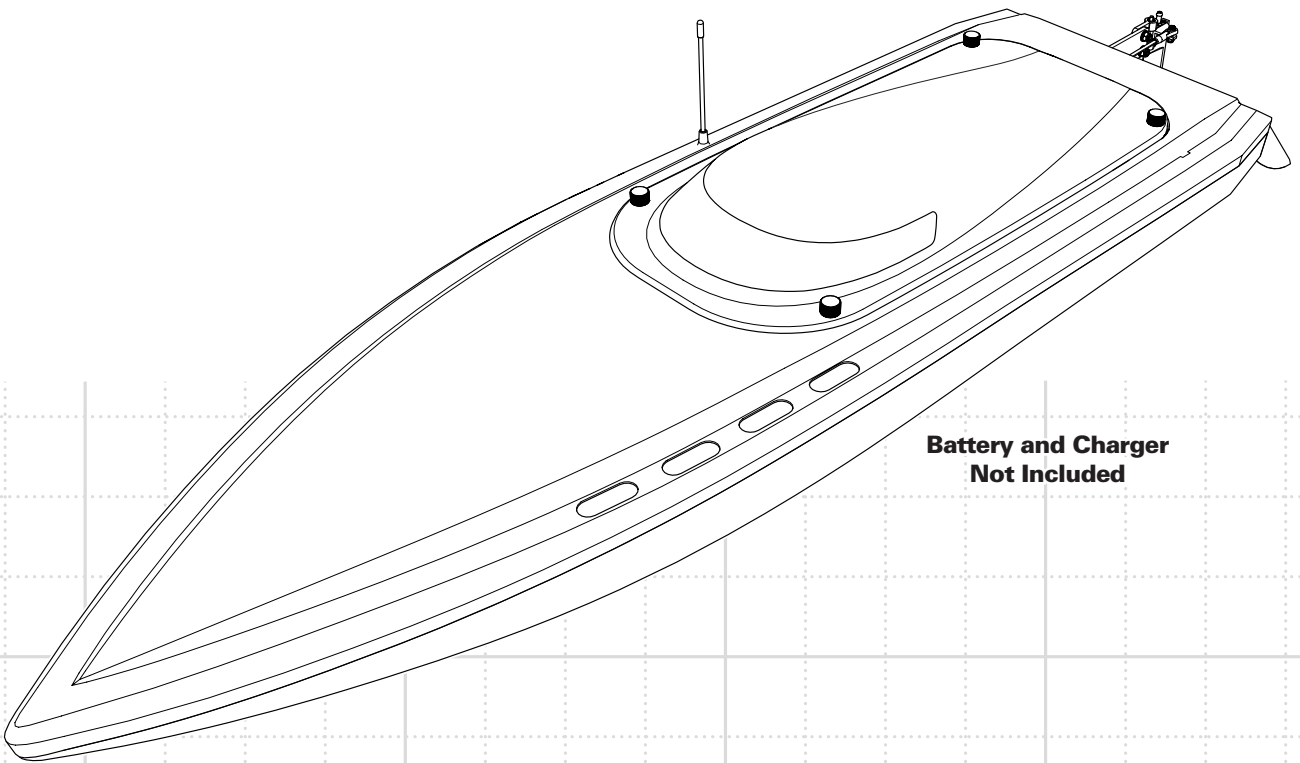

**PROBOAT™**  
ProBoatModels.com

# **SONICWAKE®**

## **36-INCH SELF-RIGHTING DEEP-V BRUSHLESS RTR**



**Battery and Charger  
Not Included**

Scan the QR code and select the Manuals and Support quick links from the product page for the most up-to-date manual information.  
Scannen Sie den QR-Code und wählen Sie auf der Produktseite die Quicklinks Handbücher und Unterstützung, um die aktuellsten Informationen zu Handbücher.  
Scannez le code QR et sélectionnez les liens rapides Manuals and Support sur la page du produit pour obtenir les informations les plus récentes sur le manuel.  
Scannerizzare il codice QR e selezionare i Link veloci Manuali e Supporto dalla pagina del prodotto per le informazioni manuali più aggiornate.



**PRB08032V2**

**Owners Manual • Bedienungsanleitung  
Manuel de l'utilisateur • Manuale dell'utente**

**HORIZON®**  
H O B B Y

## NOTICE

All instructions, warranties and other collateral documents are subject to change at the sole discretion of Horizon Hobby, LLC. For up-to-date product literature, visit [www.horizonhobby.com](http://www.horizonhobby.com) or [www.towerhobbies.com](http://www.towerhobbies.com) and click on the support or resources tab for this product.

## MEANING OF SPECIAL LANGUAGE

The following terms are used throughout the product literature to indicate various levels of potential harm when operating this product:

**WARNING:** Procedures, which if not properly followed, create the probability of property damage, collateral damage, and serious injury OR create a high probability of superficial injury.

**CAUTION:** Procedures, which if not properly followed, create the probability of physical property damage AND a possibility of serious injury.

**NOTICE:** Procedures, which if not properly followed, create a possibility of physical property damage AND little or no possibility of injury.

 **WARNING:** Read the ENTIRE instruction manual to become familiar with the features of the product before operating. Failure to operate the product correctly can result in damage to the product, personal property and cause serious injury.

This is a sophisticated hobby product and NOT a toy. It must be operated with caution and common sense and requires some basic mechanical ability. Failure to operate this Product in a safe and responsible manner could result in injury or damage to the product or other property. This product is not intended for use by children without direct adult supervision. Do not use with incompatible components or alter this product in any way outside of the instructions provided by Horizon Hobby, LLC. This manual contains instructions for safety, operation and maintenance. It is essential to read and follow all the instructions and warnings in the manual, prior to assembly, setup or use, in order to operate correctly and avoid damage or serious injury.

**Age Recommendation: Not for children under 14 years. This is not a toy.**

## Safety Precautions and Warnings

As the user of this product, you are solely responsible for operating in a manner that does not endanger yourself and others or result in damage to the product or the property of others.

- When handling and/or transporting your boat, always pick up the boat from the front, keeping all moving parts pointed away from you.
- Always keep a safe distance in all directions around your model to avoid collisions or injury. This model is controlled by a radio signal subject to interference from many sources outside your control. Interference can cause momentary loss of control.
- Always operate your model in open spaces away from full-size vehicles, traffic and people.
- Always carefully follow the directions and warnings for this and any optional support equipment (chargers, rechargeable battery packs, etc.).
- Always keep all chemicals, small parts and anything electrical out of the reach of children.
- Always avoid water exposure to all equipment not specifically designed and protected for this purpose. Moisture causes damage to unprotected electronics.
- Never place any portion of the model in your mouth as it could cause serious injury or even death.
- Never operate your model with low transmitter batteries.

## Water-Resistant Boat with Waterproof Electronics

Your new Horizon Hobby boat has been designed and built with a combination of waterproof and water-resistant components to allow you to operate the product in calm, fresh water conditions.

While the entire boat is highly water-resistant, it is not completely waterproof and your boat should NOT be treated like a submarine. The various electronic components used in the boat, such as the ESC, servo(s) and receiver are waterproof, however, most of the mechanical components are water-resistant and require additional maintenance after use.

Metal parts, including the bearings, pins, screws and nuts, propeller, rudder, rudder mounts, prop struts, as well as the contacts in the electrical cables, will be susceptible to corrosion if additional maintenance is not performed after running in wet conditions. To maximize the long-term performance of your boat and to keep the warranty intact, the procedures described in the **WET CONDITIONS MAINTENANCE** section must be performed regularly.

 **CAUTION:** Failure to exercise caution while using this product and complying with the following precautions could result in product malfunction and/or void the warranty.

## General Precautions

- Read the **WET CONDITIONS MAINTENANCE** procedures and make sure that you have all the tools you will need to properly maintain your boat.
- Not all batteries can be used in wet conditions. Consult the battery manufacturer before use. Caution should be taken when using Li-Po batteries in wet conditions.
- Most transmitters are not water-resistant. Consult your transmitter's manual or the manufacturer before operation.
- Never operate your transmitter or boat when lightning is present.
- Salt water is very conductive and highly corrosive. If you choose to run your boat in salt water, immediately rinse the boat in fresh water after each use. Operating your boat in salt water is at the sole discretion of the modeler.

## Wet Conditions Maintenance

- Drain any water that has collected in the hull by removing the drain plug or canopy and tilting the boat in the appropriate direction to drain the water.

 **CAUTION:** Always keep hands, fingers, tools and any loose or hanging objects away from rotating parts.

- Remove the battery pack(s) and dry the contacts. If you have an air compressor or a can of compressed air, blow out any water that may be inside the recessed connector housings.
- Remove all moving parts. Dry and lubricate parts after every 30 minutes of operation or if the boat becomes submerged.

**NOTICE:** Never use a pressure washer to clean your boat.

- Use an air compressor or a can of compressed air to dry the boat and help remove any water that may have gotten into small crevices or corners.
- Spray the bearings, fasteners and other metal parts with a water-displacing light oil or lubricant.
- Let the boat air dry before you store it. Water (and oil) may continue to drip for a few hours.

## Box Contents

- Pro Boat® Sonicwake® V2 36-Inch Self-Righting Deep V RTR (PRB08032V2T1/T2)
- Spektrum™ Firma Smart 120A Brushless Marine ESC 3-6S (SPMXME1120)
- Spektrum™ SR315 DSMR® 3-Channel Sport Receiver (SPMSR315)
- Spektrum™ 9KG Waterproof Servo (SPMS605)
- Spektrum™ SLT3™ 3-Channel Transmitter (SPMSLT350)
- Spektrum Firma 1900KV Marine Motor (SPMXMM3300)

## Recommended Tools and Materials

- Needle nose pliers
- Paper towel
- Rubbing alcohol
- Open-end wrench: 10mm (2)
- Nut driver: 4mm, 5.5mm, 8mm
- Hex wrench: 1.5mm, 2mm, 2.5mm, 3mm
- Clear tape (DYNAM0102)
- Pro Boat® Marine Grease and Gun
- Hook and Loop Tape Set, WP (4pcs)
- Clean towels
- CA or Epoxy Glue
- Ball driver: 2.5mm

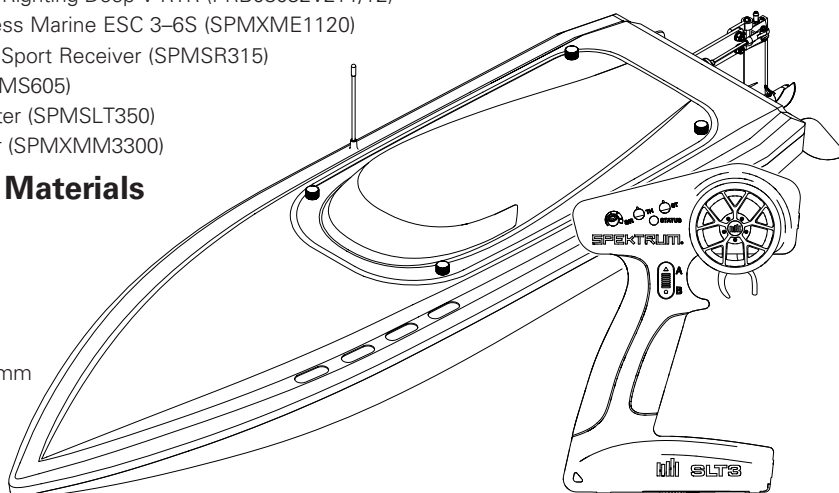

## Specifications

**Length** 36 in. (914.4mm)

**Height** 6.75 in. (171.45mm)

**Beam** 11.0 in. (279.4mm)

### Hull

**Material** Polycarbonate

### Recommended

**Battery** (2) 11.1V 5000mAh 3S 100C Smart Hardcase LiPo Battery: IC5 (SPMX50003S100H5) (sold separately) are required to operate the boat.

6.75 in.  
171.45mm

11.0 in.  
279.4mm

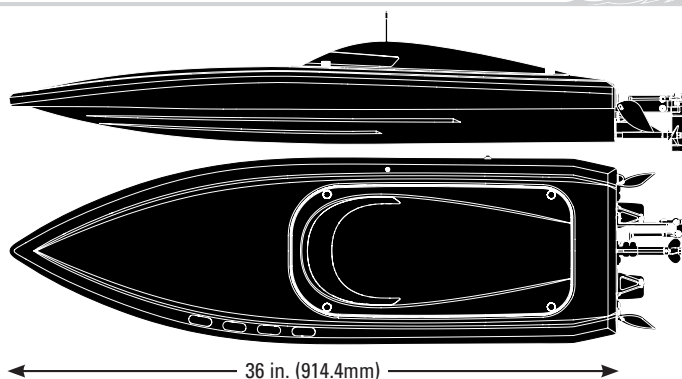

## Table of Contents

Safety Precautions and Warnings .....	2	Drivetrain Lubrication.....	9
Water-Resistant Boat with Waterproof Electronics .....	2	Water Cooling System.....	9
General Precautions.....	2	General Information .....	10
Wet Conditions Maintenance.....	2	SLT Binding.....	10
Box Contents .....	3	DSMR/DSM2 Binding.....	10
Recommended Tools and Materials .....	3	Servo Travel.....	10
Specifications.....	3	Failsafe .....	11
Transmitter Functions.....	4	ESC and Transmitter Calibration .....	11
Antenna Tube Installation .....	4	Programming with the Smart Programmer Box .....	11
Battery Pack Installation.....	5	Operation .....	11
Low Voltage Cutoff (LVC) .....	5	Troubleshooting Guide .....	12
Control Check.....	5	2-Year Limited Warranty.....	13
Getting Started.....	6	Warranty and Service Contact Information .....	14
When You Are Finished.....	6	FCC Information.....	15
Boating Tips.....	7	IC Information .....	15
Self-Righting.....	7	Compliance Information for the European Union.....	15
Maintenance .....	7	Replacement Parts.....	58
Propeller Service.....	7	Optional Parts.....	59
Trim Tab Adjustment.....	8		

## Transmitter Functions

### A. Throttle Trim

Adjusts the throttle neutral point

### B. Steering Trim

Adjusts the steering center point. Normally, the steering trim is adjusted until the vehicle tracks straight.

### C. LED

- **Solid red lights:** Indicates the power is ON and adequate battery power
- **Flashing red lights:** Indicates the battery voltage is critically low. Replace batteries

### D. Steering Wheel

### E. Throttle/Brake

### F. Steering Rate

On-The-Fly knob for travel adjustment on the steering

### G. Channel 3

3 position momentary switch, middle position is neutral  
For programming press up for A button, press down for B button

### H. Throttle Limit

Limits throttle output to 50/75/100%  
Select 50% or 75% for less experienced drivers or when you are driving the vehicle in a small area.

### I. Throttle (TH) Servo Reversing

Move the switch to reverse the throttle channel

### J. Steering (ST) Servo Reversing

Move the switch to reverse the steering channel

### K. Power Button

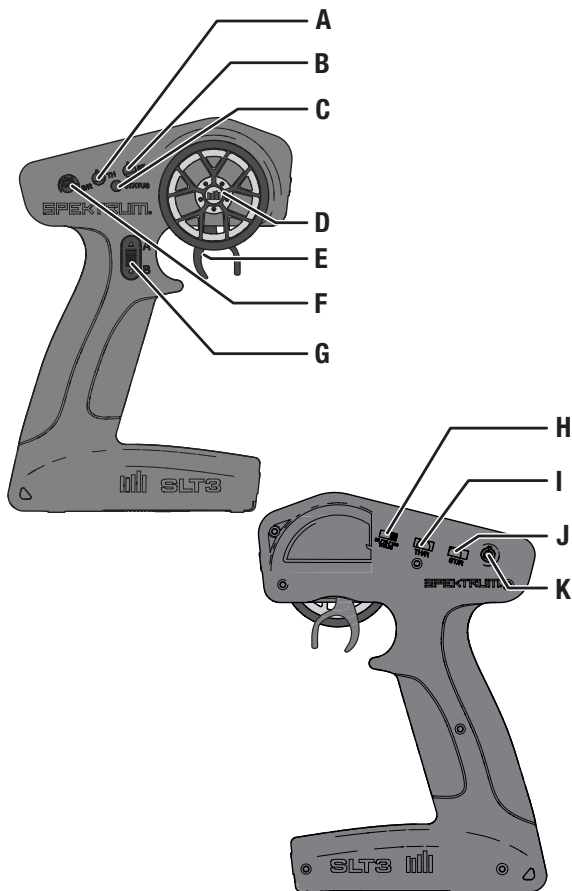

## Installing the Transmitter Batteries

This transmitter requires 4 AA batteries.

1. Remove the battery cover from the transmitter.
2. Install the batteries as shown.
3. Install the battery cover.

**CAUTION:** Never remove the transmitter batteries while the model is powered ON. Loss of model control, damage, or injury may occur.

**CAUTION:** If using rechargeable batteries, charge only rechargeable batteries. Charging non-rechargeable batteries may cause the batteries to burst, resulting in injury to persons and/or damage to property.

**CAUTION:** Risk of explosion if battery is replaced by an incorrect type. Dispose of used batteries according to national regulations.

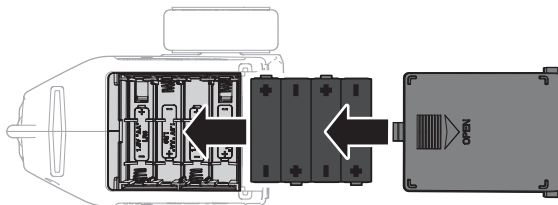

## Antenna Tube Installation

Install the receiver antenna in the tube as shown. Do not bend end of antenna over antenna tube and place cap over it. The antenna does not have to be outside of the tube to operate properly.

Keep the end of the antenna above the boat's waterline to get the best transmitter reception. Apply clear tape (DYNM0102), if desired.

**NOTICE:** Do not cut or kink the receiver antenna or damage may result.

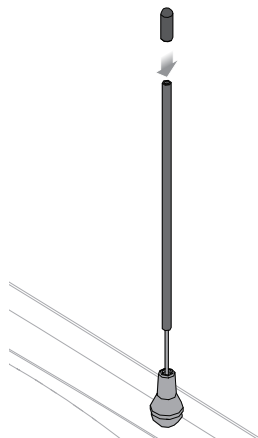

## Battery Pack Installation

1. Loosen the 4 canopy screws.
2. Carefully lift the canopy from the hull.
3. Install the batteries in the battery tray.
4. Connect the battery packs to the ESC power connectors.
5. Before placing your boat in the water, secure the canopy on the hull. Apply clear tape (DYNM0102), if desired.

**TIP:** Place the canopy flat onto the hull and secure the two front screws simultaneously. Then secure the two rear screws simultaneously. This helps prevent cross threading and damage to the thumbscrews and/or threaded inserts.

**TIP:** Begin with the batteries as far forward as possible, moving them back ½ inch (13mm) at a time toward the stern until the boat reaches maximum speed.

### Positioning the Battery Packs

- **Toward the Bow:** In rough water or strong wind conditions, place the battery packs at the front of the battery trays to ensure the greatest stability.
- **Centered:** Smooth water and calm winds may allow you to move the battery packs rear-ward in the hull to allow the bow to ride higher and increase speed. Be aware that positioning the batteries farther aft increases the likelihood of the boat blowing over at speed or becoming unstable.
- **Toward the Stern:** Positioning the batteries all the way back in their trays may provide higher top speeds but can cause instability. Experiment with this position only in very calm conditions while closely monitoring the hull's attitude as you increase speed.

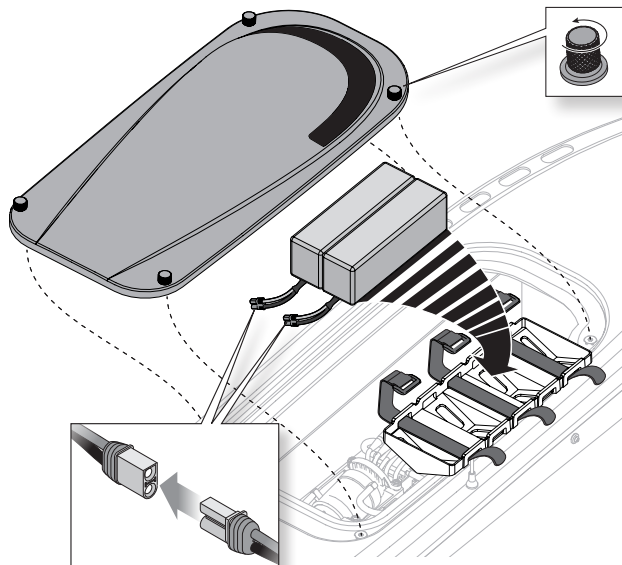

## Low Voltage Cutoff (LVC)

The factory default setting for the LVC in the ESC included with your boat is set at 3.2V per cell. Discharging a Li-Po battery below 3V per cell may damage your battery. The included ESC protects the boat battery from over-discharge using Low Voltage Cutoff (LVC). Before the battery charge decreases too much, LVC removes power supplied to the motor.

The boat drastically slows or stops completely once LVC is activated. Releasing the throttle and reapplying it will provide a limited amount of power to safely return the boat to shore. Repeated use after LVC is activated will damage the batteries.

Once LVC has been activated, the ESC status light will flash red continuously indicating that the ESC is in LVC mode.

**NOTICE:** Repeated operation to LVC will damage the battery.

LVC can activate prematurely if you use (1) low C-rated batteries or (2) old, worn, and/or weak batteries.

The average run time—using the recommended batteries (SPMX50003S100H5)—is between 3–4 minutes at non-stop, open throttle. Limited run time may indicate worn or weak batteries.

**TIP:** If you've installed freshly charged batteries, and LVC activates within the first minute of operation, replace your worn or weak batteries with the recommended batteries.

**TIP:** Monitor your boat battery's voltage before and after boating by using a Li-Po Cell Voltage Checker (DYN4071, sold separately).

Disconnect and remove the Li-Po battery from the boat after use to prevent trickle discharge. Charge your Li-Po battery to half capacity before storage. During storage, make sure the battery charge does not fall below 3V per cell. LVC does not prevent the battery from over-discharge during storage.

## Control Check

**IMPORTANT:** Perform a control check at the beginning of each boating session, after repair, or after installation of new batteries.

Ensure the receiver antenna is extended properly and all batteries are fully charged.

1. Power ON the transmitter and the boat.  
**Do not install the boat canopy.**
2. Place the boat securely on the boat stand.

**NOTICE:** Do not operate the motor longer than 20 seconds without water-cooling circulation or damage may result.

3. Check steering and throttle on the transmitter.

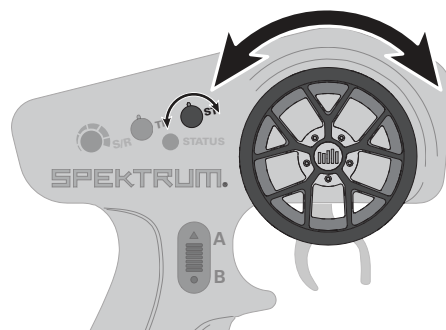

## Getting Started

1. Power on the transmitter.
2. Connect the two batteries to the IC5® connectors on the ESC.
3. Power on the ESC switch. The ESC arming tones will sound.
4. Test the transmitter's control of the boat with the boat on the display stand.
5. Remove the rudder cover before operating the boat.

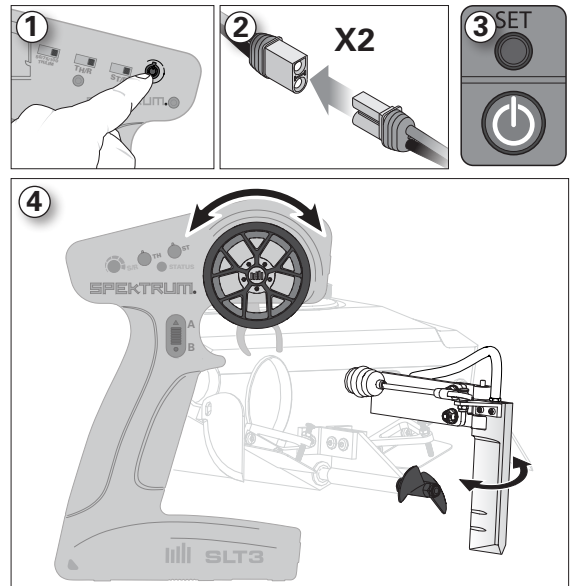

## When You Are Finished

1. Power off the ESC.
  2. Power off the transmitter.
  3. Disconnect and remove the battery from the boat.
- TIP:** Always remove the canopy before storage or moisture may allow mold and mildew to grow in the boat.
4. Drain water from inside the hull using the drain plug.
  5. Fully dry the inside and outside of the boat, including the water cooling lines and jacket around the motor. Carefully dry all battery, motor and receiver connectors by removing one at a time and reinstalling.
  6. Remove the hatch before storing your boat.
  7. Repair any damage or wear to the boat.
  8. Lubricate the flex shaft using Pro Boat® Marine Grease (DYNE4200 or DYNE4201).
  9. Note the lessons learned from the trimming of your boat, including water and wind conditions.
  10. Replace the rudder cover to protect the rudder's sharp points.

**NOTICE:** When you are finished boating, never leave the boat in direct sunlight or in a hot, enclosed area such as a car. Doing so can damage the boat.

**NOTICE:** Using a larger propeller, or one with more pitch than the one included (on 6S [22.2v]), may damage the electronics and battery packs.

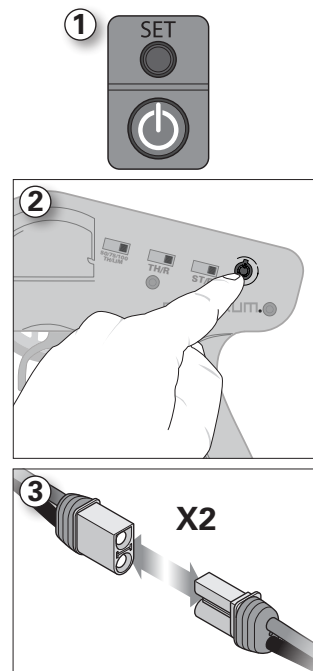

## Boating Tips

During the first run, we recommend calm wind and water conditions to ensure that the boat is properly set up. Maximum speeds of 50 MPH/+ can be achieved once you have set up the boat for your specific conditions. Top speed will also be determined by the battery's ability to efficiently deliver power to the motor via the ESC.

Consult local laws and ordinances before choosing a location to pilot your boat.

1. Carefully place the boat in the water.
2. Operate the boat at slow speeds near the shoreline. Avoid objects in the water at all times. When the boat is moving forward, ensure water flows out of the coolant outlet.
3. Once you are comfortable operating the boat at slow speeds, it is safe to operate the boat farther from the shore at higher speeds.
4. Bring the boat back to shore when the motor starts to pulse.

**NOTICE:** Never operate your boat in less than 12 inches (30.5 cm) of water.



**CAUTION:** Never attempt to retrieve a downed boat by swimming. If you need to retrieve your boat from the water, use fishing equipment or another boat.

**NOTICE:** When running at full speed in choppy water, the propeller may exit and re-enter the water repeatedly and very quickly, subjecting the propeller and drive shaft to some stress. Frequent stress may damage the propeller and drive shaft.

In rough water and windy conditions, consider:

- mounting the batteries further forward for added stability
- adjusting the struts downward to prevent the boat from overturning

### Avoid boating near:

- watercraft
- people (swimming areas, fishing areas)
- stationary objects
- waves and wakes
- rapidly moving water
- wildlife
- floating debris
- overhanging trees
- vegetation

## Self-Righting

The self-righting feature uses a water ballast system. The ballast works as a controlled breach in the hull. As the boat to sink, while the air trapped inside the hull causes enough buoyancy to right the boat.

The boat will self-right automatically, using water ballast.

Once the boat is upright, it will lean to one side. Apply full throttle. The trapped water will be forced out of the ballast tanks by the boat's forward momentum.

**IMPORTANT:** Applying throttle during the self-righting process may prevent the boat from turning over.

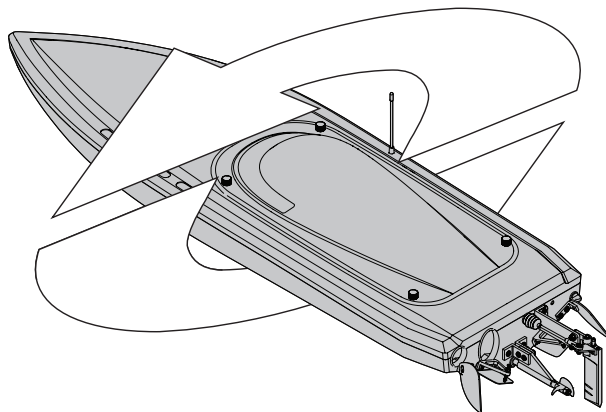

## Maintenance

### Propeller Service

1. Use an 8mm nut driver to loosen the nut (A) from the driveshaft (B).
2. Remove the nut and propeller (C) from the driveshaft.
3. Inspect the propeller for any damage or wear and replace as necessary.
4. Assemble in reverse order. Correctly align the propeller with the drive dog on the driveshaft.

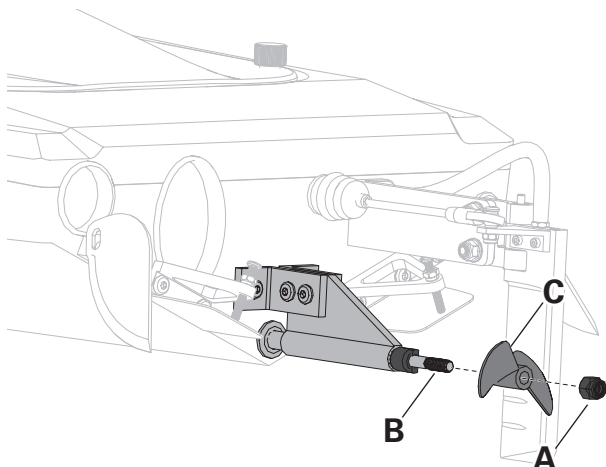

## Trim Tab Adjustment

The trim tabs come installed from the factory to stabilize the boat as it rides across the water. They are set for consistent performance and stability in most water conditions. However, you can tune out chime walk or porpoise effect by adjusting the trim tabs so they are at least 1–1.5 mm below the ride surface of the boat.

Adjusting the tabs up or down allows the boat to come in more or less contact with the water, resulting in either a smooth, planted ride or a fast, loose ride.

1. Position a ruler parallel to the keel on the right side of the right trim tab, allowing the ruler to extend past the trim tab.
2. To adjust the angle of the trim tab, loosen the locking nut on the adjustment screw, and then tighten the screw.
3. Use a ruler to measure and record the tab adjustment. Measure the length of the bolt head to the base of aluminum trim tab arm.
4. Record the position of the trim tab against the ruler's straight edge after adjusting the trim tab.

5. Tighten the adjustment lock nut to prevent further movement of the adjustment screw.
6. Repeat this process on the left trim tab, ensuring the trim tab panels are either perpendicular to or parallel to the bottom of the boat.

**NOTICE:** The trim tabs should be the same distance above or below the boat's ride surface. Adjusting one trim tab more than the other can cause the boat to behave erratically.

**NOTICE:** If the boat rolls or flips at full speed, the trim tabs or turn fins may have moved or flexed. Immediately return the boat to shore for inspection.

**NOTICE:** It may be necessary to bend the trim tabs to remove any down force applied to the trim tabs. This should only be done if there is a gap between the adjustment screw and trim tab plate.

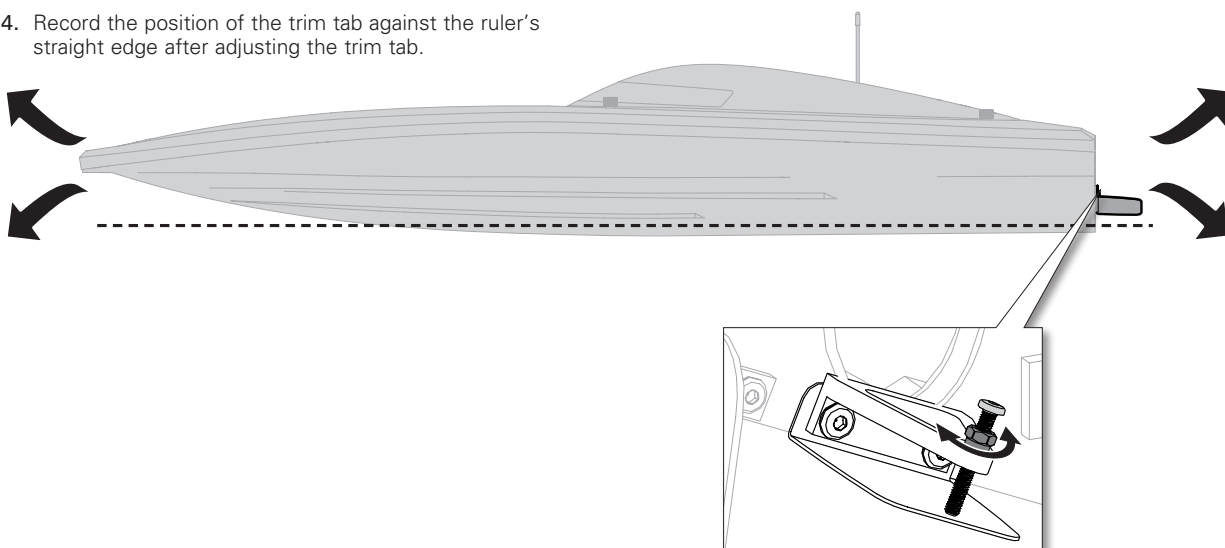



## Drivetrain Lubrication

Always replace the drivetrain parts when they are damaged or show visible wear or injury and damage may result.

Lubricating the drive shaft is vital to the life of the drivetrain. The lubricant also acts as a water seal, keeping water from entering the hull through the stuffing tube.

Lubricate the drive shaft and all moving parts after every 20 minutes of operation.

1. In the hull, use two 10 mm open-end wrenches to loosen the motor coupler.
2. Slide the drive shaft out from the stuffing tube and drive strut at the rear of the boat.
3. Wipe the old lubricant and material from the drive shaft.
4. Apply a liberal amount of lubrication to the flex shaft and spread it around the entire shaft. Ensure enough lubrication is on the shaft to prevent any dry areas.

**NOTICE:** When lubricating the flex shaft, do not lubricate the first 20mm of the flex shaft. If grease gets into the motor coupler, it may cause the flex shaft to slip inside of the coupler, thereby damaging it and requiring replacement.

5. Carefully reinstall the drive shaft. Rotate it to spread the grease on the inside of the stuffing tube, ensuring that there is a 1–2mm gap between the propeller strut and the drive dog. This will allow space for the shaft as it shrinks under load. Without space, the drive dog could damage the aluminum propeller strut.

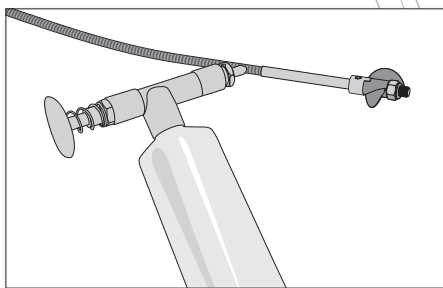

**NOTICE:** Ensure the flex shaft is installed correctly. Installing the flex shaft incorrectly may result in irreparable damage to the boat.

6. Carefully push the flex shaft into the motor coupler, making sure the grease does not carry into the coupler.
7. Tighten the coupler using two 10mm open-end wrenches.

**NOTICE:** Running the boat in saltwater could cause some parts to corrode. If you run the boat in saltwater, rinse it thoroughly in freshwater after each use, lubricate the drive system, and flush the coolant system.

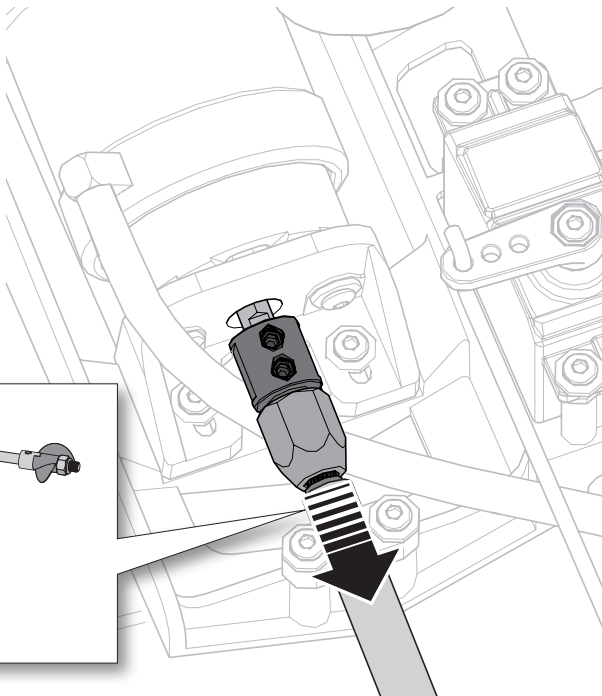

## Water Cooling System

If water does not stream out of the right-side water outlet while the boat is moving forward, immediately stop the boat and clean the obstruction from the water-cooling system.

1. Disassemble and clean the water cooling system to remove blockage and prevent overheating.
2. Replace any damaged parts.

**IMPORTANT:** Ensure that the water cooling exit ports are securely attached to the outside of the hull. Failure to inspect this can result in excess water entering the hull.



**CAUTION:** Running a battery with less than 11.1V will not provide enough momentum to engage the water-cooling system and will cause damage to the electronics due to excessive heat.

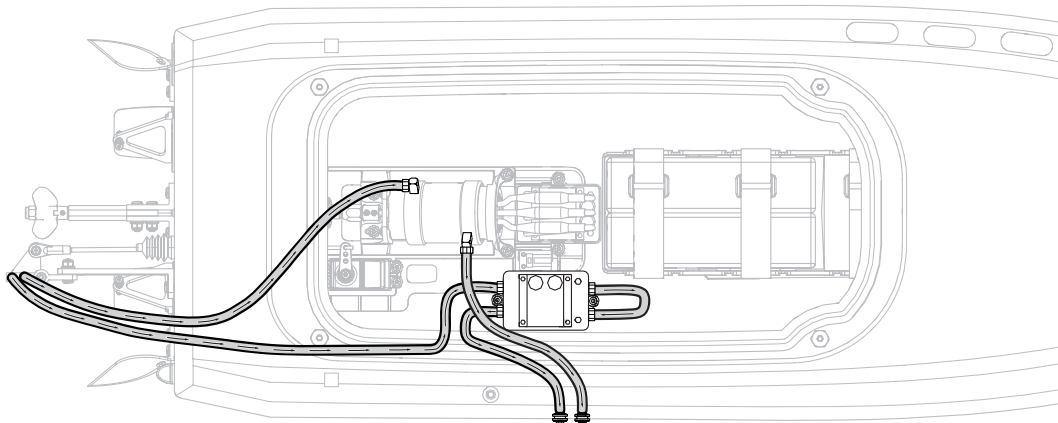

## General Information

### Receiver Antenna

The SR315 receiver features a coaxial antenna design for easy installation in almost any model. The last 1 inch (32mm) on the tip of the antenna is the active portion of the antenna. Install the antenna so the active portion is positioned as high as possible in the vehicle and not "in the shadow" of any carbon fiber or metal. The receiver case can accept an antenna tube directly, making optimal antenna placement easy (antenna tube not included).



**WARNING:** Do not kink, cut or damage the antenna wire. The antenna is made of a coaxial wire; if the outer sheath becomes damaged, the receiver will not work properly. If the antenna is damaged in any way, replace the antenna before attempting to use the receiver.

### SLT Binding

Binding is the process of programming the receiver to recognize the GUID (Globally Unique Identifier) code of a single specific transmitter.

1. Power ON the receiver, press the bind button three times quickly (within 1.5 seconds of the first button press). The LED will begin to flash with a pause.
2. Set the trims and control positions at the desired failsafe settings, and power ON the SLT3 transmitter.
3. When the LED on the SLT3 transmitter and receiver remain lit, binding is complete.

You must rebind when:

- Different failsafe positions are desired e.g., when throttle or steering reversing has been changed.
- Binding the receiver to a different transmitter.

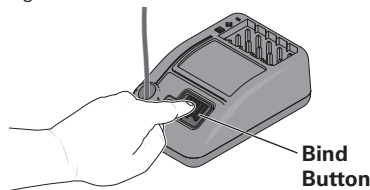

### DSMR/DSM2 Binding

#### Standard Mode (default)

If loss of signal occurs, SmartSafe™ technology moves the *throttle channel* to its designated failsafe position (low throttle, neutral trigger) that was set during binding. All other channels hold their last position. When the receiver detects signal from the transmitter, normal operation resumes.

#### To Bind in Standard Mode:

1	Center the throttle trim knob on the transmitter and ensure the throttle trigger is at the neutral position.
2	Push and hold the receiver bind button.
3	Power on the receiver. The receiver LED will flash rapidly.
4	Release the receiver bind button.
5	Push and hold the transmitter bind button.
6	Power on the transmitter. The transmitter power LED will flash and glow solid when binding is complete.
7	Release the transmitter bind button.

### Servo Travel

The servo travel on the Steering and Throttle channels can be adjusted through a special programming mode in the transmitter.

1. Begin with the transmitter binding process to the receiver complete. Power ON the receiver.
2. Hold full right and full brake while powering the transmitter ON to put the transmitter into programming mode. The LED on the transmitter will flash 4 times to indicate it is in programming mode.
3. Turn and hold the wheel full left to set the travel limit for that direction, Press the A button to increase travel, press the B button to reduce travel. The LED will flash once with every change. Return the wheel to center to set the travel value.

4. Turn the wheel to the right and repeat the process to set the steering travel to the right.
5. For electric vehicles, power the Transmitter OFF to save the settings. Calibrate your ESC to the default throttle travel.
6. For fuel powered vehicles, set the throttle travel without the engine running; After setting steering travel, you can set throttle travel with the same process. Pull and hold full throttle, adjust travel with the A and B buttons, return to center to set the value.
7. Push full brake, adjust travel with the A and B buttons, return to center
8. Power the transmitter OFF to save the values.

**IMPORTANT:** If the value has reached the maximum or minimum that can be accepted, the LED will not flash with further input.

## Failsafe

In the unlikely event that the radio connection is lost during use, the receiver will drive the servo and ESC to their pre-programmed failsafe positions (normally no throttle and straight steering).

If the receiver is powered on before powering on the transmitter, the receiver will enter this failsafe mode. When the transmitter is powered on, normal control is resumed.

## ESC and Transmitter Calibration

1. Begin with the transmitter and receiver binding complete.
2. Set your transmitter's throttle channel to 100% travel and trim to neutral.
3. Turn on your transmitter and connect a battery to the ESC but don't power it on.
4. Press and hold the Set button while turning on the ESC. When the red LED begins to flash, release the Set button. The ESC will enter programming mode if the button is pressed for more than three seconds.
5. Leave the throttle trigger at the neutral position, then press and release the Set button. The red LED will stop flashing, the green LED will flash one time and the motor will make a tone to indicate the neutral position has been accepted.
6. Hold the throttle trigger at the full throttle position then press and release the Set button. The green LED will flash twice and the motor will make two tones to indicate the full throttle position has been accepted.
7. Hold the throttle trigger at the full brake position then press and release the Set button. The green LED will flash three times and the motor will make three tones to indicate the full brake position has been accepted.

**TIP:** The red LED should be flashing when the ESC enters calibration mode. If the green LED is flashing the ESC is in programming mode.

The motor will operate normally after calibration is completed.

## Programming with the Smart Programmer Box

1. Unplug the fan and connect the programming lead to the fan port.
2. Connect a battery to the ESC.
3. Power on the box and select the parameter with the SELECT button.
4. Change the values of the selected parameter with the EDIT button.
5. Press the SAVE button to save the changes. The ESC requires a power cycle to implement the saved changes.

*The black-shaded setting is the factory default*

Programmable Items	Parameter Options								
	1	2	3	4	5	6	7	8	9
Running Mode	Forward Only	Forward/ Backward							
Li-Po Cells	Auto Calc.	3S	4s	5s	6s	7s			
Low Voltage Cutoff	Disabled	2.8V/Cell	3.0V/Cell	3.2V/Cell	3.4V/Cell				
Timing	0°	3.75°	7.5°	11.25°	15°	18.5°	22.5°	26.5°	

## Operation

1. Connect a battery to the ESC.
2. Leave the transmitter throttle at neutral and press the On/Off button on the ESC to turn it on. The ESC will cause the motor to make several tones.
3. Press the On/Off button or unplug the battery to turn off the ESC.

The number of tones indicates (1) the ESC is in operation (2) the LiPo cell count detected and (3) the ESC is in a ready-to-use state.

**NOTICE:** Do not leave a battery connected with the ESC turned off for extended periods of time. Always unplug the battery for storage or the battery may be damaged.

LED Indicator	LED Code
ESC turned On, LED indicator is Off	Throttle trigger is in the neutral zone
Red LED illuminated	ESC is operating in forward, reverse or brake
Red and Green LED illuminated	ESC is at full throttle, full brake, or full reverse
LED flashes red with short single pulses	LVC protection activated
LED flashes green with short single pulses	The ESC is in thermal shutoff mode
LED flashes green with three short pulses repeating	The ESC has exceeded the continuous current limit
LED flashes green with four short pulses repeating	The ESC has failed the self test
LED flashes green with five short pulses repeating	Capacitor temperature has been exceeded



## Troubleshooting Guide

Problem	Possible Cause	Solution
Boat will not respond to throttle but responds to other controls	Throttle channel is reversed	Reverse throttle channel on transmitter
Extra noise or extra vibration	Damaged propeller, shaft or motor	Replace damaged parts
	Propeller is out of balance	Balance or replace propeller
	Boat squeals or makes a high pitch sound when applying power to motors	Lubricate flex shafts
Reduced runtime or boat underpowered	Boat battery charge is low	Completely recharge battery
	Boat battery is damaged	Replace boat battery and follow battery instructions
	Blocking or friction on shaft or propeller	Disassemble, lubricate and correctly align parts
	Boat conditions may be too cold	Make sure the battery is warm (above 10° C [50° F]) before use
	Battery capacity may be too low for conditions	Replace battery or use a larger capacity battery
	Drive dog is too near the stuffing tube	Loosen drive shaft side of the motor coupling and move drive shaft small amount back
	Too little lubrication on drive shaft	Fully lubricate drive shaft
	Vegetation or other obstacles block the rudder or propeller	Remove vegetation or obstacles from rudder or propeller
Motor couplers are loose	Tighten motor couplers and ensure the coupler is free of lubrication	
Boat will not bind (during binding) to transmitter	Transmitter is too near boat during binding process	Move powered transmitter a few feet from boat, disconnect and reconnect battery to boat
	Boat or transmitter is too close to large metal object, wireless source or another transmitter	Move the boat and transmitter to another location and attempt binding again
	Another compatible transmitter is powered on within range of the receiver	Power off all compatible transmitters except the one you are trying to bind
	Incorrect binding protocol set	Verify binding procedure and use SLT binding for stock radio. If using a DSMR or DSM2 utilize the standard binding procedure listed in the manual
	Boat battery/Transmitter battery charge is too low	Replace/recharge batteries
	ESC switch is off	Power on ESC switch
Boat will not connect (after binding) to transmitter	Transmitter is too near boat during connecting process	Move powered transmitter a few feet from boat, disconnect and reconnect battery to boat
	Boat or transmitter is too close to large metal object, wireless source or another transmitter	Move boat or transmitter to another location and attempt to connect again
	Boat battery/transmitter battery charge is too low	Replace/recharge batteries
	ESC switch is off	Power on ESC switch
Boat tends to dive in the water or takes on water	Boat hull is not completely closed	Dry out the boat and ensure the hatch is fully closed on the hull before returning the boat to the water
	Trim tabs are adjusted too deep	Adjust trim tabs up
	Center of gravity is too far forward	Move batteries back in the hull
Boat tends to turn one direction	Rudder or rudder trim is not centered	Repair rudder or adjust rudder and rudder trim for straight running when control is at neutral
	Break away screw is damaged or broken	Replace damaged screw
	ESC may require full throttle range calibration	Calibrate the ESC
Rudder does not move	Rudder, linkage or servo damage	Replace or repair damaged parts and adjust controls
	Steering servo wire is damaged or connections are loose	Do a check of steering servo wires and connections, connect or replace as needed
	Transmitter is not bound correctly	Re-bind
	BEC of the ESC is damaged	Replace ESC
	ESC switch is off	Power on ESC switch
Controls reversed	Transmitter settings are reversed	Do the Control Direction Test and adjust controls on transmitter appropriately
Motor overheats	Blocked water cooler tubes	Clean or replace water tubes

Problem	Possible Cause	Solution
Motor power pulses then motor loses power	ESC uses default soft Low Voltage Cutoff (LVC)	Recharge boat battery or replace battery that is no longer performing
	Weather conditions might be too cold	Postpone until weather is warmer
	Battery is old, worn out or damaged	Replace battery
Boat blows over upon acceleration	Batteries are too far back in the battery tray	Move the batteries forward to adjust the boat's center of gravity
	Struts have too much positive angle, causing the nose of the boat to lift and blow over	Adjust a more neutral or negative strut angle
	Trim Tabs not adjusted, causing the nose of the boat to lift and blow over	Adjust the trim tabs further into the water to keep the nose of the boat in the water and provide additional stability
	Water conditions are too choppy or windy	Adjust the struts downward to drive the bow of the boat down or move the batteries further forward for better weight distribution

## 2-Year Limited Warranty

**What This Warranty Covers** — Horizon Hobby, LLC, (Horizon) warrants to the original purchaser that the product purchased (the "Product") will be free from defects in materials and workmanship for two years from the date of purchase.

**What is Not Covered** — This warranty is not transferable and does not cover (i) cosmetic damage, (ii) damage due to acts of God, accident, misuse, abuse, negligence, commercial use, or due to improper use, installation, operation or maintenance, (iii) modification of or to any part of the Product, (iv) attempted service by anyone other than a Horizon Hobby authorized service center, (v) Product not purchased from an authorized Horizon dealer, or (vi) Product not compliant with applicable technical regulations or (vii) use that violates any applicable laws, rules, or regulations.

OTHER THAN THE EXPRESS WARRANTY ABOVE, HORIZON MAKES NO OTHER WARRANTY OR REPRESENTATION, AND HEREBY DISCLAIMS ANY AND ALL IMPLIED WARRANTIES, INCLUDING, WITHOUT LIMITATION, THE IMPLIED WARRANTIES OF NON-INFRINGEMENT, MERCHANTABILITY AND FITNESS FOR A PARTICULAR PURPOSE. THE PURCHASER ACKNOWLEDGES THAT THEY ALONE HAVE DETERMINED THAT THE PRODUCT WILL SUITABLY MEET THE REQUIREMENTS OF THE PURCHASER'S INTENDED USE.

**Purchaser's Remedy** — Horizon's sole obligation and purchaser's sole and exclusive remedy shall be that Horizon will, at its option, either (i) service, or (ii) replace, any Product determined by Horizon to be defective. Horizon reserves the right to inspect any and all Product(s) involved in a warranty claim. Service or replacement decisions are at the sole discretion of Horizon. Proof of purchase is required for all warranty claims. SERVICE OR REPLACEMENT AS PROVIDED UNDER THIS WARRANTY IS THE PURCHASER'S SOLE AND EXCLUSIVE REMEDY.

**Limitation of Liability** — HORIZON SHALL NOT BE LIABLE FOR SPECIAL, INDIRECT, INCIDENTAL OR CONSEQUENTIAL DAMAGES, LOSS OF PROFITS OR PRODUCTION OR COMMERCIAL LOSS IN ANY WAY, REGARDLESS OF WHETHER SUCH CLAIM IS BASED IN CONTRACT, WARRANTY, TORT, NEGLIGENCE, STRICT LIABILITY OR ANY OTHER THEORY OF LIABILITY, EVEN IF HORIZON HAS BEEN ADVISED OF THE POSSIBILITY OF SUCH DAMAGES. Further, in no event shall the liability of Horizon exceed the individual price of the Product on which liability is asserted. As Horizon has no control over use, setup, final assembly, modification or misuse, no liability shall be assumed nor accepted for any resulting damage or injury. By the act of use, setup or assembly, the user accepts all resulting liability. If you as the purchaser or user are not prepared to accept the liability associated with the use of the Product, purchaser is advised to return the Product immediately in new and unused condition to the place of purchase.

**Law** — These terms are governed by Illinois law (without regard to conflict of law principals). This warranty gives you specific legal rights, and you may also have other rights which vary from state to state. Horizon reserves the right to change or modify this warranty at any time without notice.

### WARRANTY SERVICES

**Questions, Assistance, and Services** — Your local hobby store and/or place of purchase cannot provide warranty support or service. Once assembly, setup or use of the Product has been started, you must contact your local distributor or Horizon directly. This will enable Horizon to better answer your questions and service you in the event that you may need any assistance. For questions or assistance, please visit our website at [www.horizonhobby.com](http://www.horizonhobby.com), submit a Product Support Inquiry, or call the toll free telephone number referenced in the Warranty and Service Contact Information section to speak with a Product Support representative.

**Inspection or Services** — If this Product needs to be inspected or serviced and is compliant in the country you live and use the Product in, please use the Horizon Online Service Request submission process found on our website or call Horizon to obtain a Return Merchandise Authorization (RMA) number. Pack the Product securely using a shipping carton. Please note that original boxes may be included, but are not designed to withstand the rigors of shipping without additional protection. Ship via a carrier that provides tracking and insurance for lost or damaged parcels, as Horizon is not responsible for merchandise until it arrives and is accepted at our facility. An Online Service Request is available at [http://www.horizonhobby.com/content/service-center\\_render-service-center](http://www.horizonhobby.com/content/service-center_render-service-center). If you do not have internet access, please contact Horizon Product Support to obtain a RMA number along with instructions for submitting your product for service. When calling Horizon, you will be asked to provide your complete name, street address, email address and phone number where you can be reached during business hours. When sending product into Horizon, please include your RMA number, a list of the included items, and a brief summary of the problem. A copy of your original sales receipt must be included for warranty consideration. Be sure your name, address, and RMA number are clearly written on the outside of the shipping carton.

**NOTICE:** Do not ship LiPo batteries to Horizon. If you have any issue with a LiPo battery, please contact the appropriate Horizon Product Support office.

**Warranty Requirements** — For Warranty consideration, you must include your original sales receipt verifying the proof-of-purchase date. Provided warranty conditions have been met, your Product will be serviced or replaced free of charge. Service or replacement decisions are at the sole discretion of Horizon.

**Non-Warranty Service — Should your service not be covered by warranty, service will be completed and payment will be required without notification or estimate of the expense unless the expense exceeds 50% of the retail purchase cost.**

By submitting the item for service you are agreeing to payment of the service without notification. Service estimates are available upon request. You must include this request with your item submitted for service. Non-warranty service estimates will be billed a minimum of ½ hour of labor. In addition you will be billed for return freight. Horizon accepts money orders and cashier's checks, as well as Visa, MasterCard, American Express, and Discover cards. By submitting any item to

Horizon for service, you are agreeing to Horizon's Terms and Conditions found on our website [http://www.horizonhobby.com/content/service-center\\_render-service-center](http://www.horizonhobby.com/content/service-center_render-service-center).

**ATTENTION: Horizon service is limited to Product compliant in the country of use and ownership. If received, a non-compliant Product will not be serviced. Further, the sender will be responsible for arranging return shipment of the un-serviced Product, through a carrier of the sender's choice and at the sender's expense. Horizon will hold non-compliant Product for a period of 60 days from notification, after which it will be discarded.**

10/15

## Warranty and Service Contact Information\*

Country of Purchase	Horizon Hobby	Contact Information	Address
United States of America	Horizon Service Center (Repairs and Repair Requests)	<a href="http://servicecenter.horizonhobby.com/RequestForm/">servicecenter.horizonhobby.com/RequestForm/</a>	2904 Research Rd. Champaign, Illinois, 61822 USA
	Horizon Product Support (Product Technical Assistance)	<a href="mailto:productsupport@horizonhobby.com">productsupport@horizonhobby.com</a>	
		877-504-0233	
Sales	<a href="mailto:websales@horizonhobby.com">websales@horizonhobby.com</a>		
	800-338-4639		
EU	Horizon Technischer Service	<a href="mailto:service@horizonhobby.de">service@horizonhobby.de</a>	Hanskampring 9 D 22885 Barsbüttel, Germany
	Sales: Horizon Hobby GmbH	+49 (0) 4121 2655 100	

\*For the most up-to-date customer service contact information, please visit: [www.horizonhobby.com/content/service-center-render-service-center](http://www.horizonhobby.com/content/service-center-render-service-center)

## FCC Information

**FCC ID: BRWSRIRVINGV1**

**FCC ID: BRWSPMSLT300**

This equipment complies with FCC and IC radiation exposure limits set forth for an uncontrolled environment. This equipment should be installed and operated with minimum distance 20cm between the radiator and/or antenna and your body (excluding fingers, hands, wrists, ankles and feet). This transmitter must not be co-located or operating in conjunction with any other antenna or transmitter.

### **Supplier's Declaration of Conformity** **ProBoat Sonicwake 36 V2 Self Righting Deep V** **Brushless, RTR (LOS08032V2)**

This device complies with part 15 of the FCC Rules. Operation is subject to the following two conditions: (1) This device may not cause harmful interference, and (2) this device must accept any interference received, including interference that may cause undesired operation.



**CAUTION:** Changes or modifications not expressly approved by the party responsible for compliance could void the user's authority to operate the equipment.

**NOTE:** This equipment has been tested and found to comply with the limits for a Class B digital device, pursuant to part 15 of the FCC Rules. These limits are designed to provide reasonable protection against harmful interference in a residential installation.

This equipment generates, uses and can radiate radio frequency energy and, if not installed and used in accordance with the instructions, may cause harmful interference to radio communications. However, there is no guarantee that interference will not occur in a particular installation. If this equipment does cause harmful interference to radio or television reception, which can be determined by turning the equipment off and on, the user is encouraged to try to correct the interference by one or more of the following measures:

- Reorient or relocate the receiving antenna.
- Increase the separation between the equipment and receiver.
- Connect the equipment into an outlet on a circuit different from that to which the receiver is connected.
- Consult the dealer or an experienced radio/TV technician for help.

Horizon Hobby, LLC  
2904 Research Rd., Champaign, IL 61822  
Email: [compliance@horizonhobby.com](mailto:compliance@horizonhobby.com)  
Web: [HorizonHobby.com](http://HorizonHobby.com)

## IC Information

**CAN ICES-3 (B)/NMB-3(B)**

**IC: 6157A-SRIRVINGV1**

**6157A-SPMSLT300**

This device contains license-exempt transmitter(s)/receiver(s) that comply with Innovation, Science, and Economic Development Canada's license-exempt RSS(s). Operation is subject to the following 2 conditions:

1. This device may not cause interference.
2. This device must accept any interference, including interference that may cause undesired operation of the device.

## Compliance Information for the European Union

### **EU Compliance Statement:** **ProBoat Sonicwake 36 V2 Self Righting Deep V** **Brushless, RTR (LOS08032V2)**

Hereby, Horizon Hobby, LLC declares that the device is in compliance with the following: EU RED 2014/53/EU; RoHS 2 Directive 2011/65/EU; RoHS 3 Directive - Amending 2011/65/EU Annex II 2015/863.

The full text of the EU declaration of conformity is available at the following internet address: <https://www.horizonhobby.com/content/support-render-compliance>.

**NOTE:** This product contains batteries that are covered under the 2006/66/EC European Directive, which cannot be disposed of with normal household waste. Please follow local regulations.

### **Wireless Frequency Range and Wireless Output Power:** **Transmitter:**

2403–2480MHz

16.3dBm

### **Receiver:**

2404–2476MHz

-1.33dBm

### **EU Manufacturer of Record:**

Horizon Hobby, LLC  
2904 Research Road  
Champaign, IL 61822 USA

### **EU Importer of Record:**

Horizon Hobby, GmbH  
Hanskampring 9  
22885 Barsbüttel Germany

### **WEEE NOTICE:**



This appliance is labeled in accordance with European Directive 2012/19/EU concerning waste of electrical and electronic equipment (WEEE). This label indicates that this product should not be disposed of with household waste. It should be deposited at an appropriate facility to enable recovery and recycling.



**E328**

## Replacement Parts / Ersatzteile / Pièces de rechange / Pezzi di ricambio

Part #	English	Deutsch	Français	Italiano
PRB281074	Canopy, Black	Verdeck, Schwarz	Verrière, Noire	Capottina, Nera
PRB281068	Canopy, White	Verdeck, Weiß	Verrière, Blanche	Capottina, Bianca
PRB281118	Pro Boat Water Resistant Receiver Box	Pro Boat Wasserdichte Empfänger-Box	Récepteur Pro Boat résistant à l'eau	Scatola ricevitore resistente all'acqua Pro Boat
PRB281124	Trim Tab Set	Trimklappen-Satz	Ensemble volet compensateur	Set correttori assetto
PRB281125	Turn Fin Set	Drehflossensatz	Ensemble dérive de rotation	Set pinne di virata
PRB281126	Rudder Set	Rudersatz	Ensemble gouvernail	Set timone
PRB281127	Hull, Black	Schiffskörper, Schwarz	Coque, Noire	Scafo, Nero
PRB281128	Hull, White	Schiffskörper, Weiß	Coque, Blanche	Scafo, Bianca
PRB282055	Propeller, 1.73 x 1.6: 3/16 Shaft	Propeller, 1,73 x 1,6: 3/16 Welle	Hélice, 1,73 x 1,6 : Arbre 3/16	Elica 1,73 x 1,6: Albero 3/16
PRB282056	Flex Shaft	Flexwelle	Arbre flexible	Albero flessibile
PRB282093	Propeller Strut	Propellerstange	Hauban de l'hélice	Supporto elica
PRB282094	Stuffing Tube	Füllrohr	Tube de remplissage	Tubo ingrassatore
PRB285002	Break Away Bolt	Abreißschraube	Boulon à rupture	Bullone frangibile
PRB286056	Motor Coupler: 5mm (Motor) 4.7mm (Flexshaft)	Motorkupplung: 5 mm (Motor) 4,7 mm (Flexwelle)	Coupleur du moteur : 5 mm (moteur) 4,7 mm (arbre flexible)	Accoppiamento motore: 5 mm (motore) 4,7mm (albero flessibile)
PRB286058	Miscellaneous Hardware	Diverse Hardware	Matériel divers	Hardware vario
PRB286084	Canopy Thumb Screw Set	Daumenschraubensatz für Kabinendach	Ensemble vis à oreilles de la verrière	Kit viti zigrinate capottina
PRB286095	Rudder Cover	Ruderabdeckung	Protection du gouvernail	Coperchio timone
PRB286096	Servo Mount Set	Servohalterungssatz	Ensemble support de servo	Set supporto servo
PRB286097	Motor Mount Set	Motorhalterung	Support moteur	Montante motore
PRB289008	Decal Set T1/T2 Sonicwake 36 V2	Decal-Satz T1/T2 Sonicwake 36 V2	Feuillet d'autocollants T1/T2 Sonicwake 36 V2	Set adesivi T1/T2 Sonicwake 36 V2
SPMS605	9KG Servo, WP, Metal, 23T	Spektrum S605 9KG WP-Metall-Servo 23T	Servo 9Kg à pignons métal, étanche, tête 23T	Servocomando 9kg, WP, ingranaggio in metallo, 23T
SPMSR315	SR315 DSMR 3CH Receiver	SR315 DSMR 3CH Empfänger	Récepteur 3 canaux SR315 DSMR	Ricevitore SR315 DSMR 3 canali
SPMSLT300	SLT3 3-Channel SLT Radio System with SR315 Dual Protocol	SLT3 3-Kanal-SLT-Funksystem mit SR316 Dual-Protokoll	Système radio SLT à 3 canaux SLT3 avec double protocole SR316	Radiocomando SLT-3 a 3 canali con SR316 a doppio protocollo
SPMXME1120	Firma 120A BL Smart Marine ESC 3-6S	Firma 120A BL Smart-Marine-Geschwindigkeitsregler 3-6S	Variateur ESC marin 120 A sans balais Smart Firma 3-6S	ESC Firma 120A BL Smart Marine 3-6S
SPMXMM3300	Firma 1900KV Brushless Marine Motor	Firma 1900KV bürstenloser Schiffsmotor	Moteur marin sans balais Firma 1900 KV	Motore marino Firma 1900 Kv Brushless



## Optional Parts / Diverse Teile / Pièces optionnelles / Pezzi opzionali

Part #	English	Deutsch	Français	Italiano
DYN2803	Nut Driver: 5.5mm	Dynamite Steckschlüssel:5.5mm	Clé à écrou 5,5mm	Chiave per dadi: 5,5mm
DYN2805	Nut Driver: 8mm	Dynamite Steckschlüssel:8mm	Clé à écrou 8mm	Chiave per dadi: 8mm
DYN2819	5 pc Metric Hex Driver Assortment	Dynamite metrischer Inbusschlüsselsatz 1,5-4 mm (5 Stk)	Assortiment de 5 clé hexagonales métriques	Set chiavi esagonali metrici (5 pz)
DYN4403	Passport GPS Speed Meter 2.0	GPS Tachometer 2.0	Indicateur de vitesse GPS 2.0 Passport	Tachimetro Passport GPS 2.0
DYN5500	Magnum Force 2 Motor Spray, 13oz	Magnum Force 2 Motorspray, 368 g	Vaporisateur pour moteur Magnum Force 2, 369 g (13 oz)	Spray motore Magnum Force 2, 385 ml
DYNE4200	Grease Gun with Marine Grease 5 oz	Dynamite Fettpresse m. Marinefett 141 g	Pistolet avec graisse marine 140g	Grasso marino con pistola 5 oz
DYNE4201	Marine Grease 5 oz	Dynamite Marinefett 141 g	Graisse marine 140g	Grasso marino 5 oz
DYNF1055	Infrared Temp Gun with Laser	Infrarotmesspistole mit Laser	Détecteur infrarouge de température avec laser	Pistola misuratrice temperatura a infrarossi con puntamento laser
DYNK0300	Hook and Loop Tape Set, Waterproof 75 x 25mm 4pcs	Dynamite Klettbandset 75 x 25mm (4 Stk)	Adhésif auto-agrippant 75 x 25mm (4pcs)	Set nastro a strappo, WP 75 x 25mm 4pz
DYNM0102	Clear Flexible Marine Tape (18M)	Dynamite transparentes Marineklebeband 18 m	Adhésif Marin transparent flexible (18M)	Nastro marino trasparente flessibile (18M)
DYNT0502	Start Up Tool Set: Pro Boat	Dynamite Startup Werkzeugset: Pro Boat	Pro Boat - Set d'outils de démarrage	Start Up Tool Set: Pro Boat
PRB282028	Propeller, CCW, 1.4 x 1.65: 3/16 Shaft	Propeller, CCW 1,4 x 1,65: 3/16 Welle	Hélice, CCW, 1,4 x 1,65 : Arbre 3/16	Elica, rotazione antioraria, 1,4 x 1,65: Albero 3/16
PRB282047	Propeller, 1.7 x 1.6: 3/16 Shaft	Propeller, 1,7 x 1,6: 3/16 Welle	Hélice, 1,7 x 1,6 : Arbre 3/16	Elica 1,7 x 1,6: Albero 3/16
SPMMR4000	MR4000 DSMR 4CH Marine Receiver	MR4000 DSMR 4 Kanal Bootempfänger	Récepteur marin MR4000 DSMR 4 canaux	Ricevitore marino MR4000 4 canali DSMR
SPMSS6170	S6170 M-T / M-S Digital WP Servo	S6170 M-T / M-S Digitaler WP Servo	Servo impermeabile digitale M-S / S6170 M-T	Servo numérique étanche S6170 M-T/M-S
SPMSS6250	S6250 U-T / H-S Digital HV WP Servo	S6250 U-T / H-S Digitaler HV WP Servo	Servo numérique étanche S6250 U-T / H-S HV	Servo impermeabile digitale HV H-S / S6250 U
SPMX53S100H5	11.1V 5000mAh 3S 100C Smart G2 Hardcase LiPo Battery: IC5	11,1 V 5000 mAh 3S 100C Smart G2 LiPo-Akku, Hartschale: IC5	Batterie Li-Po Smart 11,1 V 5000 mAh 3S 100C G2, boîtier rigide : IC5	Batteria 11,1 V 5000 mAh 3S 100C Smart G2 Hardcase LiPo: IC5
SPMX50003S50H5	11.1V 5000mAh 3S 50C Smart Hardcase LiPo Battery: IC5	11,1 V 5000 mAh 3S 50C Smart LiPo-Akku, Hartschale: IC5	Batterie Li-Po Smart 11,1 V 5000 mAh 3S 50C, boîtier rigide : IC5	Batteria 11,1 V 5000 mAh 3S 50C Smart Hardcase LiPo: IC5
DYN4403	Passport GPS Speed Meter 2.0	Passport GPS Tachometer 2.0	Indicateur de vitesse GPS 2.0 Passport	Tachimetro Passport GPS 2.0
SPMXPS6	Smart PowerStage Bundle 6S	Smart PowerStage- Paket 6S	Ensemble Smart Powerstage 6S	Smart Powerstage Bundle 6S
SPMXCA200	Avian Firma Smart ESC Programmer	Avian Firma Smart ESC Programmer	Programmeur ESC Smart Firma Avian	Programmer Smart ESC Avian Firma
SPMXSE1160M	Firma 160A Smart BL Marine ESC	Firma 160A Smart BL Marine ESC	Variateur ESC marin sans balais Firma 160 A Smart	ESC marino Firma 160A Smart BL

130241 Created: 06/2021

©2021 Horizon Hobby, LLC.

Pro Boat, the Pro Boat logo, Sonicwake, Dynamite, EC5, IC5, DSMR, Firma, and the Horizon Hobby logo are trademarks or registered trademarks of Horizon Hobby, LLC. The Spektrum trademark is used with permission of Bachmann Industries, Inc. US 9,930,567. US 10,419,970. US 10,849,013.  
Other patents pending.

**PRB08032V2**