

**BLADE®**

**UMX**

**F-27**

**FPV**

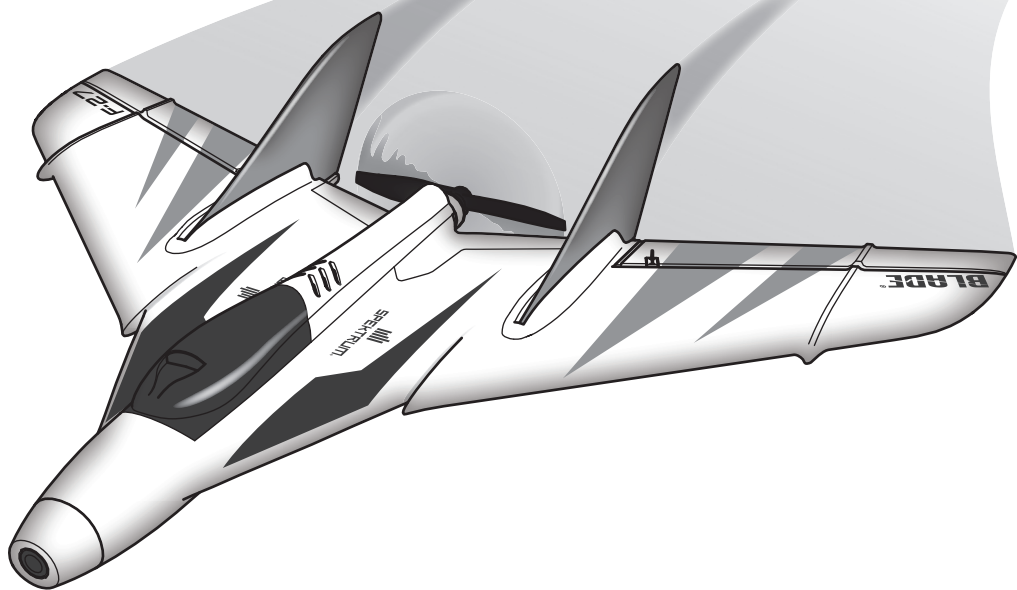

**Instruction Manual  
Bedienungsanleitung  
Manuel d'utilisation  
Manuale di Istruzioni**

**BNF**  
**BASIC**

## NOTICE

All instructions, warranties and other collateral documents are subject to change at the sole discretion of Horizon Hobby, LLC. For up-to-date product literature, visit [horizonhobby.com](http://horizonhobby.com) and click on the support tab for this product.

## Meaning of Special Language

The following terms are used throughout the product literature to indicate various levels of potential harm when operating this product:

**NOTICE:** Procedures, which if not properly followed, create a possibility of physical property damage AND a little or no possibility of injury.

**CAUTION:** Procedures, which if not properly followed, create the probability of physical property damage AND a possibility of serious injury.

**WARNING:** Procedures, which if not properly followed, create the probability of property damage, collateral damage, and serious injury OR create a high probability of superficial injury.



**WARNING:** Read the ENTIRE instruction manual to become familiar with the features of the product before operating. Failure to operate the product correctly can result in damage to the product, personal property and cause serious injury.

This is a sophisticated hobby product. It must be operated with caution and common sense and requires some basic mechanical ability. Failure to operate this Product in a safe and responsible manner could result in injury or damage to the product or other property. This product is not intended for use by children without direct adult supervision. Do not use with incompatible components or alter this product in any way outside of the instructions provided by Horizon Hobby, LLC. This manual contains instructions for safety, operation and maintenance. It is essential to read and follow all the instructions and warnings in the manual, prior to assembly, setup or use, in order to operate correctly and avoid damage or serious injury.

**Age Recommendation: Not for children under 14 years. This is not a toy.**

## Safety Precautions and Warnings

- Always keep a safe distance in all directions around your model to avoid collisions or injury. This model is controlled by a radio signal subject to interference from many sources outside your control. Interference can cause momentary loss of control.
- Always operate your model in open spaces away from full-size vehicles, traffic and people.
- Always carefully follow the directions and warnings for this and any optional support equipment (chargers, rechargeable battery packs, etc.).
- Always keep all chemicals, small parts and anything electrical out of the reach of children.
- Always avoid water exposure to all equipment not specifically designed and protected for this purpose. Moisture causes damage to electronics.
- Never place any portion of the model in your mouth as it could cause serious injury or even death.
- Never operate your model with low transmitter batteries.
- Always keep aircraft in sight and under control.
- Always move the throttle fully down at rotor strike.
- Always use fully charged batteries.
- Always keep transmitter powered on while aircraft is powered.
- Always remove batteries before disassembly.
- Always keep moving parts clean.
- Always keep parts dry.
- Always let parts cool after use before touching.
- Always remove batteries after use.
- Never operate aircraft with damaged wiring.
- Never touch moving parts.



**WARNING AGAINST COUNTERFEIT PRODUCTS:** If you ever need to replace a Spektrum component found in a Horizon Hobby product, always purchase from Horizon Hobby, LLC or a Horizon Hobby authorized dealer to ensure authentic high-quality Spektrum product. Horizon Hobby, LLC disclaims all support and warranty with regards, but not limited to, compatibility and performance of counterfeit products or products claiming compatibility with DSM or Spektrum technology.

**If you are operating this product in North America, you are required to have an Amateur Radio (HAM) license. Visit [www.arrl.org](http://www.arrl.org) for more information.**

## Table of Contents

First Flight Preparation.....	4	Using the Video Transmitter.....	10
Transmitter Setup.....	4	Changing the Propeller.....	11
Flying Checklist.....	4	Motor Service.....	11
Installing the Flight Battery.....	5	AS3X Troubleshooting Guide.....	11
Transmitter and Receiver Binding.....	5	Troubleshooting Guide.....	12
Control Horn Settings.....	6	Parts Explosion.....	13
Control Centering.....	6	Replacement Parts.....	13
Adjusting Center of Gravity (CG).....	6	Optional Parts.....	13
Flight Control Direction Tests.....	7	Limited Warranty.....	14
Flight Modes.....	8	Warranty and Service Contact Information.....	15
Flying Your Aircraft.....	8	FCC Information.....	15
In Flight Trimming.....	9	IC Information.....	15
Post Flight.....	9	Compliance Information for the European Union.....	15
Post-Flight Inspection.....	9		

## Specifications

<b>Wingspan</b>	17 in (432mm)
<b>Length</b>	12.7 in (323mm)
<b>Flying Weight</b>	2.68 oz (76 g)

### Box Contents:

- UMX F-27 FPV Wing

### Needed to Complete:

- Battery (2S, 280mAh LiPo)
- LiPo compatible charger
- DSM2®/DSMX® compatible, full range transmitter
- 5.8GHz FPV headset or ground station

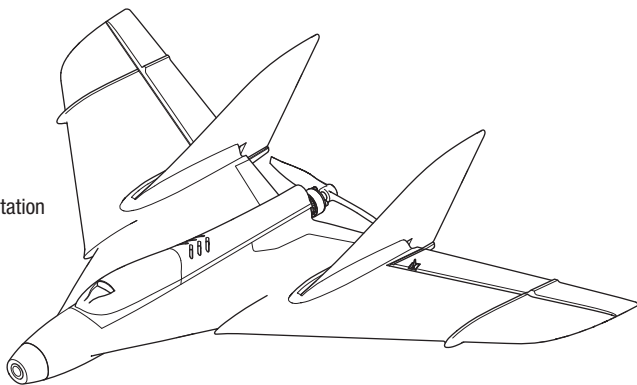

**NOTICE:** Consult local laws and ordinances before operating FPV (first person view) equipment. In some areas, FPV operation may be limited or prohibited. You are responsible for operating this product in a legal and responsible manner.

To receive product updates, special offers and more, register your product at [www.bladehelis.com](http://www.bladehelis.com).

## First Flight Preparation

- Remove and inspect contents
- Begin charging the flight battery
- Program your computer transmitter
- Install the flight battery in the aircraft (once it has been fully charged)
- Bind your transmitter
- Perform a control direction test
- Familiarize yourself with the controls
- Find a suitable area for flying

## Transmitter Setup

### Program Your Transmitter

1. Start with a clean model memory slot.
2. Set the model type to "Airplane".
3. Assign channel 5 (Gear) to a 3-position switch. Switch **B** is used in the table shown.
4. Set the Dual Rate/Expo settings to the values given in the table for **AS3X Mode only**.
5. Set the timer to 5 minutes.
6. Leave all other settings at the default values.

Switch **B** will now control the flight mode function.

Switch position 0 = **SAFE® Mode**

Switch position 1 = **SAFE® Mode**

Switch position 2 = **AS3X Mode**

If, after flying the aircraft, more or less exponential or dual rate values are desired, those may be adjusted up or down to suit your flying style.

## Flying Checklist

- Always turn the transmitter on first**
- Plug the flight battery into the lead from the ESC
- Allow the ESC to initialize and arm properly
- Fly the model
- Land the model
- Unplug the flight battery from the ESC
- Always turn the transmitter off last**

### DX6, DX7 (Gen 2), DX8 (Gen 2), DX9, DX18, DX20

SETUP LIST		FUNCTION LIST	
Model Type		Dual Rate/Expo (AS3X Mode only)	
Airplane		Switch	B
F-Mode Setup			DR Expo
Switch 1	Inhibit	Aileron	70% 30%
Switch 2	Inhibit	Elevator	70% 30%
Channel Assign		Timer	
Channel Input Config		Mode	Count Down
1 Throttle		Time	5:00
2 Aileron		Start	Throttle Out
3 Elevator		Over	25%
4 Rudder		One Time	Inhibit
5 Gear	Switch B		
6 Aux 1			
Frame Rate			
22ms			
DSMX			

## Installing the Flight Battery

1. Remove the canopy.
2. Insert the flight battery in the battery compartment.  
The recommended battery is a snug fit and should not require any other means of restraint. If the battery fits loosely in the battery compartment, apply hook and loop material to the battery and inside the compartment to hold the battery in place.
3. Connect the battery connector to the aircraft power lead, noting correct polarity.

**CAUTION:** Connecting the battery to the ESC with reversed polarity will cause damage to the ESC, the battery or both. Damage caused by incorrectly connecting the battery is not covered under warranty.

4. Keep the aircraft upright, level, out of the wind and immobile for approximately 10 seconds, until the receiver initializes. The ESC will emit a series of tones and the LED on the receiver will light.
5. Replace the center section cover.

If you have not previously bound the aircraft to your transmitter the LED on the receiver will rapidly flash red. Proceed to the Transmitter and Receiver Binding section. If the receiver does not fully initialize, re-bind the receiver to your transmitter as shown in the Transmitter and Receiver Binding section.

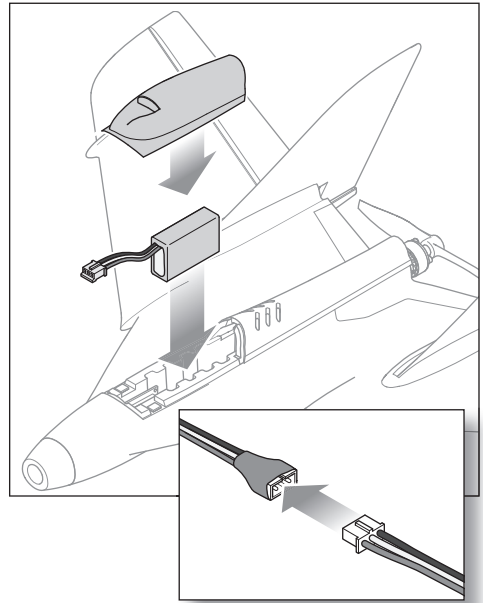

## Transmitter and Receiver Binding

Binding is the process of programming the receiver of the control unit to recognize the GUID (Globally Unique Identifier) code of a single specific transmitter. You need to 'bind' your chosen Spektrum™ DSM2®/DSMX® technology equipped aircraft transmitter to the receiver for proper operation.

If you encounter problems, obey binding instructions and refer to your transmitter troubleshooting guide for other instructions. If needed, contact the appropriate Horizon Product Support office for further assistance.

**CAUTION:** Always keep hands away from the propeller. When the aircraft is armed, the motor will turn the propeller in response to any throttle stick input.

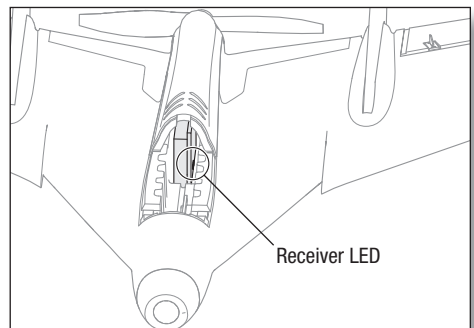

### Binding Procedure

1. Disconnect the flight battery.
2. Power off the transmitter.
3. Connect the flight battery in the aircraft. The aircraft will beep and the receiver LED will rapidly flash red indicating the receiver is in bind mode.
4. Make sure transmitter controls are neutral and the throttle is at the lowest setting with the throttle trim at or below the middle.
5. Put your transmitter into bind mode. Refer to your transmitter manual for binding instructions.
6. The receiver LED will glow solid, indicating that the receiver is bound to the transmitter. If the LED does not glow solid, refer to the Troubleshooting Guide section.

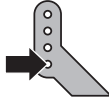

## Control Horn Settings

The table at the right shows the factory settings for the elevon control horns and servo arms. Do not make changes to the elevon linkages.

Control Horns	Servo
	

## Control Centering

**Before the first flights, or in the event of an accident, make sure control surfaces are centered when the transmitter controls and trims are neutral. The transmitter sub-trim must be set to zero.**

Adjust the linkages mechanically if the control surfaces are not centered. Use of the transmitter sub-trims may not correctly center the aircraft control surfaces due to the mechanical limits of linear servos.

Make the U-shape narrower to make the connector shorter. Make the U-shape wider to make the linkage longer.

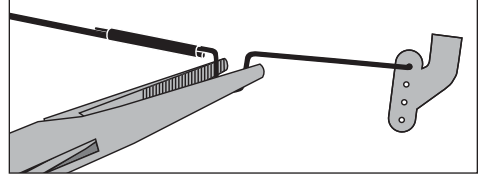

**NOTICE:** Ultra micro linear servos are unique in that they are calibrated to reach maximum travel at 100% travel adjust. Increasing the value above 100% will NOT result in more travel, but can cause the servo to lock and will result in a crash.

## Adjusting Center of Gravity (CG)

The recommended CG location is **67mm** (2.6 inches) forward from the firewall at the back of the fuselage. This CG location has been determined with the included 2S 280mAh 7.4V Li-Po battery installed approximately in the center of the battery cavity.

The battery cavity is oversized to allow for center of gravity adjustment. Start by placing the battery in the center of the cavity and adjust as necessary to achieve the proper center of gravity.

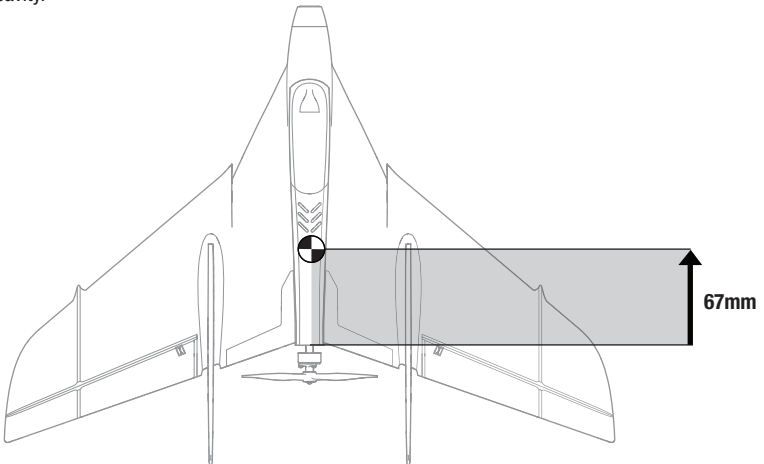

# Flight Control Direction Tests

## Transmitter input test

This test ensures that the flight control system is reacting properly to your transmitter inputs. Assemble the aircraft and bind your transmitter to the aircraft receiver prior to performing this test.







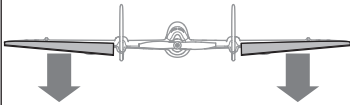

**CAUTION:** Keep all body parts, hair and loose clothing away from the propeller at all times, as these items could become entangled.

Set the transmitter flight mode switch to AS3X mode (position 2).

Hold the aircraft horizontal and view it from the rear. Once the flight control system is active, the control surfaces may move rapidly when moving the aircraft. This is normal.

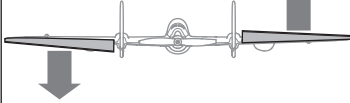
Move the aileron/elevator control as shown in the “Transmitter Input” column of the table. The control surfaces should react to your inputs by moving in the directions shown in the “Control Surface Reaction” column. If any of the control surfaces do not respond in the proper direction, ensure the corresponding transmitter channel is NOT reversed.

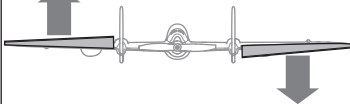
Transmitter Input	Control Surface Reaction (viewed from the rear)
 Elevator forward	
 Elevator back	
 Aileron right	
 Aileron left	

## Stabilization system test

This test ensures that the aircraft stabilization system is reacting properly to external inputs. Assemble the aircraft and bind your transmitter to the receiver before performing this test.







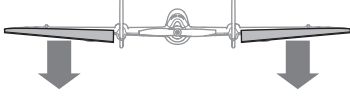

**CAUTION:** Keep all body parts, hair and loose clothing away from the propeller at all times, as these items could become entangled.

Set the transmitter flight mode switch to AS3X mode (position 2).

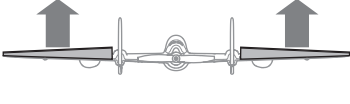
Hold the aircraft horizontal and view it from the rear. Once the flight control system is active, the control surfaces may move rapidly when moving the aircraft. This is normal.

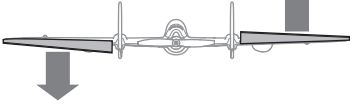
Move the aircraft as shown in the “Aircraft Movement” column of the table. The control surfaces should react to your inputs by moving in the directions shown in the “Control Surface Reaction” column. If any of the control surfaces do not respond in the proper direction, DO NOT fly the aircraft. Contact Horizon Hobby customer support.

Aircraft Movement	Control Surface Reaction (viewed from the rear)
 Pitch up	
 Pitch down	
 Roll left	
 Roll right	

## Flight Modes

The aircraft has two flight modes pre-programmed into the receiver:

### SAFE® Mode (switch position 0 or 1)

In SAFE® Mode the aircraft has bank and pitch limiting to help prevent the pilot from over-controlling. The aircraft dampens any outside forces to give a smooth flight performance, even in moderate wind and turbulence. This mode does not have self leveling. Use this mode to help get the feel of the aircraft before moving on to more advanced aerobatic flight.

- Receiver LED red
- Limited bank and pitch angle
- Self levelling when the controls are centered

### Acro Mode (switch position 2)

Experienced Mode has no bank or pitch limiting, giving an unlimited flight envelope. The aircraft dampens any outside forces to give a smooth flight performance, even in moderate wind and turbulence.

Acro mode is intended for experienced pilots who are comfortable flying the aircraft in any orientation.

- Receiver LED blue and red
- No bank angle limits
- No self levelling when the controls are centered
- Fully aerobatic capable

## Flying Your Aircraft

**Consult local laws and ordinances before choosing a flying location.**

### Range Check your Radio System

Before you fly, range check the radio system. Refer to your specific transmitter instruction manual for range test information.

### Just Before Flight

The recommended battery is the EFLB2802S30 280mAh LiPo. For best results, always use a fresh battery.

For your first flights with the recommended 280mAh battery pack, set your transmitter timer or a stopwatch to 5 minutes.

**NOTICE:** Never fly the aircraft without first setting and activating a timer.

After 5 minutes, land the aircraft. Adjust your timer for longer or shorter flights depending on your preference and battery usage.

### Stability and Acro Forward Flight

Fly the aircraft and trim it for level flight per the In Flight Trimming section.

The aircraft flies in a very similar manner to any other fixed-wing aircraft. It is capable of a wide range of aerobatic maneuvers, including loops and rolls.

### Hand Launching

1. Lower the throttle to the lowest setting. The aircraft will not arm unless the throttle is fully lowered.
2. Power on the model normally, allowing it to initialize completely.
3. Set the flight mode switch to SAFE® Mode.
4. Toss the aircraft into the wind and immediately increase the throttle after the aircraft has cleared your hand.

### Landing

To land, turn the aircraft into the wind and lower the throttle to decrease the forward speed. Fly the aircraft to approximately 6 inches (15cm) or less above the runway, using a small amount of throttle for the entire descent. Keep the throttle on until the aircraft is ready to touch down.

Just before touch down, keep the wings level and the airplane pointed into the wind. Gently lower the throttle while easing back on the elevator to bring the aircraft to touch down on the runway as slowly and gently as possible.

The average flight time using the recommended 280mAh flight battery is approximately 5 minutes.

After landing, disconnect and remove the Li-Po battery from the aircraft to prevent trickle discharge. Charge your Li-Po battery to about half capacity before storage. During storage, make sure the battery voltage does not fall below 3V per cell.

**NOTICE:** If a crash is imminent, fully lower the throttle immediately to stop the motors to reduce the possibility of damage to the airframe and electronic components.

**NOTICE:** Crash damage is not covered under warranty.

**NOTICE:** Never leave the aircraft in direct sunlight or in a hot, enclosed area such as a car. Doing so can damage the aircraft.

### Low Voltage Cutoff (LVC)

When a Li-Po battery is discharged below 3V per cell, it will not hold a charge. The aircraft's ESC protects the flight battery from over-discharge using Low Voltage Cutoff (LVC). Once the battery discharges to approximately 3.3V per cell, the LVC will reduce the power to the motor in order to leave adequate power to the receiver and servos to land the aircraft.

If the motors cut off, surge in power or slowly lose power, land immediately and replace or recharge the flight battery.

**NOTICE:** Repeated flying to LVC may damage the flight battery.

LVC does not prevent the battery from over-discharge during storage.

**Tip:** Monitor your aircraft battery's voltage before and after flying by using a Li-Po Cell Voltage Checker (EFLA111, sold separately).

### Repairs

Thanks to the Z-Foam™ material in this aircraft, most repairs to the foam can be made using virtually any adhesive (hot glue, regular CA, epoxy, etc). When parts are not repairable, refer to the parts list at the end of this manual for a listing of all replacement and optional parts for ordering by item number.

**NOTICE:** When using cyanoacrylate (CA) adhesive to join or repair the airframe, **DO NOT** allow the adhesive to contact or get close to the fpv camera lens. The vapors from the adhesive will permanently fog the camera lens.



## In Flight Trimming

Familiarize yourself with the Flying Your Aircraft section prior to trimming your aircraft. Trimming should be done in calm wind conditions and with a fully charged transmitter and flight battery. Trimming should only be necessary in AS3X mode, as the flight controller will compensate for minor trim issues in SAFE mode. It is important to make any trim adjustments mechanically in the control linkages and re-set the transmitter trims to center to keep any changes made from affecting SAFE mode.

1. Power on and takeoff normally.
2. Change the flight mode to AS3X and fly straight and level at approximately 3/4 throttle.
3. Trim the aircraft for level flight using the trim buttons on the transmitter.
4. When the aircraft maintains reasonable straight and level flight, land the aircraft.

5. Set the flight mode back to AS3X mode if it was changed for landing. Power cycle the aircraft. Do not activate the throttle. Take note of the neutral position of the control surfaces.
6. Adjust the control linkages mechanically, as shown in the "Control Centering" section, to compensate for the amount of trim entered.
7. Re-center the trims on the transmitter. The transmitter trims should always be centered for best flight performance.
8. Fly the aircraft again to check the changes made.
9. Repeat the trimming process until the aircraft will maintain reasonable straight and level flight without excessive control corrections.

When the initial trimming process is done, the aircraft should not require large amounts of trimming on subsequent flights. If large amounts of trim are needed to hold straight and level on later flights, land the aircraft and check the control surfaces for damage or binding.

## Post Flight

1. Disconnect the flight battery from the flight controller	5. Repair or replace all damaged parts.
2. Power OFF the transmitter.	6. Store the flight battery apart from the aircraft and monitor the battery charge.
3. Remove the flight battery from the aircraft.	7. Make note of the flight conditions and flight plan results, planning for future flights.
4. Recharge the flight battery.	

## Post-Flight Inspection



**WARNING:** Remove the propellers from the motors prior to performing any troubleshooting or maintenance. Failure to do so may cause serious injury if the motors start unexpectedly.

<b>Cleaning</b>	Make sure the battery is not connected before cleaning. Remove dust and debris with a soft brush or a dry lint free cloth.
<b>Airframe</b>	Check the airframe for any cracks or other damage. Minor repairs to the foam can be made using CA or epoxy. Badly damaged parts should be replaced.
<b>Control Linkages</b>	Make sure the control horns are secure. Make sure the control rods are secure in the control horns.
<b>Wiring</b>	Make sure wiring does not contact moving parts. Replace damaged wiring and loose connectors.
<b>Fasteners</b>	Make sure there are no loose screws, other fasteners or connectors. Do not over tighten metal screws in plastic parts. Tighten screw so parts are mated together, then turn screw only 1/8th of a turn more.
<b>Propeller</b>	Make sure there is no damage to the propeller blades. Damage includes cracks, burrs, chips or scratches. Replace damaged parts before the next flight.
<b>Receiver</b>	Make sure the electronics are securely attached to the frame. The aircraft will crash if the receiver separates from the frame.

## Using the Video Transmitter

Consult local laws and ordinances before operating FPV equipment. In some areas, FPV operation may be limited or prohibited. You are responsible for operating this product in a legal and responsible manner.

We recommend becoming familiar with the flight characteristics of the aircraft using line-of-sight prior to attempting to fly through the FPV system. After you are comfortable flying the aircraft, follow the directions below to operate the video transmitter in conjunction with your video monitor or goggles to explore flying via FPV.

See the Available Frequency table to find the desired video channel and band. The video transmitter channel and band are changed using the button on the video transmitter, as shown. There are 6 LEDs on the video transmitter board. The red LED is the channel indicator. The next 5 blue LEDs are the band indicators.

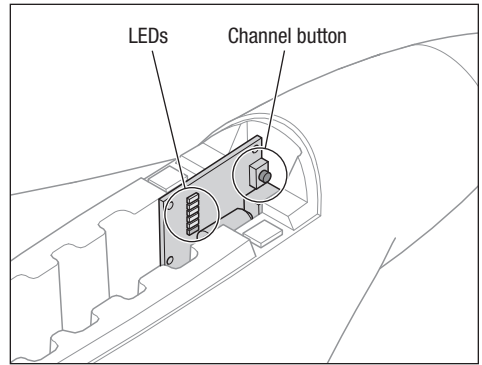

### Channel Selection:

1. Channel 1 is indicated by the red LED glowing solid.
2. Press the button to cycle through the channels (1-8). The red LED will flash once as you cycle through each channel. Press the button once for each channel until the desired channel is reached. If unsure of the current transmitter channel, press the button to cycle the channels until you reach channel 1, indicated by a solid red LED, then cycle to the channel desired.

### Band Selection:

1. Press and hold the button to change the video transmitter band.
2. Each time the button is pressed and held, the blue band LED will indicate a change to the next available band. The blue LEDs indicate FS/IRC band, band E (North America only), band A, race band and band B, as shown in the illustration.

### Video Transmitter LEDs

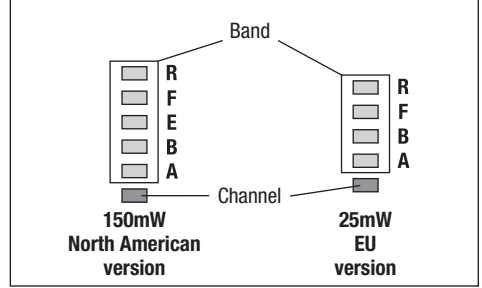

### Available Frequencies, North America (mHz)

Band	CH 1	CH 2	CH 3	CH 4	CH 5	CH 6	CH 7	CH 8
Band A	5865	5845	5825	5805	5785	5765	5745	5725
Band B	5733	5752	5771	5790	5809	5828	5847	5866
Band E	5705	5685	5665	5665	5885	5905	5905	5905
FS/IRC	5740	5760	5780	5800	5820	5840	5860	5880
RaceBand	5658	5695	5732	5769	5806	5843	5880	5917

### Available Frequencies, European Union (mHz)

Band	CH 1	CH 2	CH 3	CH 4	CH 5	CH 6	CH 7	CH 8
Band A	5865	5845	5825	5805	5785	5765	5745	5745
Band B	5733	5752	5771	5790	5809	5828	5847	5866
FS/IRC	5740	5760	5780	5800	5820	5840	5860	5860
RaceBand	5732	5732	5732	5769	5806	5843	5843	5843

## Changing the Propeller



**CAUTION:** Always disconnect the flight battery before performing propeller service.

1. Remove the 5mm washer head propeller screw.
2. Pull the propeller from the propeller adapter.
3. Place the new propeller on the propeller adapter with the raised numbers on the prop facing toward the motor and the front of the aircraft.
4. Install the propeller screw. DO NOT overtighten the screw as damage to the propeller and propeller adapter may result.

Never use thread locking compound on the propeller screw or the propeller adapter.

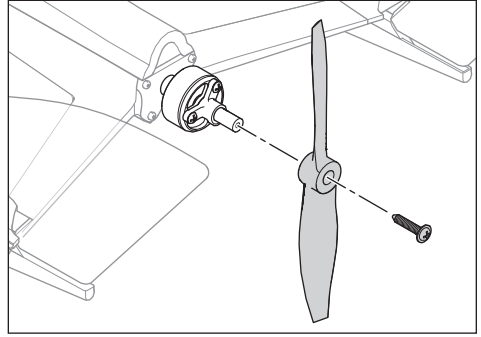

## Motor Service



**CAUTION:** Always disconnect the flight battery before performing motor service.

### Motor Removal

1. Disconnect and remove the flight battery from the aircraft.
2. Remove the propeller.
3. Remove the propeller adapter from the motor.
4. Using a sharp knife, carefully cut the tape along the base of the rear top hatch and remove the hatch.
5. Unplug the motor lead from the ESC and peel back tape securing the motor lead.
6. Remove four 5mm screws from the motor mount and pull the motor and mount away from the airframe.
7. Remove the 8mm screw from the motor mount and slide the motor out of the mount.

Assemble in reverse order.

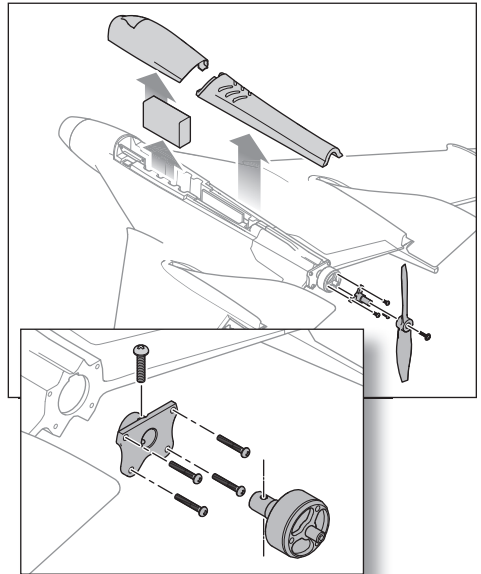

## AS3X Troubleshooting Guide

Problem	Possible Cause	Solution
Oscillation in flight	Damaged propeller	Replace propeller
	Propeller out of balance	Balance the propeller
	Motor vibration	Replace parts or correctly align all parts and tighten fasteners as needed
	Loose receiver	Align and secure receiver in fuselage
	Loose aircraft controls	Tighten or otherwise secure parts (servo, linkage, horn and control surface)
	Worn parts	Replace worn parts (especially propeller or servo)
Inconsistent flight performance	Irregular servo movement	Replace servo
	Trim is not at neutral	If you adjust trim more than 8 clicks, adjust the linkage to remove trim
	Sub-trim is not at neutral	No sub-trim is allowed. Adjust the servo linkage
	Aircraft was not kept immobile for 5 seconds after battery connection	With the throttle stick in lowest position. Disconnect battery, then reconnect battery and keep the aircraft still for 5 seconds

# Troubleshooting Guide

Problem	Possible Cause	Solution
Aircraft will not respond to throttle but responds to other controls	Throttle stick and/or throttle trim is too high	Reset controls with throttle stick and throttle trim at lowest setting
	Throttle channel is reversed	Reverse throttle channel on transmitter
	Motor is unplugged from receiver	Open fuselage and ensure the plug for the motor is properly installed
Extra propeller noise or extra vibration	Damaged propeller, prop shaft or motor	Replace damaged parts
	Screw on prop shaft is too loose	Tighten the prop shaft screw 1/2 turn
Reduced flight time or aircraft underpowered	Flight battery charge is low	Completely recharge flight battery
	Propeller is installed backwards	Install propeller with numbers facing forward
	Flight battery is damaged	Replace flight battery and follow flight battery instructions
	Flight conditions may be too cold	Make sure battery is warm before use
	Battery capacity is too low for flight conditions	Replace battery or use a larger capacity battery
LED on receiver flashes rapidly and aircraft will not bind to transmitter (during binding)	Transmitter is too near aircraft during binding process	Power off transmitter, move transmitter a larger distance from aircraft, disconnect and reconnect flight battery to aircraft and follow binding instructions
	Bind switch or button was not held while transmitter was powered on	Power off transmitter and repeat bind process
LED on receiver flashes rapidly and aircraft will not respond to transmitter (after binding)	Less than a 5-second wait between first powering on transmitter and connecting flight battery to aircraft	Leaving transmitter on, disconnect and reconnect flight battery to aircraft
	Aircraft is bound to a different model memory (ModelMatch™ radios only)	Select correct model memory on transmitter and disconnect and reconnect flight battery to aircraft
	Flight battery/transmitter battery charge is low	Replace/recharge batteries
Control surface does not move	Control surface, control horn, linkage or servo damage	Replace or repair damaged parts and adjust controls
	Wire damaged or connections loose	Do a check of wires and connections; connect or replace as needed
	Flight battery charge is low	Fully recharge flight battery
	Control linkage does not move freely	Make sure control linkage moves freely
Controls reversed	Transmitter settings reversed	Do the Control Direction Test and adjust controls on transmitter appropriately
Motor loses power	Damage to motor or power components	Do a check of motor and power components for damage (replace as needed)
Motor power quickly decreases and increases then motor loses power	Battery power is down to the point of receiver/ESC Low Voltage Cutoff (LVC)	Recharge flight battery or replace battery that is no longer performing
Servo locks or freezes at full travel	Travel adjust value is set above 100% overdriving the servo	Set Travel adjust to 100% and/or set sub trims to zero and adjust linkages mechanically.
Horizontal lines in the headset display	Interference on chosen channel	Change the video transmitter and receiver channel
Static or "snow" in the FPV feed	The aircraft has reached the range limit for the video transmitter and receiver	Fly the aircraft back to within video range
	There is an obstruction between the aircraft and the video receiver	Do not fly behind objects such as buildings or trees

## Parts Explosion

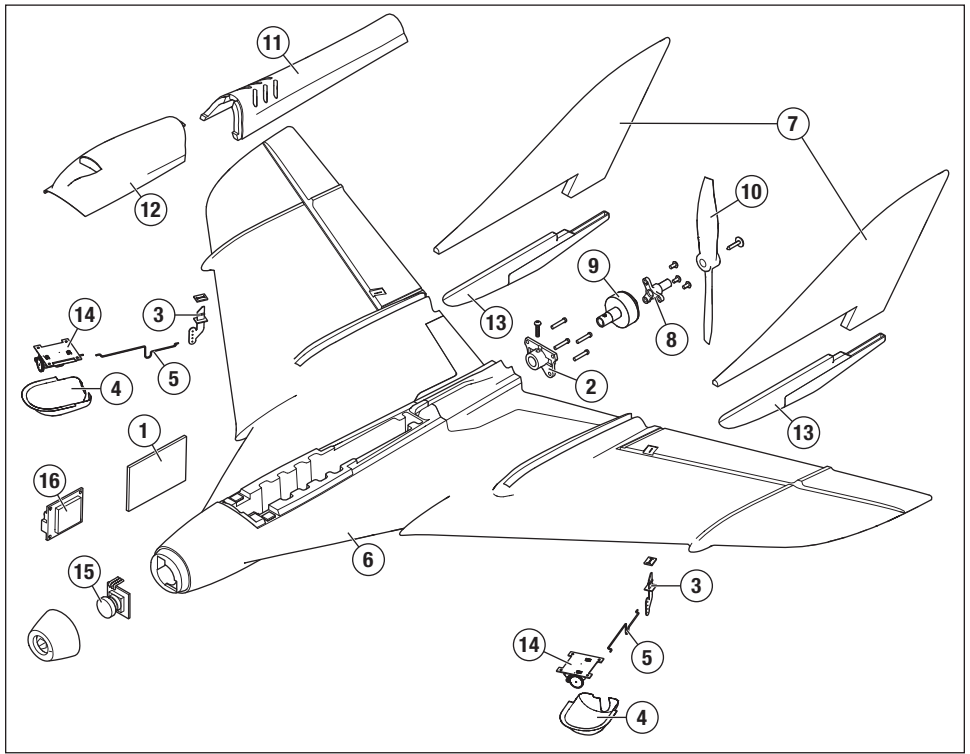

## Replacement Parts

Part #	Description
1	BLH03201 Flight Control: UM F-27 FPV
2	BLH03202 Motor Mount: UM F-27 FPV
3	BLH03203 Control Horn Set: UM F-27 FPV
4	BLH03204 Servo Cover Set: UM F-27 FPV
5	BLH03205 Pushrod Set: UM F-27 FPV
6	BLH03206 Wing/Fuse: UM F-27 FPV
7	BLH03207 Fin Set: UM F-27 FPV
8	EFLU4067 Prop Adaptor
9	EFLUM180BLB BL180 BL Outrunner Motor, 3000 Kv
10	EFLUP037503 3.75x3 Prop
11	PKZU2227 Rear Hatch
12	PKZU2228 Canopy
13	PKZU2229 Bottom Fin Set
14	SPM6832 Repl Servo Mechanics: UMLongThrow
15	SPMVCM01 FPV Camera
16	SPMVTM025 25mW VTX: European Union
16	SPMVTM150 150mW VTX: North America

## Optional Parts

Part #	Description
EFLB2802S30	280mAh 2S 7.4V 30C Li-Po
FSV1063	Dominator V3 Modular WVGA Headset
DUB916	Electric Flyer Hinge Tape

## Limited Warranty

### What this Warranty Covers

Horizon Hobby, LLC, (Horizon) warrants to the original purchaser that the product purchased (the "Product") will be free from defects in materials and workmanship at the date of purchase.

### What is Not Covered

This warranty is not transferable and does not cover (i) cosmetic damage, (ii) damage due to acts of God, accident, misuse, abuse, negligence, commercial use, or due to improper use, installation, operation or maintenance, (iii) modification of or to any part of the Product, (iv) attempted service by anyone other than a Horizon Hobby authorized service center, (v) Product not purchased from an authorized Horizon dealer, (vi) Product not compliant with applicable technical regulations, or (vii) use that violates any applicable laws, rules, or regulations.

OTHER THAN THE EXPRESS WARRANTY ABOVE, HORIZON MAKES NO OTHER WARRANTY OR REPRESENTATION, AND HEREBY DISCLAIMS ANY AND ALL IMPLIED WARRANTIES, INCLUDING, WITHOUT LIMITATION, THE IMPLIED WARRANTIES OF NON-INFRINGEMENT, MERCHANTABILITY AND FITNESS FOR A PARTICULAR PURPOSE. THE PURCHASER ACKNOWLEDGES THAT THEY ALONE HAVE DETERMINED THAT THE PRODUCT WILL SUITABLY MEET THE REQUIREMENTS OF THE PURCHASER'S INTENDED USE.

### Purchaser's Remedy

Horizon's sole obligation and purchaser's sole and exclusive remedy shall be that Horizon will, at its option, either (i) service, or (ii) replace, any Product determined by Horizon to be defective. Horizon reserves the right to inspect any and all Product(s) involved in a warranty claim. Service or replacement decisions are at the sole discretion of Horizon. Proof of purchase is required for all warranty claims. SERVICE OR REPLACEMENT AS PROVIDED UNDER THIS WARRANTY IS THE PURCHASER'S SOLE AND EXCLUSIVE REMEDY.

### Limitation of Liability

HORIZON SHALL NOT BE LIABLE FOR SPECIAL, INDIRECT, INCIDENTAL OR CONSEQUENTIAL DAMAGES, LOSS OF PROFITS OR PRODUCTION OR COMMERCIAL LOSS IN ANY WAY, REGARDLESS OF WHETHER SUCH CLAIM IS BASED IN CONTRACT, WARRANTY, TORT, NEGLIGENCE, STRICT LIABILITY OR ANY OTHER THEORY OF LIABILITY, EVEN IF HORIZON HAS BEEN ADVISED OF THE POSSIBILITY OF SUCH DAMAGES. Further, in no event shall the liability of Horizon exceed the individual price of the Product on which liability is asserted. As Horizon has no control over use, setup, final assembly, modification or misuse, no liability shall be assumed nor accepted for any resulting damage or injury. By the act of use, setup or assembly, the user accepts all resulting liability. If you as the purchaser or user are not prepared to accept the liability associated with the use of the Product, purchaser is advised to return the Product immediately in new and unused condition to the place of purchase.

### Law

These terms are governed by Illinois law (without regard to conflict of law principals). This warranty gives you specific legal rights, and you may also have other rights which vary from state to state. Horizon reserves the right to change or modify this warranty at any time without notice.

### WARRANTY SERVICES

#### Questions, Assistance, and Services

Your local hobby store and/or place of purchase cannot provide warranty support or service. Once assembly, setup or use of the Product has been started, you must contact your local distributor or Horizon directly. This will enable Horizon to better answer your

questions and service you in the event that you may need any assistance. For questions or assistance, please visit our website at [www.horizonhobby.com](http://www.horizonhobby.com), submit a Product Support Inquiry, or call the toll free telephone number referenced in the Warranty and Service Contact Information section to speak with a Product Support representative.

### Inspection or Services

If this Product needs to be inspected or serviced and is compliant in the country you live and use the Product in, please use the Horizon Online Service Request submission process found on our website or call Horizon to obtain a Return Merchandise Authorization (RMA) number. Pack the Product securely using a shipping carton. Please note that original boxes may be included, but are not designed to withstand the rigors of shipping without additional protection. Ship via a carrier that provides tracking and insurance for lost or damaged parcels, as Horizon is not responsible for merchandise until it arrives and is accepted at our facility. An Online Service Request is available at [http://www.horizonhobby.com/content/service-center\\_render-service-center](http://www.horizonhobby.com/content/service-center_render-service-center). If you do not have internet access, please contact Horizon Product Support to obtain a RMA number along with instructions for submitting your product for service. When calling Horizon, you will be asked to provide your complete name, street address, email address and phone number where you can be reached during business hours. When sending product into Horizon, please include your RMA number, a list of the included items, and a brief summary of the problem. A copy of your original sales receipt must be included for warranty consideration. Be sure your name, address, and RMA number are clearly written on the outside of the shipping carton.

**NOTICE: Do not ship LiPo batteries to Horizon. If you have any issue with a LiPo battery, please contact the appropriate Horizon Product Support office.**

### Warranty Requirements

**For Warranty consideration, you must include your original sales receipt verifying the proof-of-purchase date.**

Provided warranty conditions have been met, your Product will be serviced or replaced free of charge. Service or replacement decisions are at the sole discretion of Horizon.

### Non-Warranty Service

Should your service not be covered by warranty, service will be completed and payment will be required without notification or estimate of the expense unless the expense exceeds 50% of the retail purchase cost. By submitting the item for service you are agreeing to payment of the service without notification. Service estimates are available upon request. You must include this request with your item submitted for service. Non-warranty service estimates will be billed a minimum of ½ hour of labor. In addition you will be billed for return freight. Horizon accepts money orders and cashier's checks, as well as Visa, MasterCard, American Express, and Discover cards. By submitting any item to Horizon for service, you are agreeing to Horizon's Terms and Conditions found on our website [http://www.horizonhobby.com/content/service-center\\_render-service-center](http://www.horizonhobby.com/content/service-center_render-service-center).

**ATTENTION: Horizon service is limited to Product compliant in the country of use and ownership. If received, a non-compliant Product will not be serviced. Further, the sender will be responsible for arranging return shipment of the un-serviced Product, through a carrier of the sender's choice and at the sender's expense. Horizon will hold non-compliant Product for a period of 60 days from notification, after which it will be discarded. 10/15**

# Warranty and Service Contact Information

Country of Purchase	Horizon Hobby	Contact Information	Address
United States of America	Horizon Service Center (Repairs and Repair Requests)	servicecenter.horizonhobby.com/ RequestForm/	4105 Fieldstone Rd Champaign, Illinois, 61822 USA
	Horizon Product Support (Product Technical Assistance)	productsupport@horizonhobby.com 877-504-0233	
	Sales	websales@horizonhobby.com 800-338-4639	
European Union	Horizon Technischer Service	service@horizonhobby.de	Hanskampring 9 D 22885 Barsbüttel, Germany
	Sales: Horizon Hobby GmbH	+49 (0) 4121 2655 100	

## FCC Information

### FCC ID: BRWBLH03201

This equipment has been tested and found to comply with the limits for Part 15 of the FCC rules. These limits are designed to provide reasonable protection against harmful interference in a residential installation. This equipment generates uses and can radiate radio frequency energy and, if not installed and used in accordance with the instructions, may cause harmful interference to radio communications.

However, there is no guarantee that interference will not occur in a particular installation. If this equipment does cause harmful interference to radio or television reception,

which can be determined by turning the equipment off and on, the user is encouraged to try to correct the interference by one or more of the following measures:

- Reorient or relocate the receiving antenna.
- Increase the separation between the equipment and receiver.
- Connect the equipment to an outlet on a circuit different from that to which the receiver is connected.

This device complies with part 15 of the FCC rules. Operation is subject to the following two conditions: (1) This device may not cause harmful interference, and (2) this device must accept any interference received, including interference that may cause undesired operation.

**NOTICE:** Modifications to this product will void the user's authority to operate this equipment.

## IC Information

### IC: 6157A-BLH03201

This device complies with Industry Canada licence-exempt RSS standard(s). Operation is subject to the following two conditions: (1) this device may not cause interference, and

(2) this device must accept any interference, including interference that may cause undesired operation of the device."

## Compliance Information for the European Union



### EU Compliance Statement:

Horizon Hobby, LLC hereby declares that this product is in compliance with the essential requirements and other relevant provisions of the RED Directive.

A copy of the EU Declaration of Conformity is available online at: <http://www.horizonhobby.com/content/support-render-compliance>.



### Instructions for disposal of WEEE by users in the European Union

This product must not be disposed of with other waste. Instead, it is the user's responsibility to dispose of their waste equipment by handing it over to a designated collections point for the recycling of waste electrical and electronic equipment. The separate collection and recycling of your waste equipment at the time of disposal will help to conserve natural resources and make sure that it is recycled in a manner that protects human health and the environment. For more information about where you can drop off your waste equipment for recycling, please contact your local city office, your household waste disposal service or where you purchased the product.



© 2017 Horizon Hobby, LLC.

Blade, UMX, Celectra, DSM, DSM2, DSMX, AS3X, ModelMatch, Bind-N-Fly, BNF, the BNF logo, are trademarks or registered trademarks of Horizon Hobby, LLC. The Spektrum trademark is used with permission of Bachmann Industries, Inc. All other trademarks, service marks and logos are property of their respective owners.  
US D578,146. PRC ZL 200720069025.2. US 7,898,130. 2007001249. US 8,672,726. US 9,056,667.

Created 5/17      55409      BLH03250