

MSB1

1/10 2WD Electric Buggy

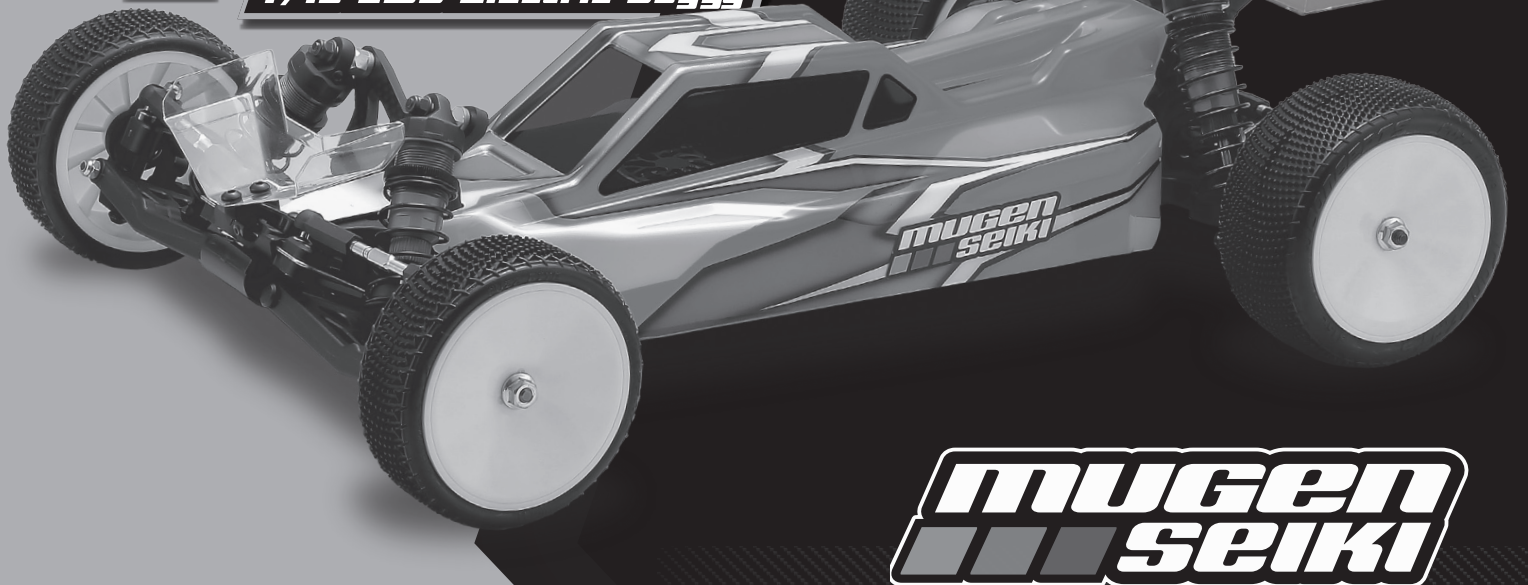

MUGEN SEIKI

● Items required for operation

- 2ch radio set for RC car (Transmitter, Receiver, Servo)
- Batteries for transmitter
- Motor
- ESC (Electric Speed Controller)
- Batteries for RC car
- Charger
- Body paint tools
- Tires / Wheels / Inner Foam

●キット以外に必要なもの

- RCカー用プロポ (送信機、受信機、サーボ)
- 送信機用バッテリー
- モーター
- スピードコントローラー
- 車体用バッテリー
- 充電器
- ボディ塗装用の塗料
- タイヤホイール/インナーフォーム

● Tools required

- Hexagon Wrenches (1.5mm/2mm/2.5mm)
- Box Wrench (5.5mm/7mm)
- Needle Nose Pliers
- Wire Cutters
- Sharp Hobby Knife
- Scissors
- Vernier Calipers
- Solder / Soldering Iron
- Screw Lock Liquid
- Instant Glue (High-intensity)

●キット製作に便利な工具類

- 六角レンチ (1.5mm/2mm/2.5mm)
- ボックスレンチ (5.5mm/7mm)
- ラジオペンチ
- ニッパー
- カッターナイフ
- ハサミ
- ノギス
- ハンダ&ハンダごて
- ネジロック剤
- 瞬間接着剤 (高強度)

● Neutral setting of transmitter

* Before setting, read the instructions attached to the transmitter and ESC.

1. Turn on the transmitter.
2. Set trims of transmitter to center.
3. Set throttle side of transmitter according to the instruction manual of ESC.
4. Turn on the ESC according to the instruction manual and set the default.
5. Check if the servos move properly in accordance with the control from transmitter.
6. Turn off the ESC.
7. Turn off the transmitter.

●プロポのニュートラル設定

* 使用するプロポ、スピードコントローラーに付属する取扱説明書をよく読み、事前に使用方法を理解しておいてください。

1. 送信機のスイッチをONにします。
2. 送信機のトリムをセンターに合わせます。
3. スピードコントローラーの説明書に従って、送信機のスロットル側の設定を行います。
4. 説明書に従って、スピードコントローラーのスイッチをONにし、初期設定を行います。
5. 送信機のハンドル/スティックを動かしてサーボが正常に動くか確認します。
6. スピードコントローラーのスイッチをOFFにします。
7. 送信機のスイッチをOFFにします。

Screw Chart These are the actual sizes of the screws included in the kit. 使用ビス類一覧

| | | | |
|-----------|---------|----------------|-----------------|
| SiG2x4 | SJG2x4 | SK3x3 | A2601 (3x6x2.5) |
| SiG2.5x 6 | SJG3x6 | SK3x5 | C0602 (5x8x2.5) |
| SiG2.5x10 | SJG3x8 | SK3x8 | E0602 (5x10x4) |
| SiG3x6 | SJG3x10 | SK3x10 | B2905 (5x13x4) |
| SiG3x8 | SJG3x12 | SK3x18 | B2907 (10x15x4) |
| SiG3x10 | SJG3x14 | OW2.6x6x0.5 | |
| SiG3x12 | SJG3x16 | OW3x7x0.5 | |
| SiG3x14 | SJG3x18 | OW3.55x7.5x0.2 | |
| SiG3x16 | SG2x8 | SN3 | |
| SiG3x18 | | SNF3 | |
| SiG3x20 | | SNF4 | |
| SiG3x22 | | | |

Before you start to assemble the kit, please read the instruction manual to the end.
組立てに入る前に説明書を最後までよく見てから作業を始めて下さい。



Apply Super Joint Grease.

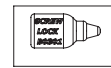

OPTION
Apply B0301 Lockfirm Liquid.

Step 1-1 / Bag A1,A2

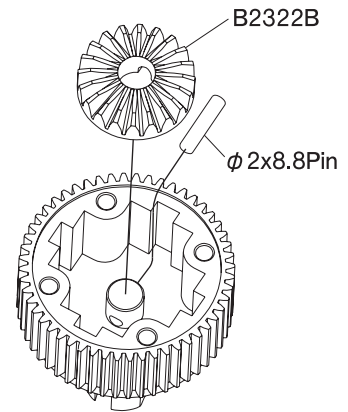
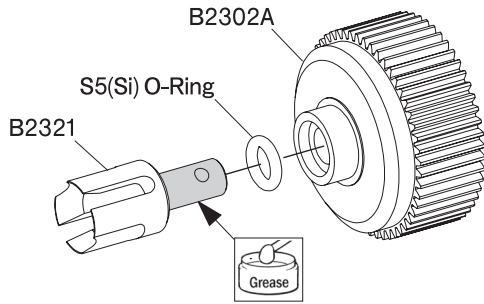

*Carpet

2gear

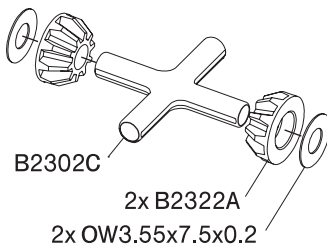

4gear

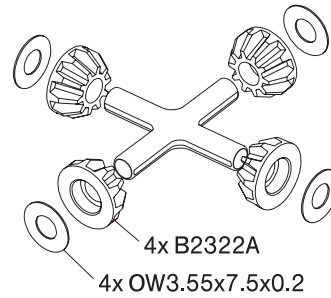

*Dirt

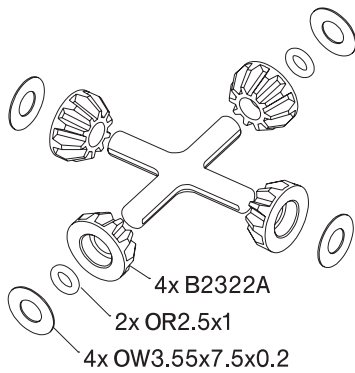

By inserting OR2.5x1 O-Ring, the feeling of contact with the road surface increases.

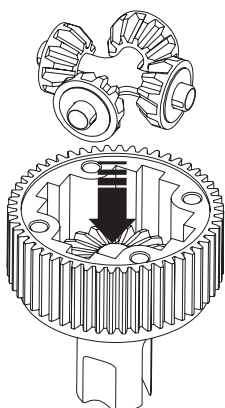

Fill the case with diff oil up to the point where cross pin.
Or make it 20.4g with diff oil.
19.0g for 2 gear.

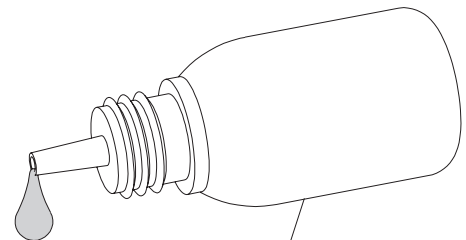

Diff Oil
4Gear : #4,000

2Gear : #7,000
(Not included)

Step 1-2 / Bag A1

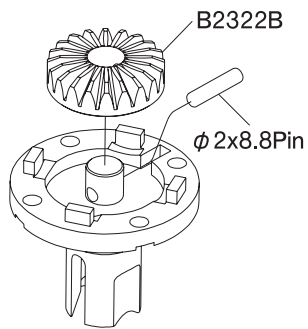
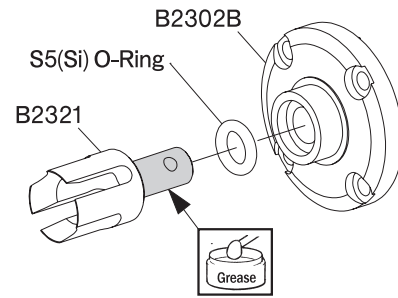
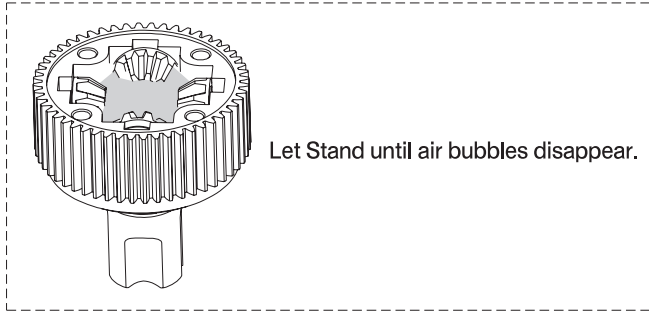

Step 1-3 / Bag A1

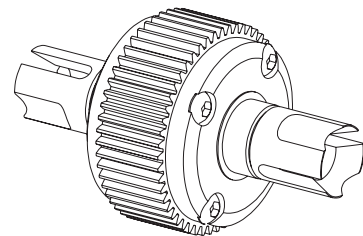
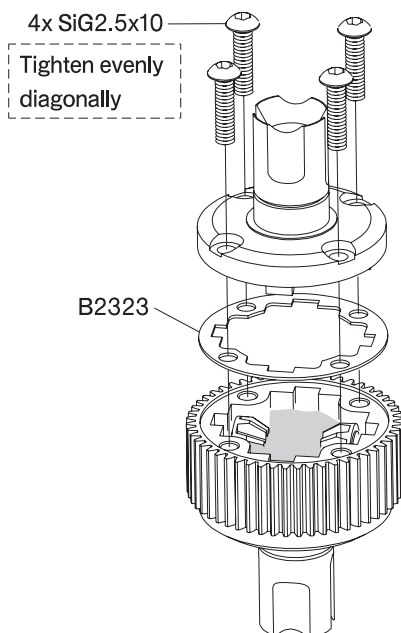

Step 2-1 / Bag A1

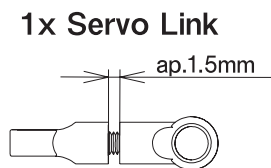
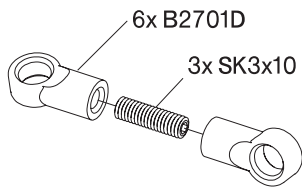
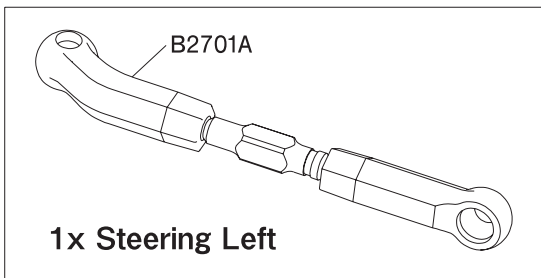
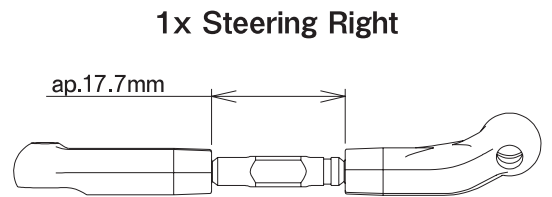
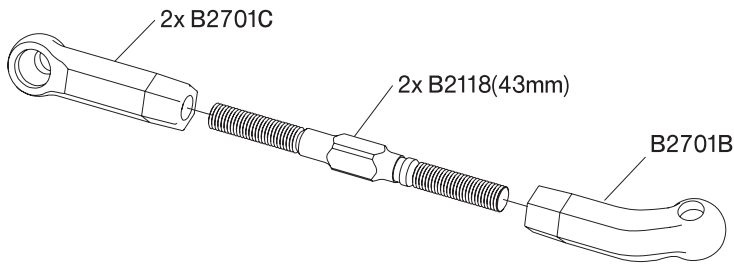
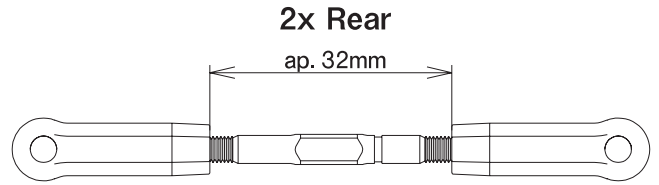
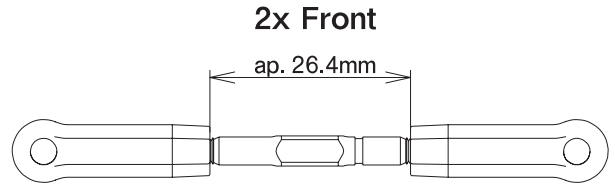
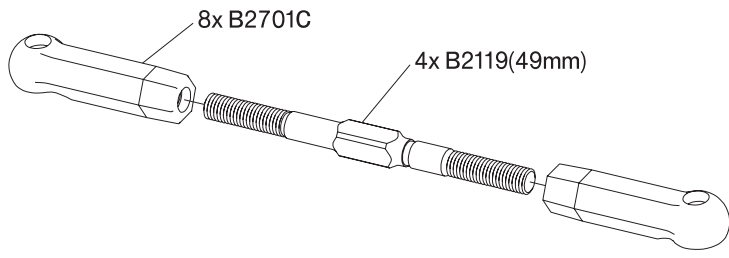

Rear Anti-roll Bar Link

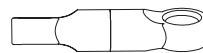

1x Left



1x Right

Step 3-1 / Bag B1

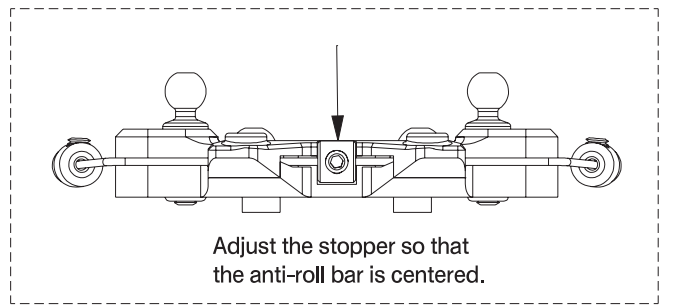
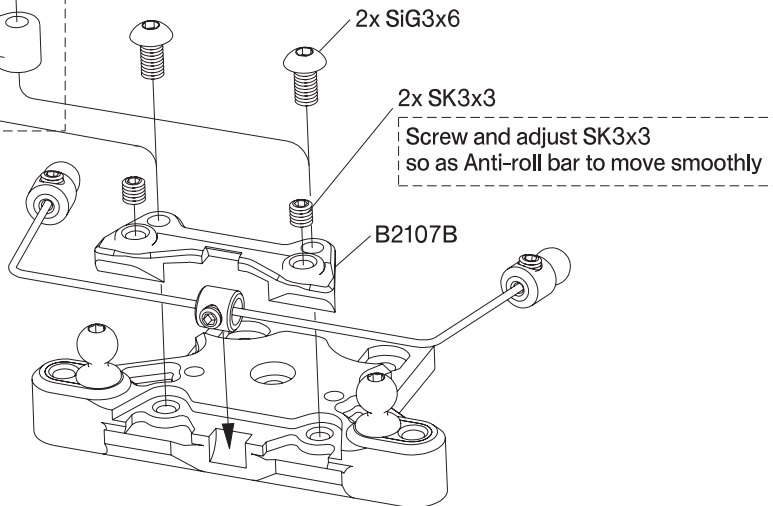
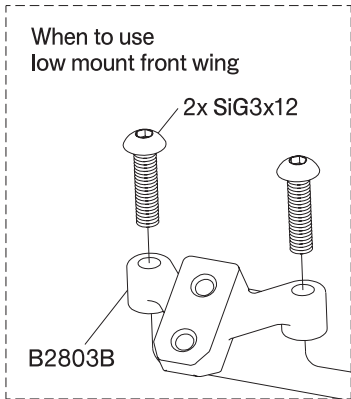
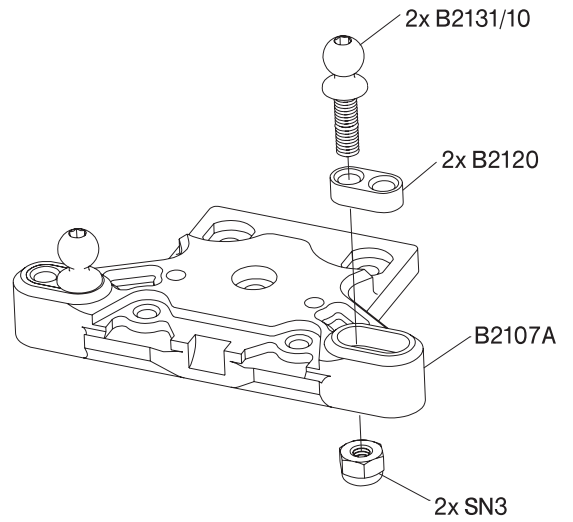
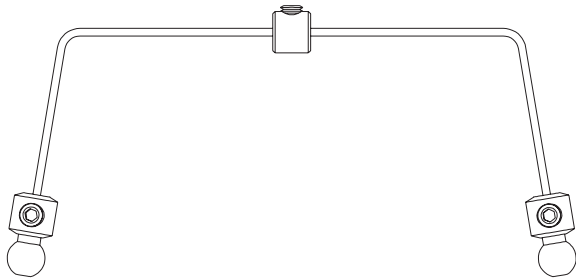
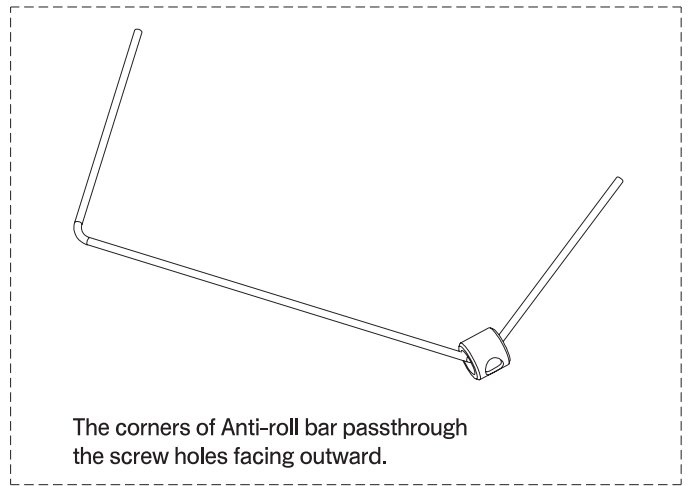
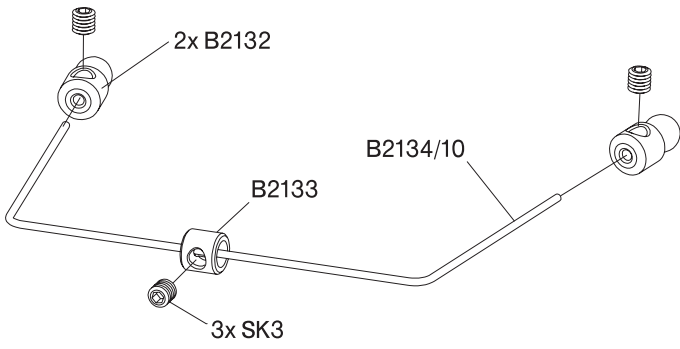

Step 3-2 / Bag B1, J1

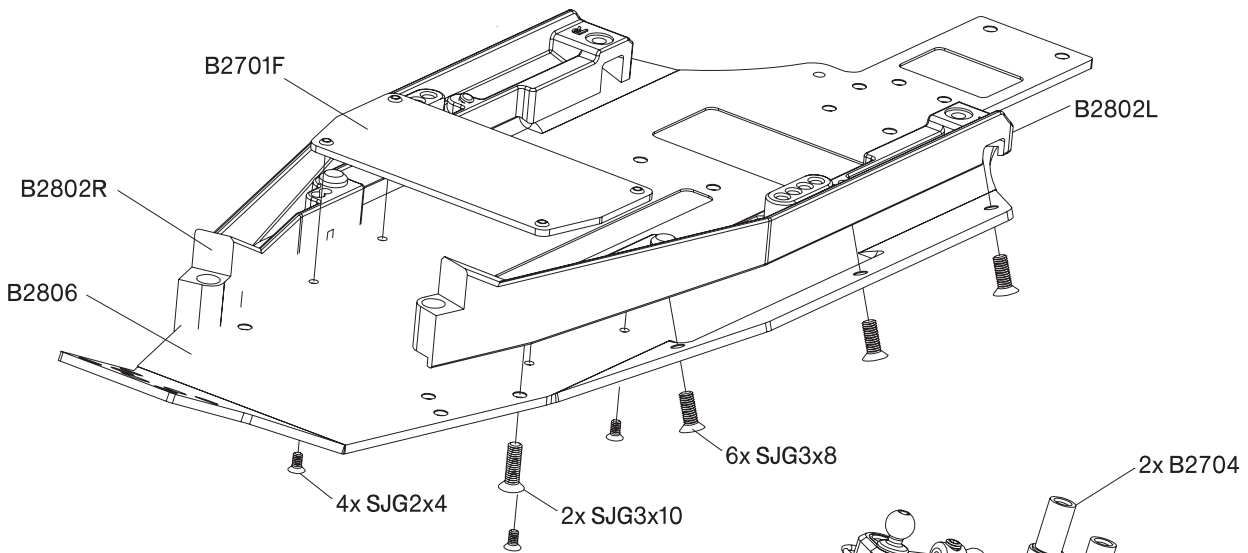

Step 3-3 / Bag C1

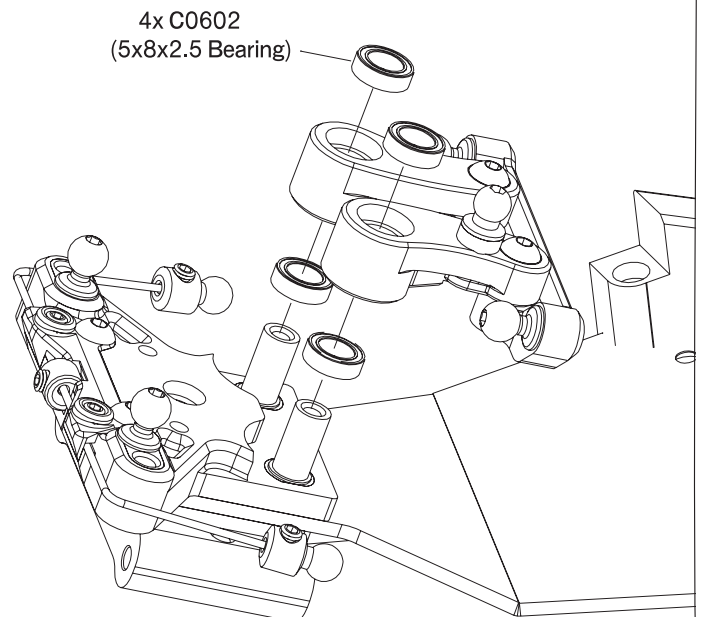
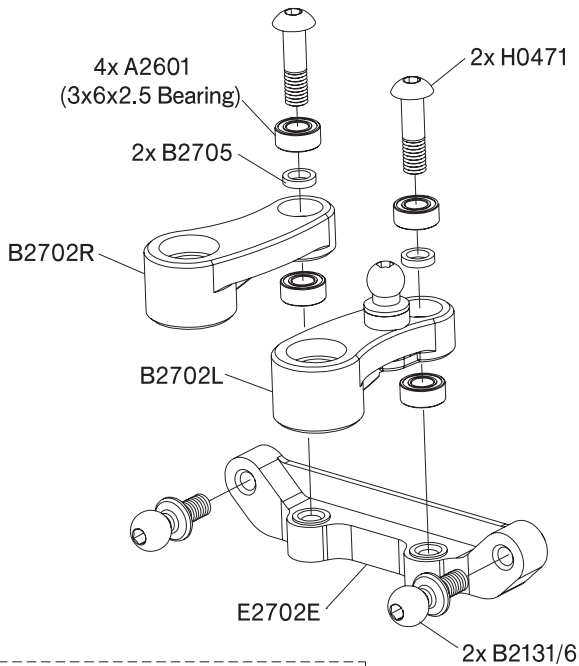
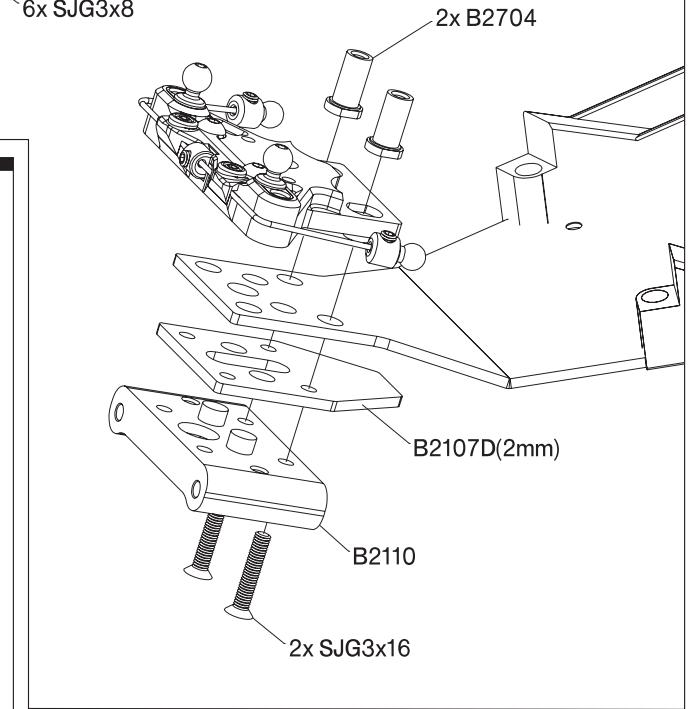
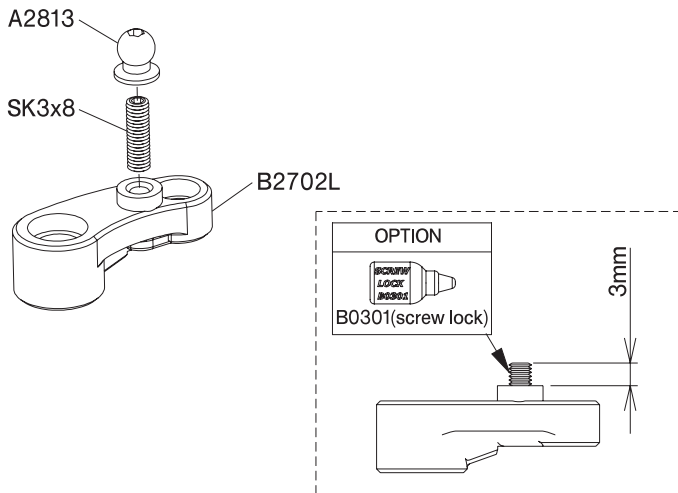

If B2702L/R moves slowly,
loosen H0471 a little.
B2702L/Rの動きが渋い場合にはH0471を
少し緩めてください。

Step 3-4 / Bag C1

Guideline for servo spacers

| | |
|----------|-----|
| Futaba | 2mm |
| KO PROPO | 1mm |
| MKS | 3mm |
| Protek | 0mm |
| Sanwa | 3mm |

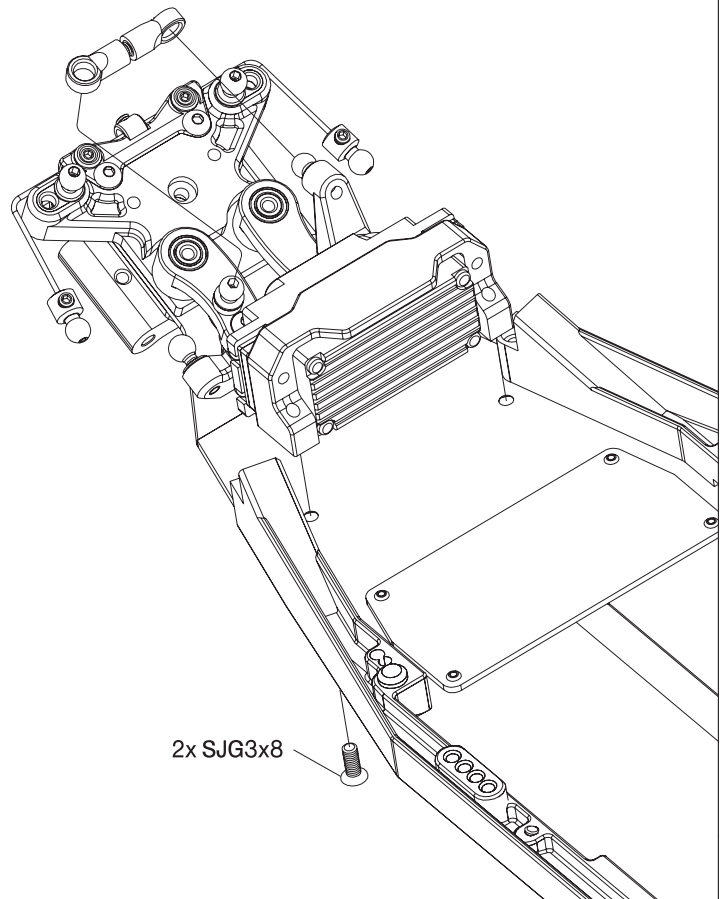
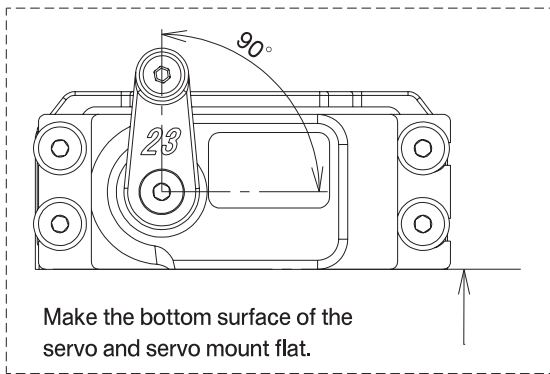
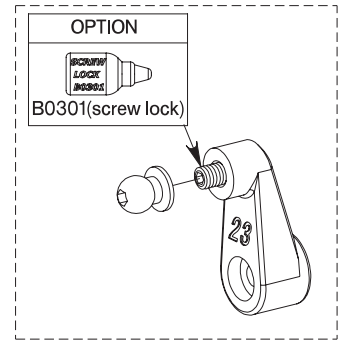
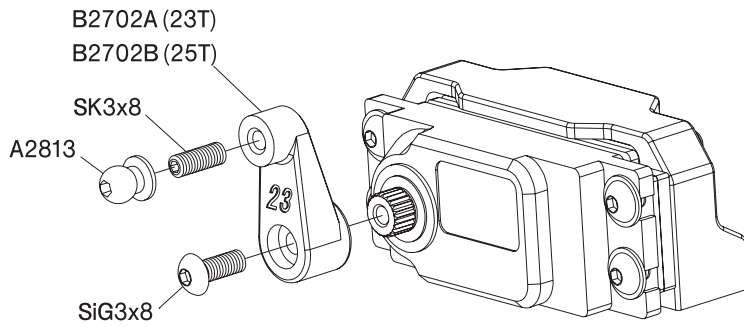
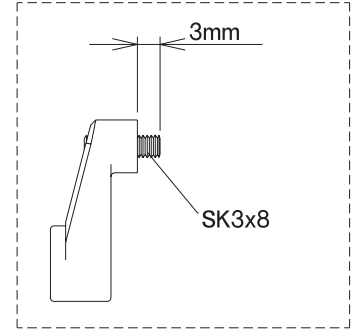
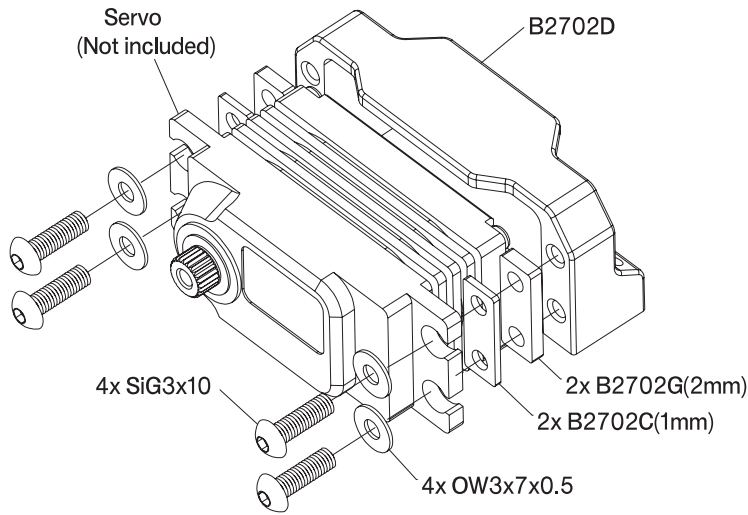

Step 3-5 / Bag C1

*Fit A2811 into B2101

If it is still loose after pushing it in with your fingers, use glue to secure it.

A2811をB2101に押し込みます。
外れる場合には接着剤で接着してください。

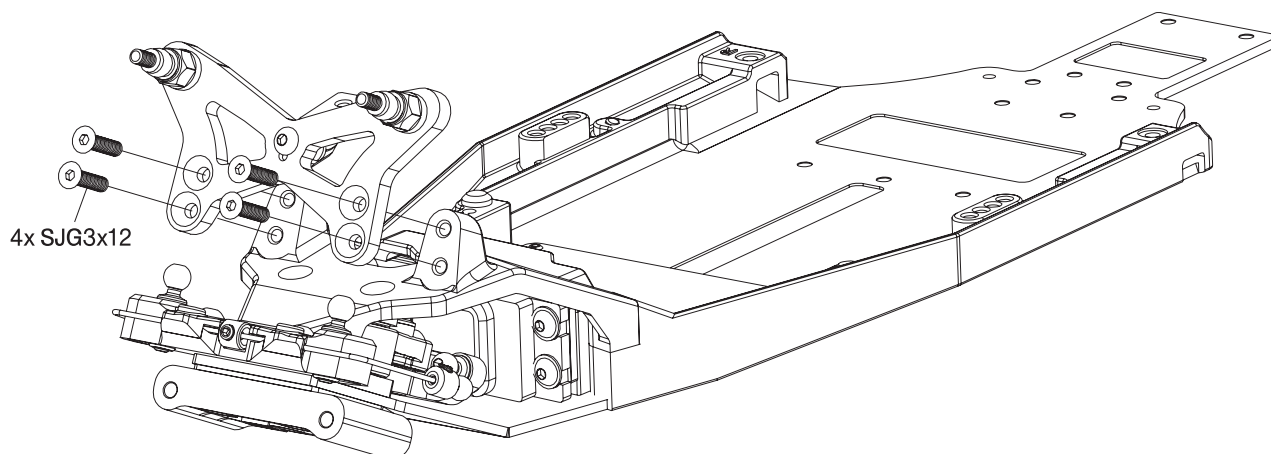
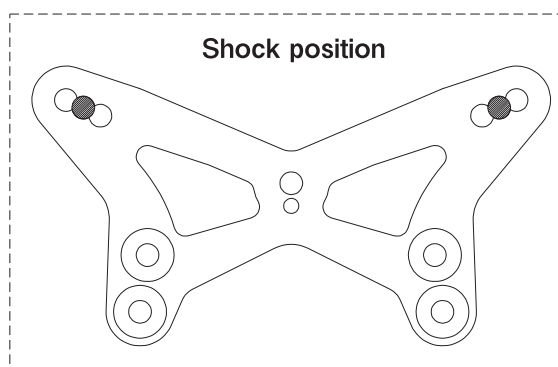
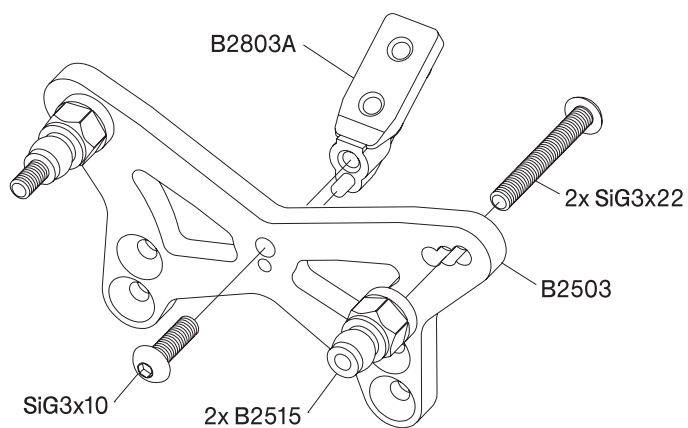
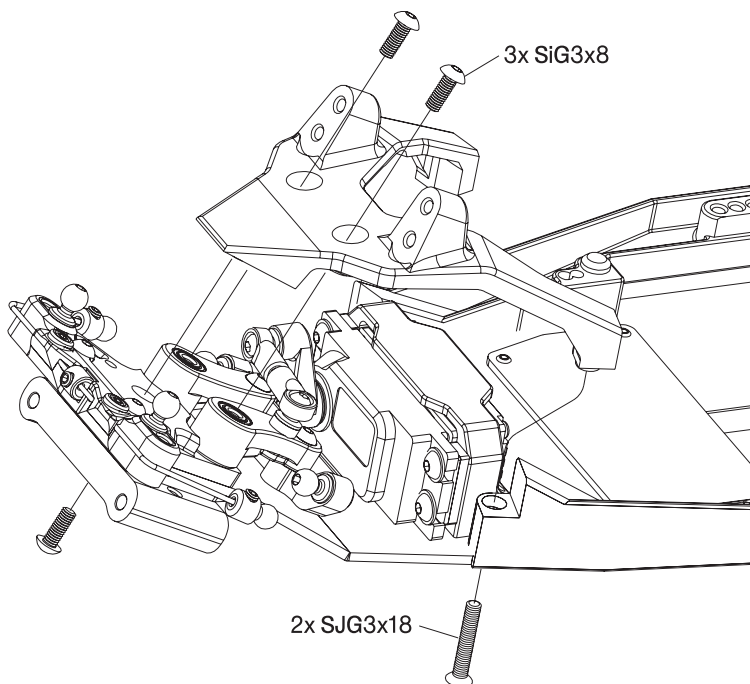
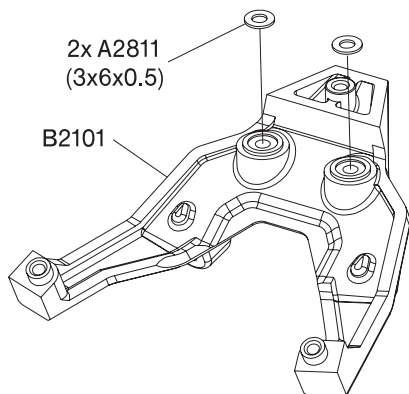

Step 4-1 / Bag D1

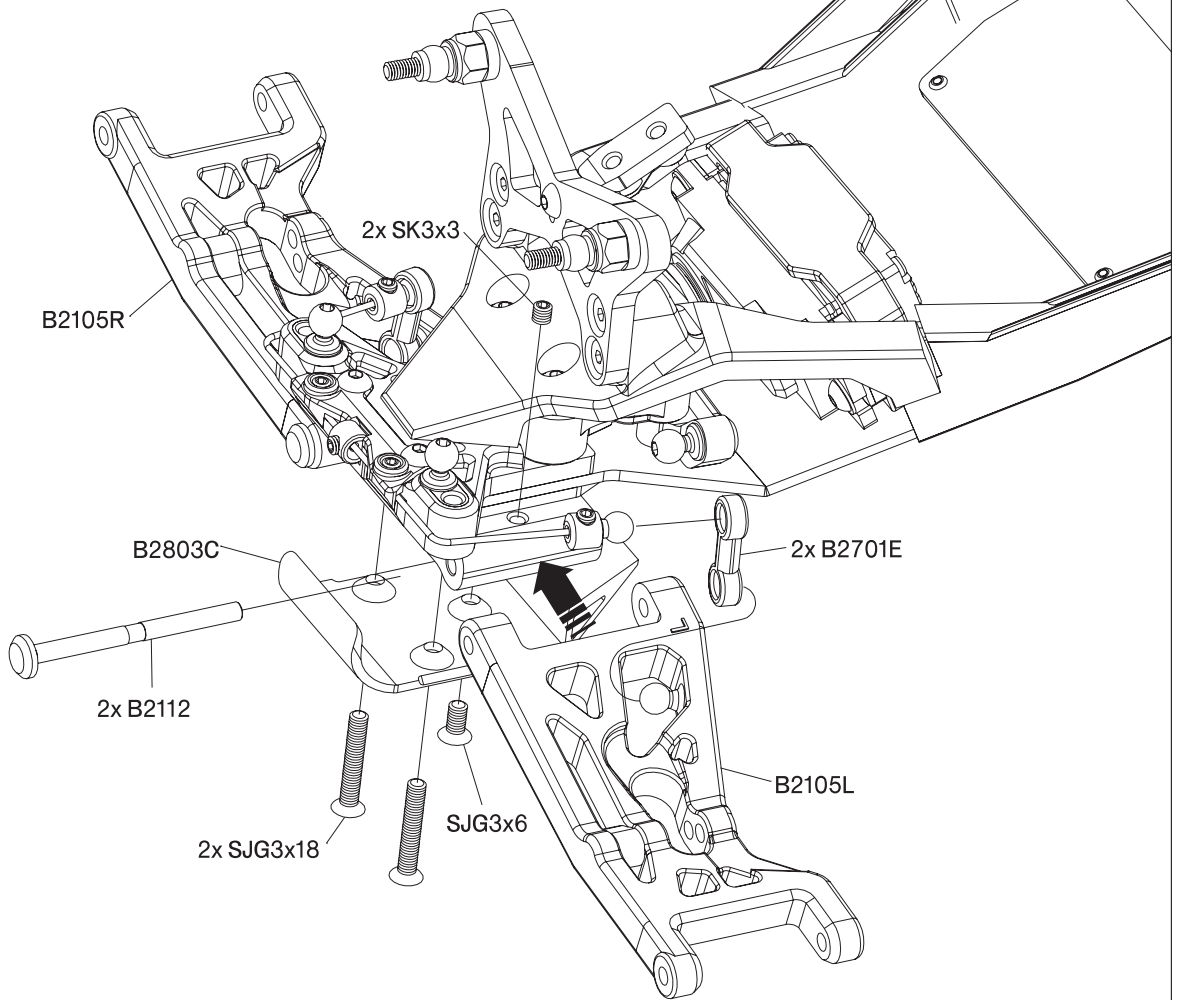

Right

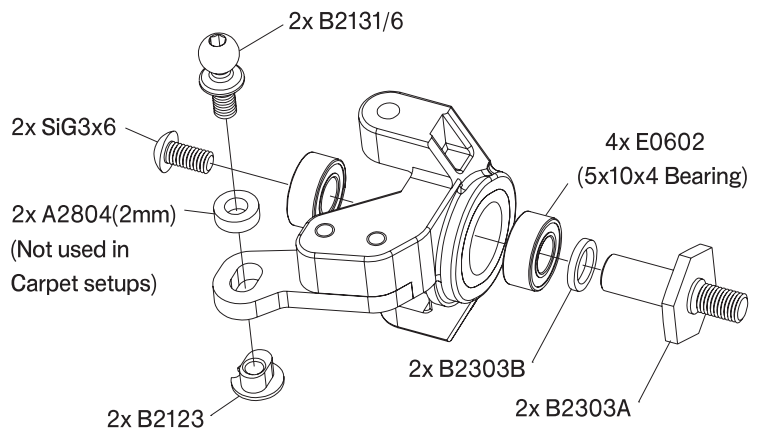
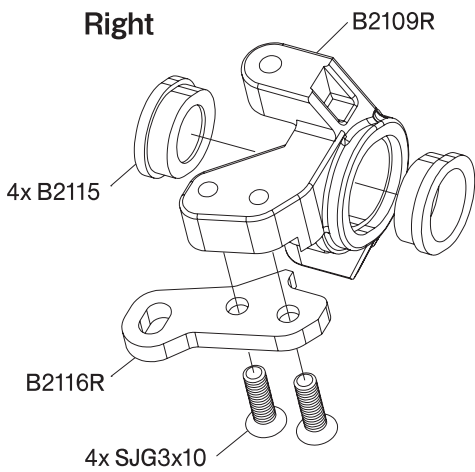

Left

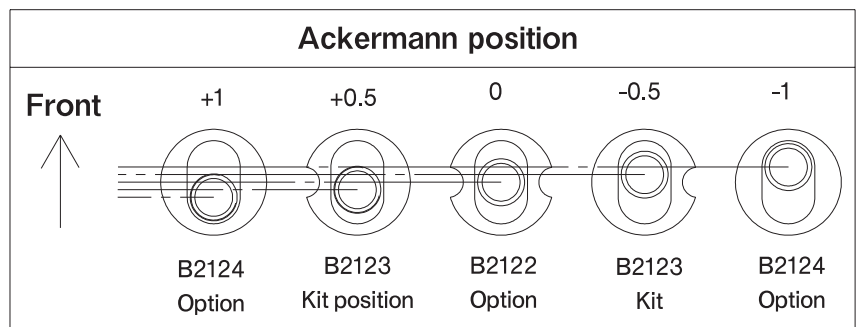
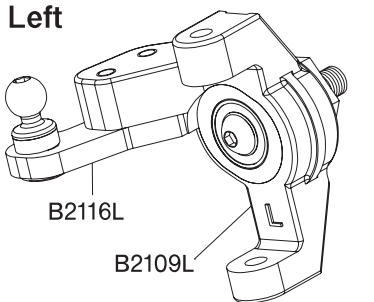

Step 4-2 / Bag A1, D1

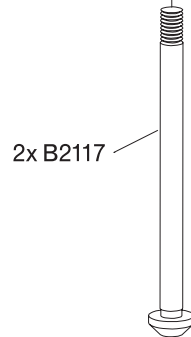
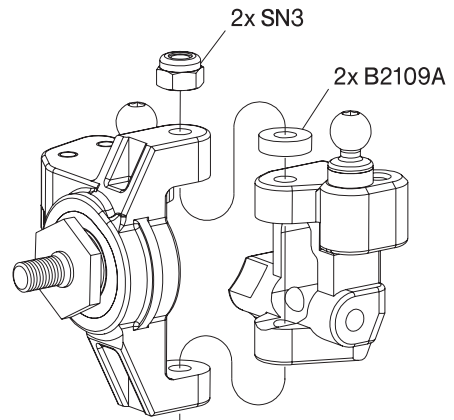
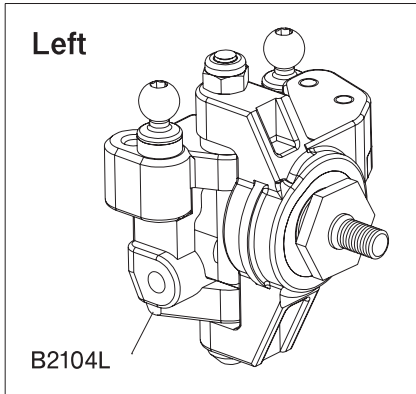
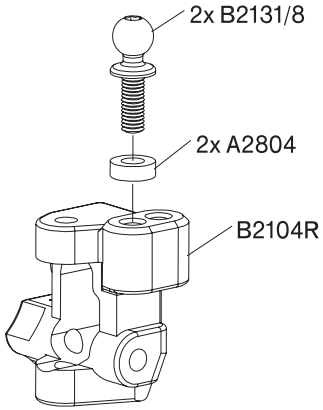

Axle height can be adjusted by moving the B2109A top or bottom. In a Carpet setup, B2109A is used at the top.

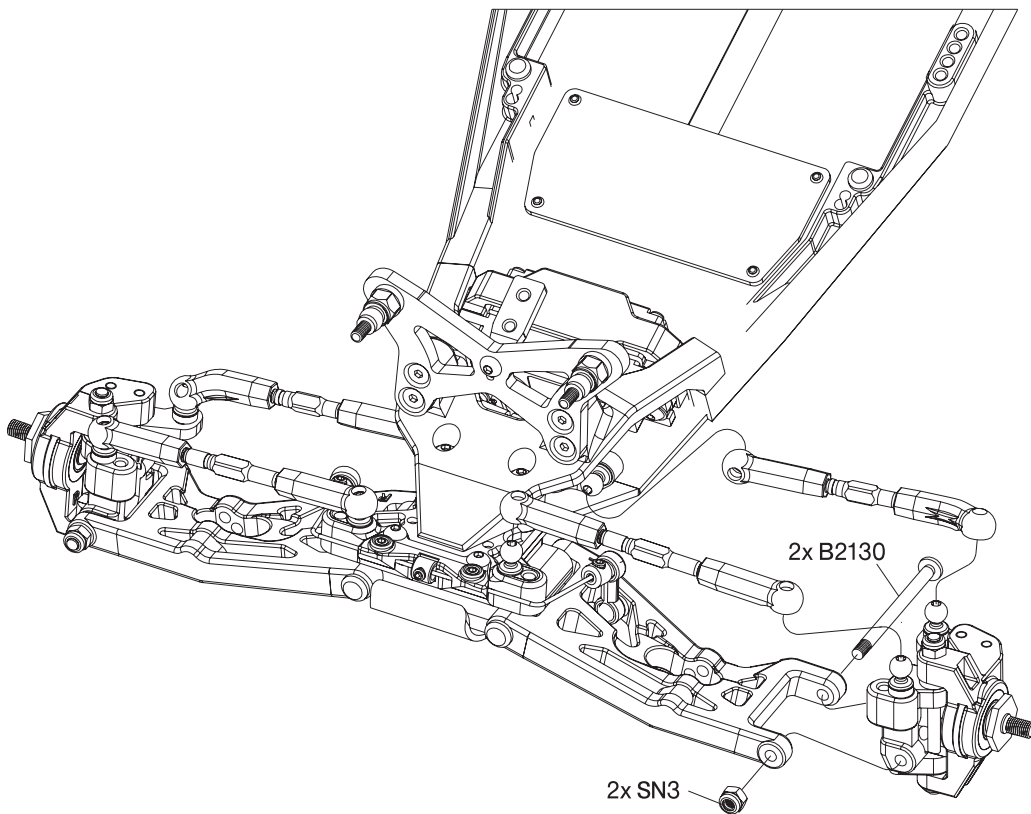

Step 5-1 / Bag A1, E1

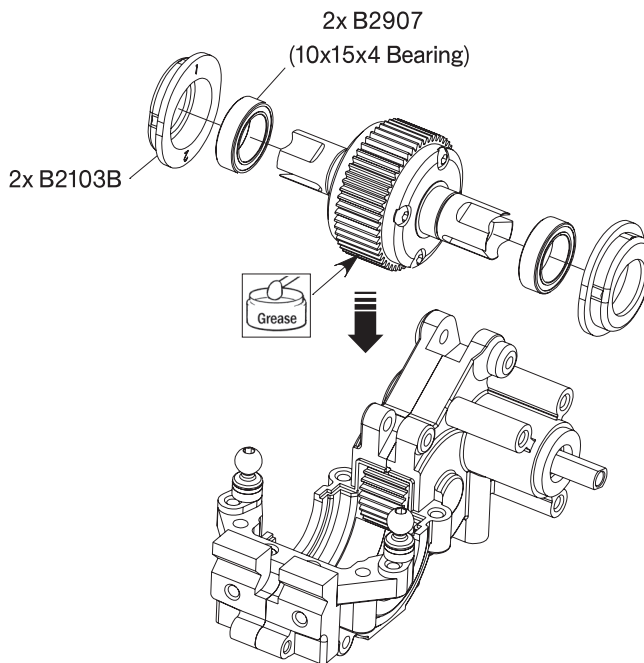
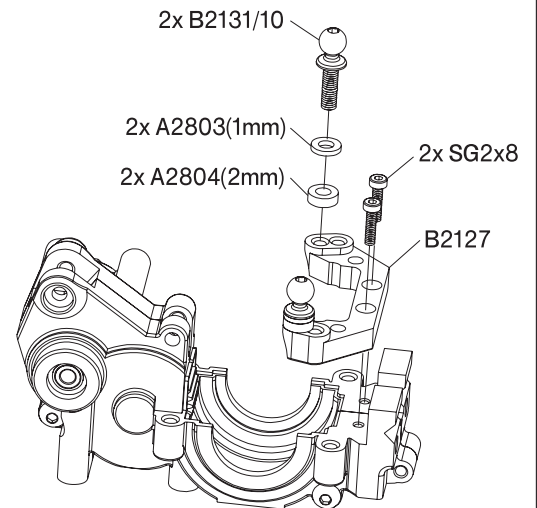
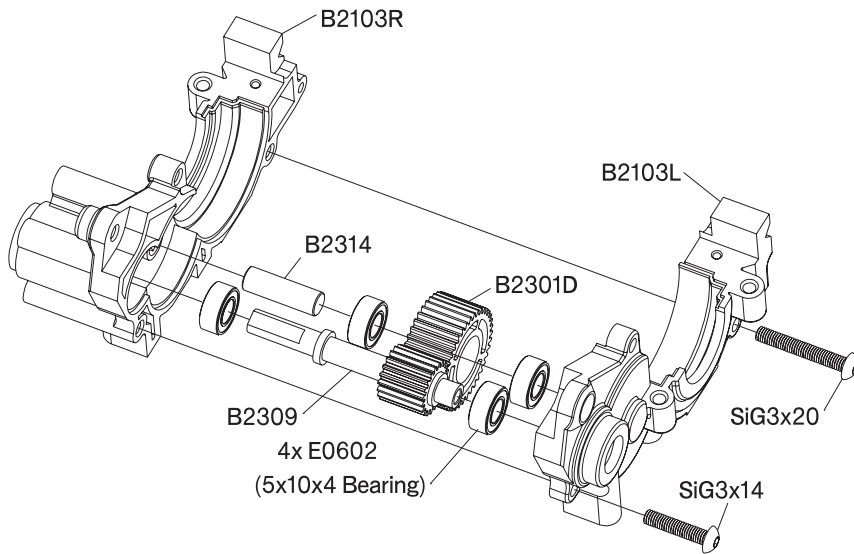

| | |
|--|----|
| | +3 |
| | +2 |
| | +1 |
| | 0 |

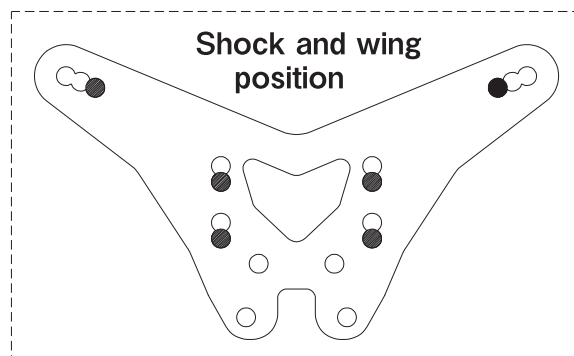
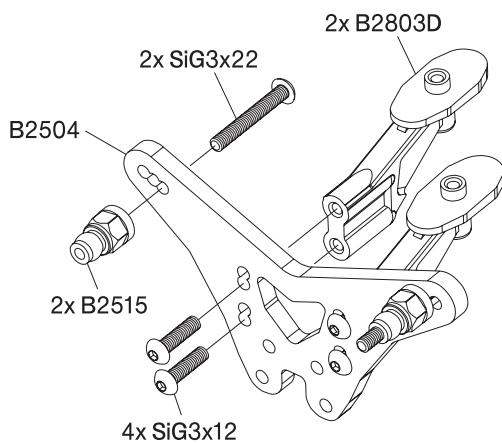

Step 5-2 / Bag E1

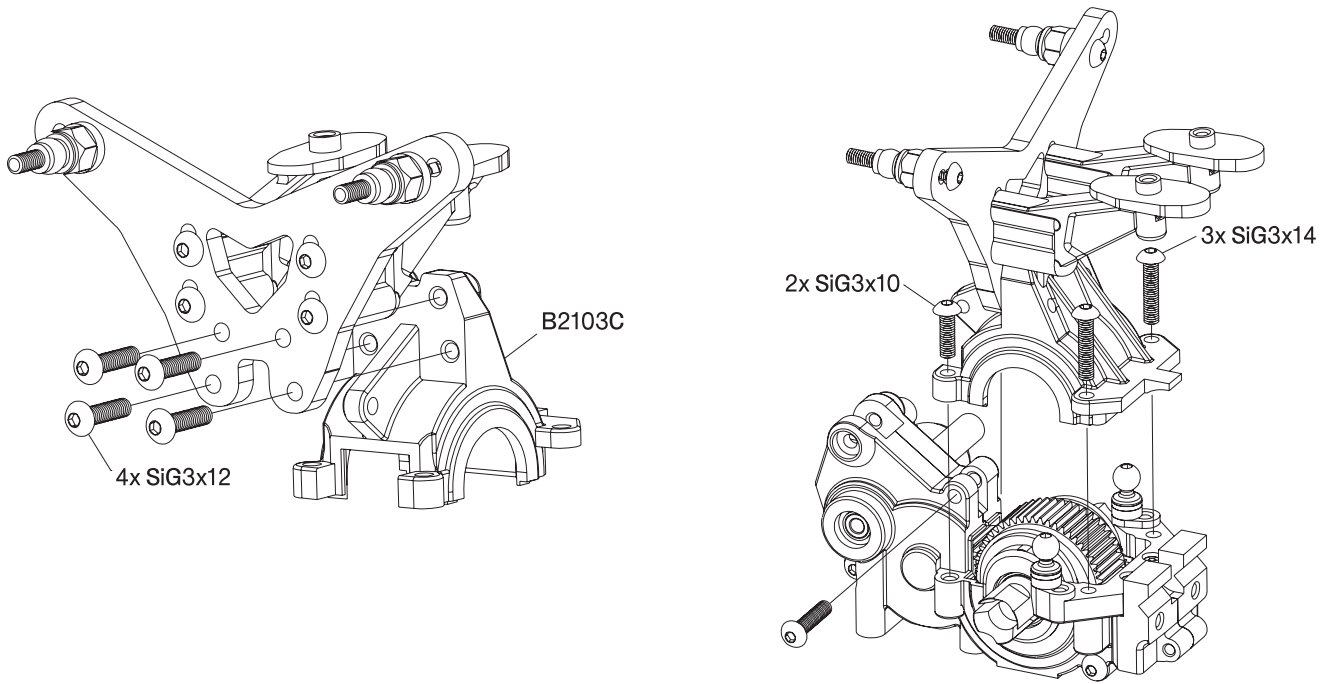

Step 5-3 / Bag F1

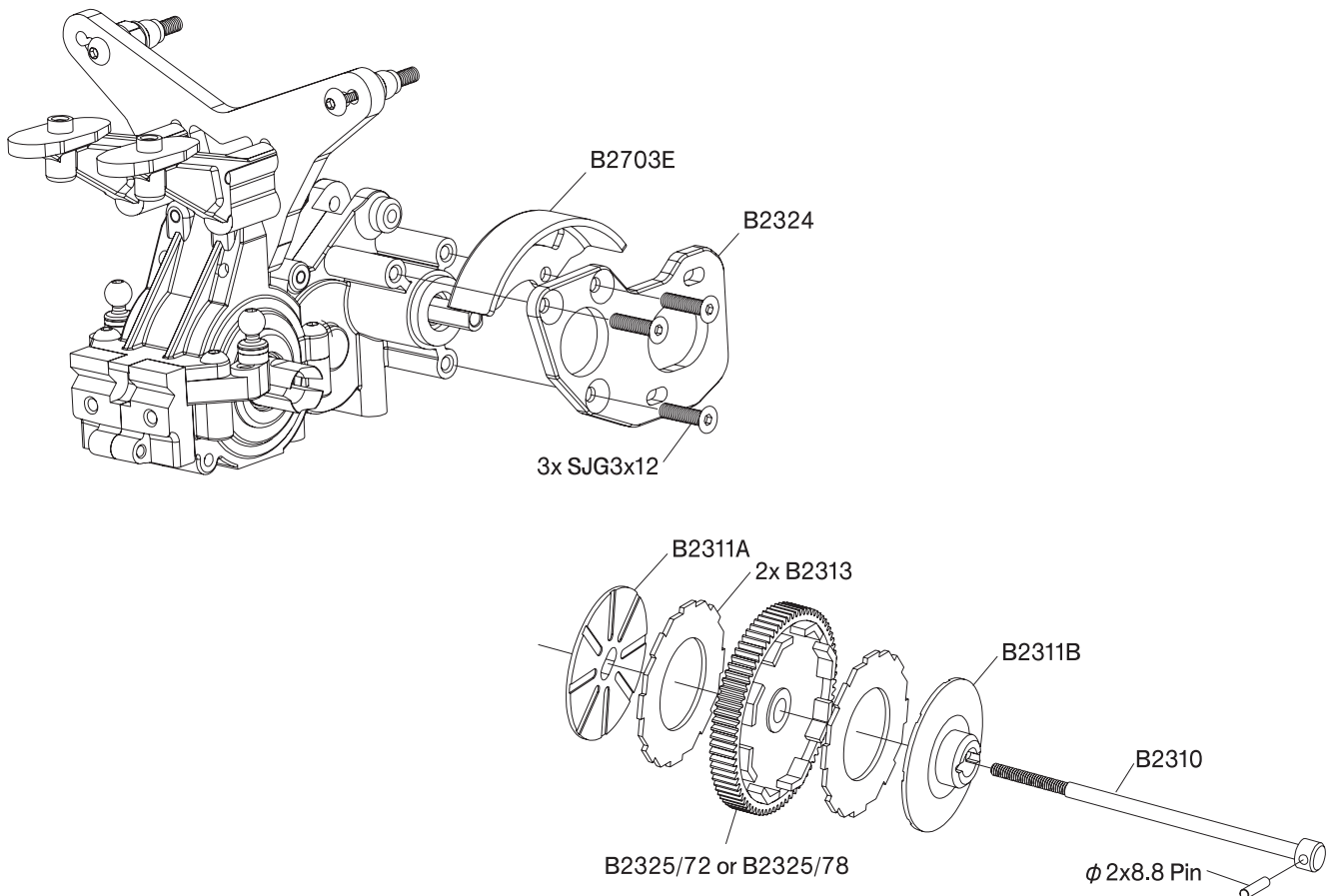

Step 5-4 / Bag F1

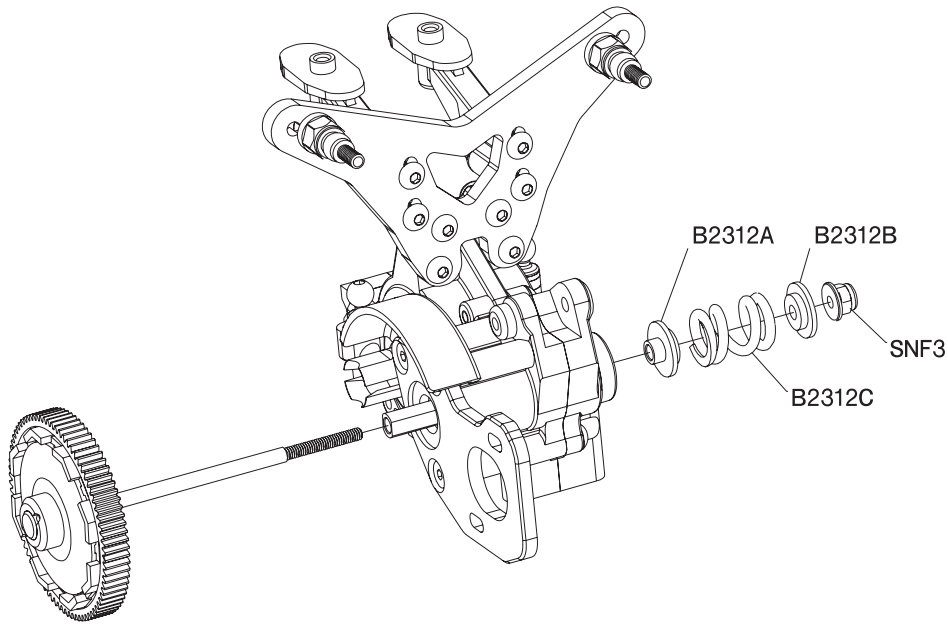

Attention to the orientation

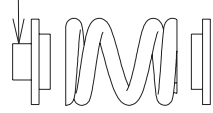

Step 5-5 / Bag F1

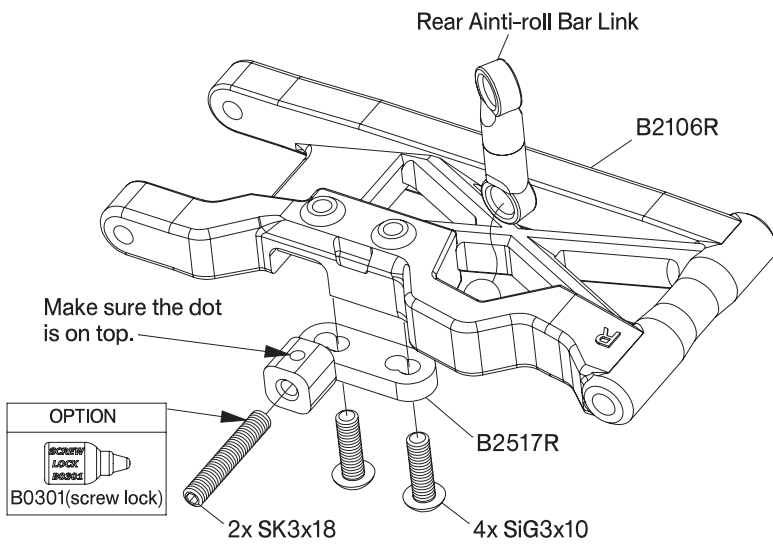

OPTION
B0301(screw lock)

Shock Position

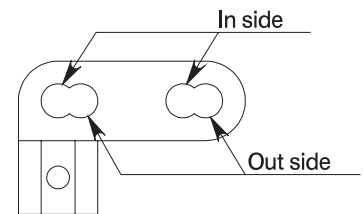

Dirt : Inside
Carpet : Outside

Left

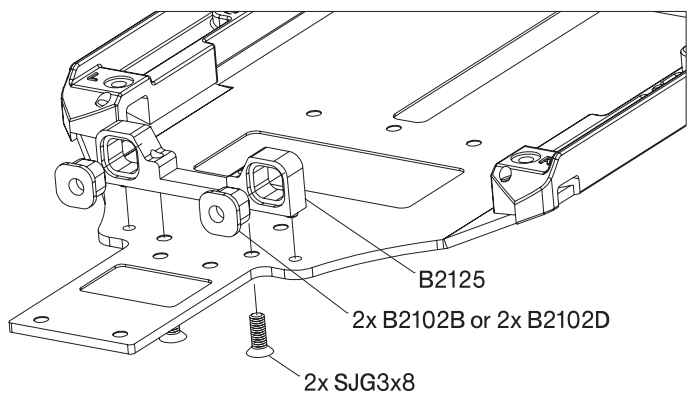
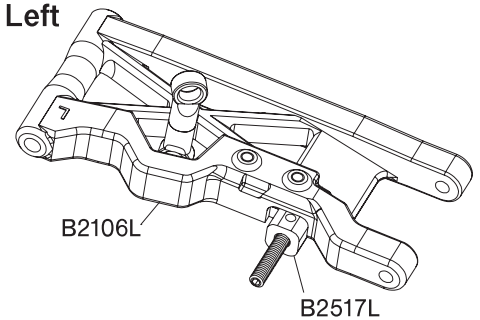

Dirt (B2102B)

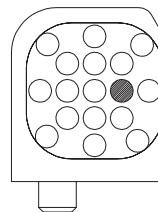

Carpet (B2102D)

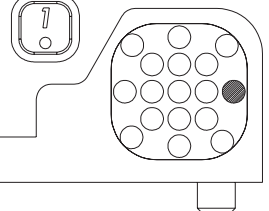
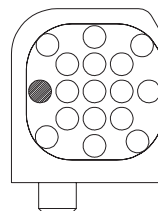

Step 5-6 / Bag F1

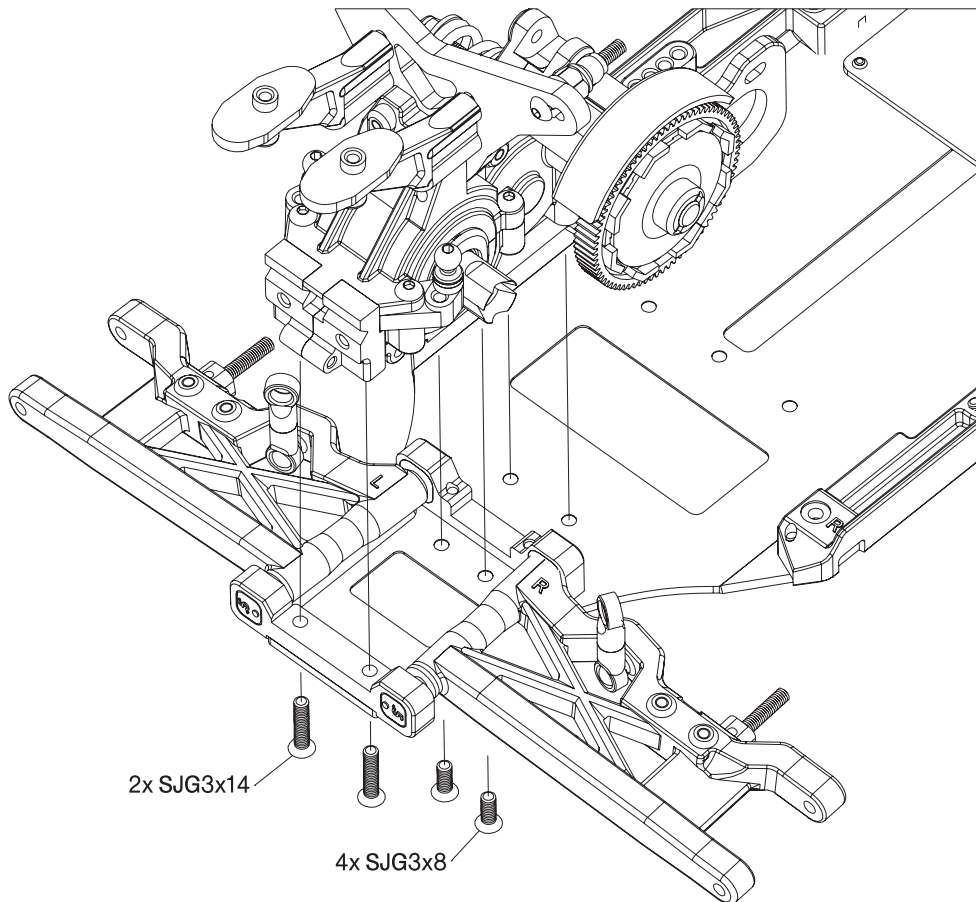
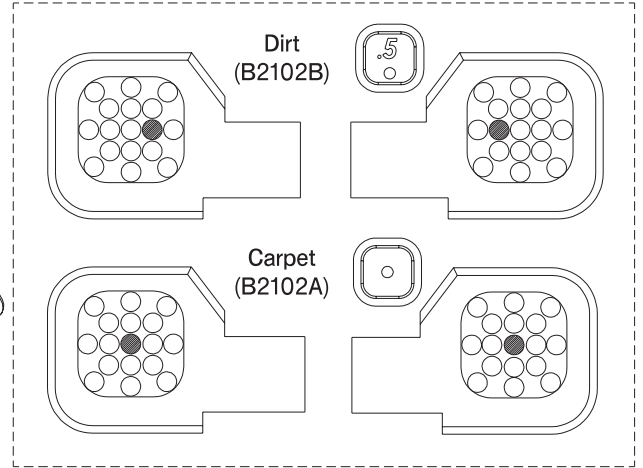
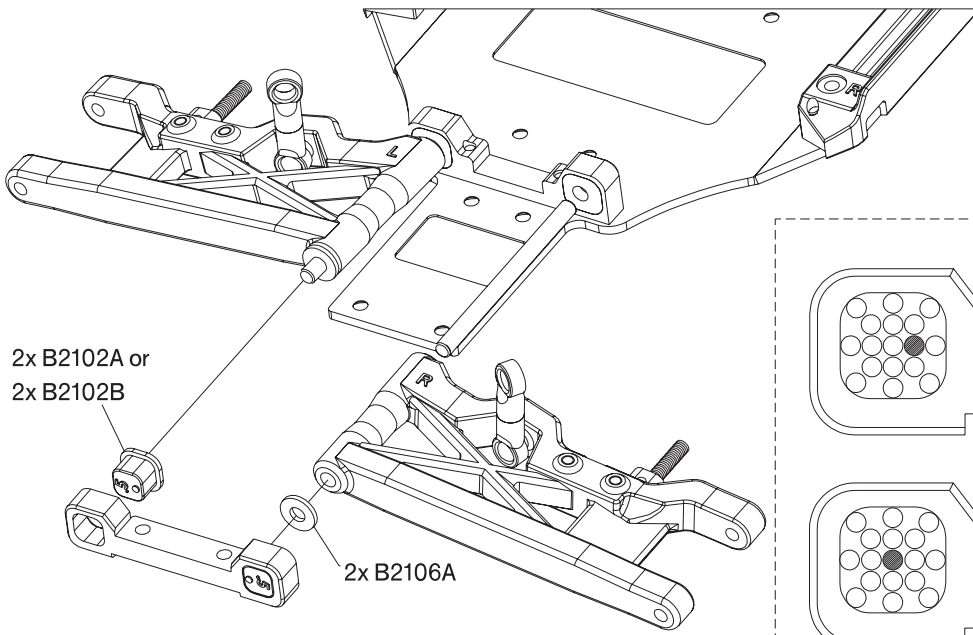

Step 6-1 / Bag G1

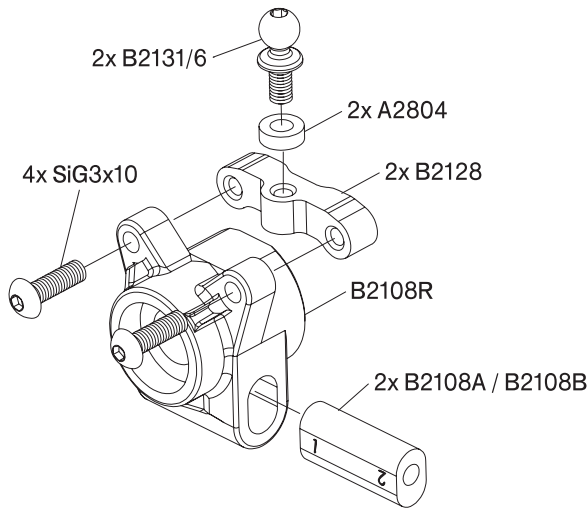

Rear Axle Height

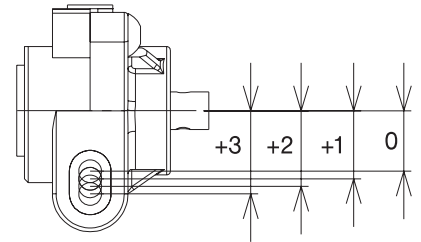

+3

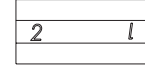

+2

Carpet

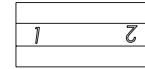

+1

Dirt

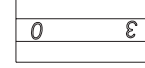

0

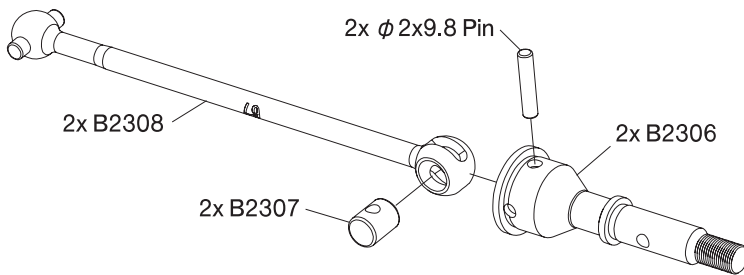

Joint Position

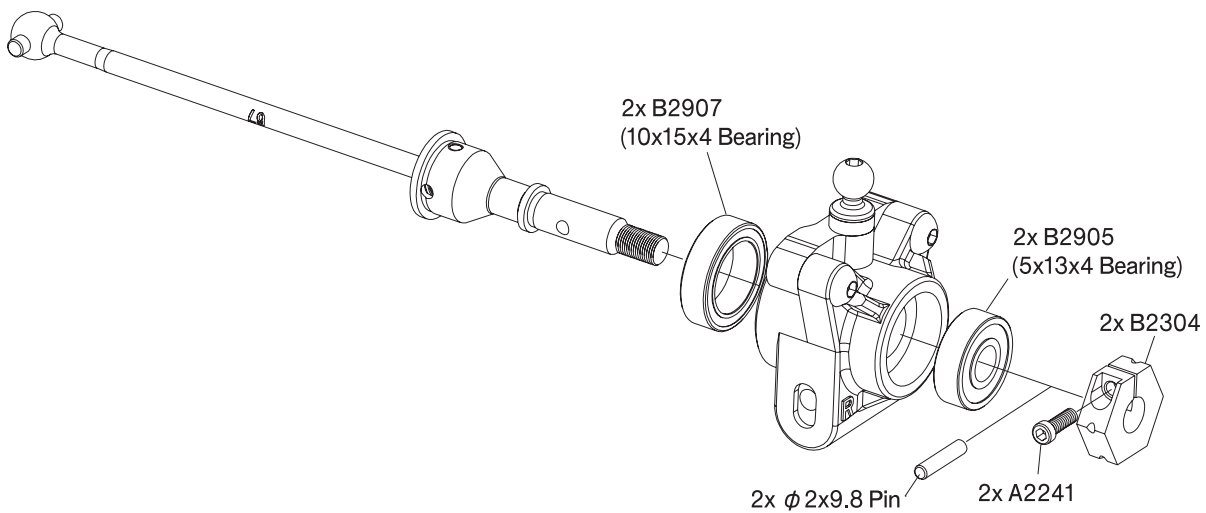
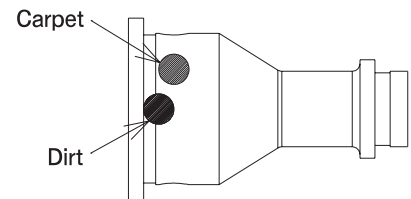

Left

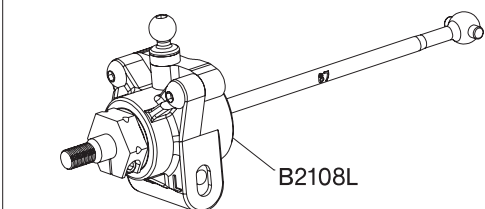

Step 6-2 /Bag G1

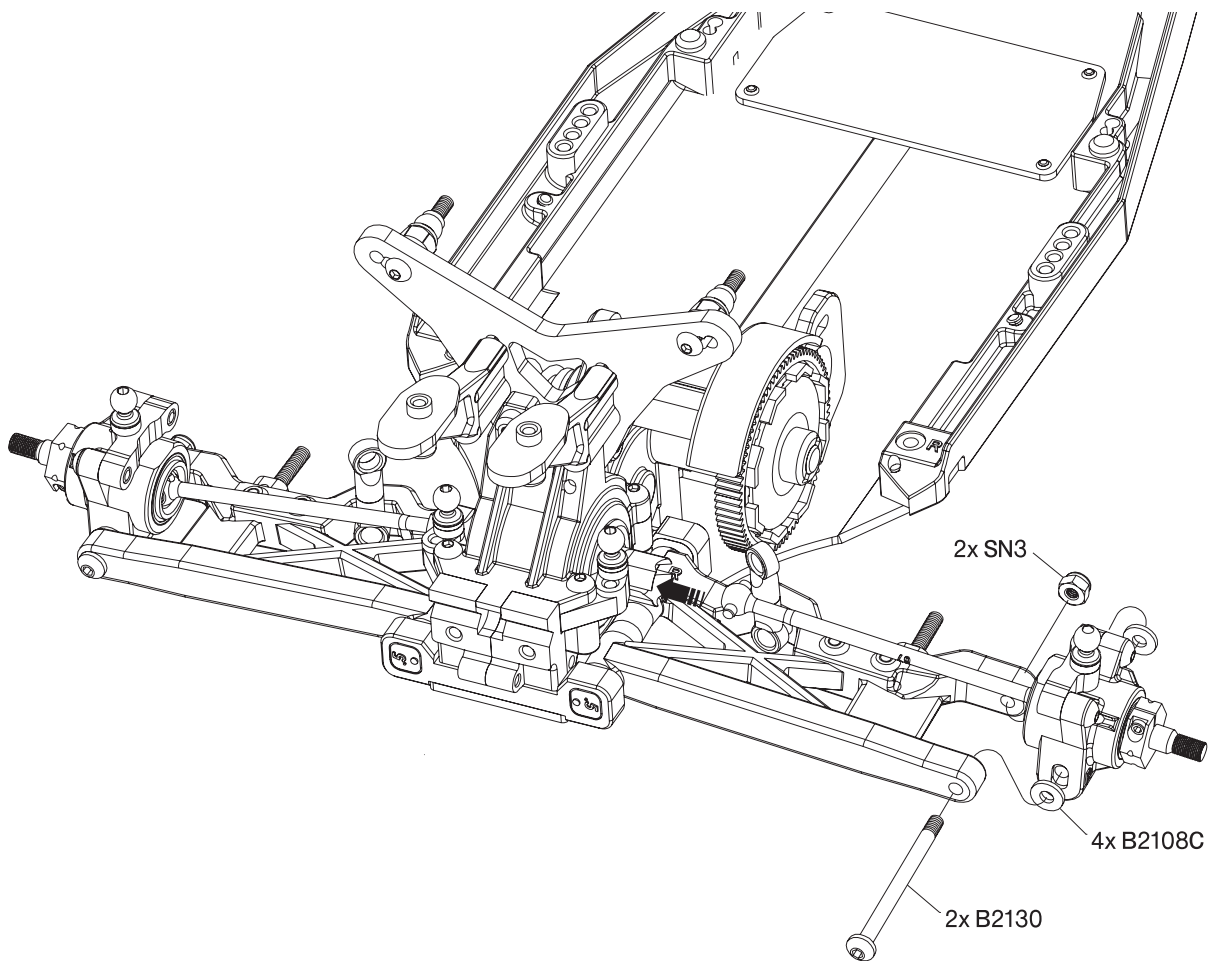

Step 6-3 /Bag G1

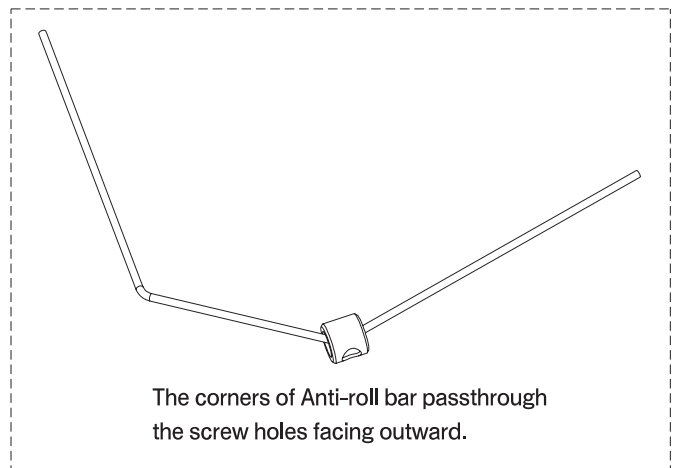
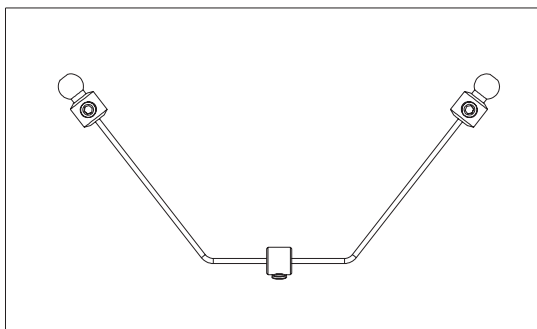
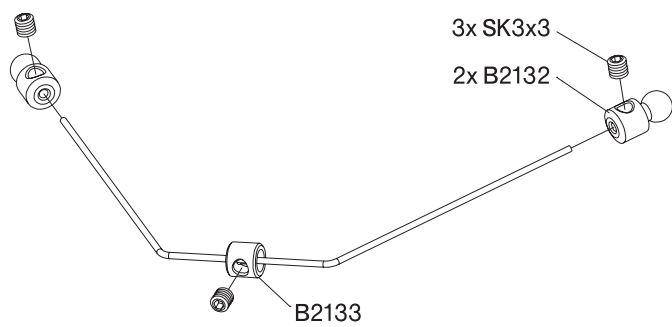

Step 6-3 / Bag G1

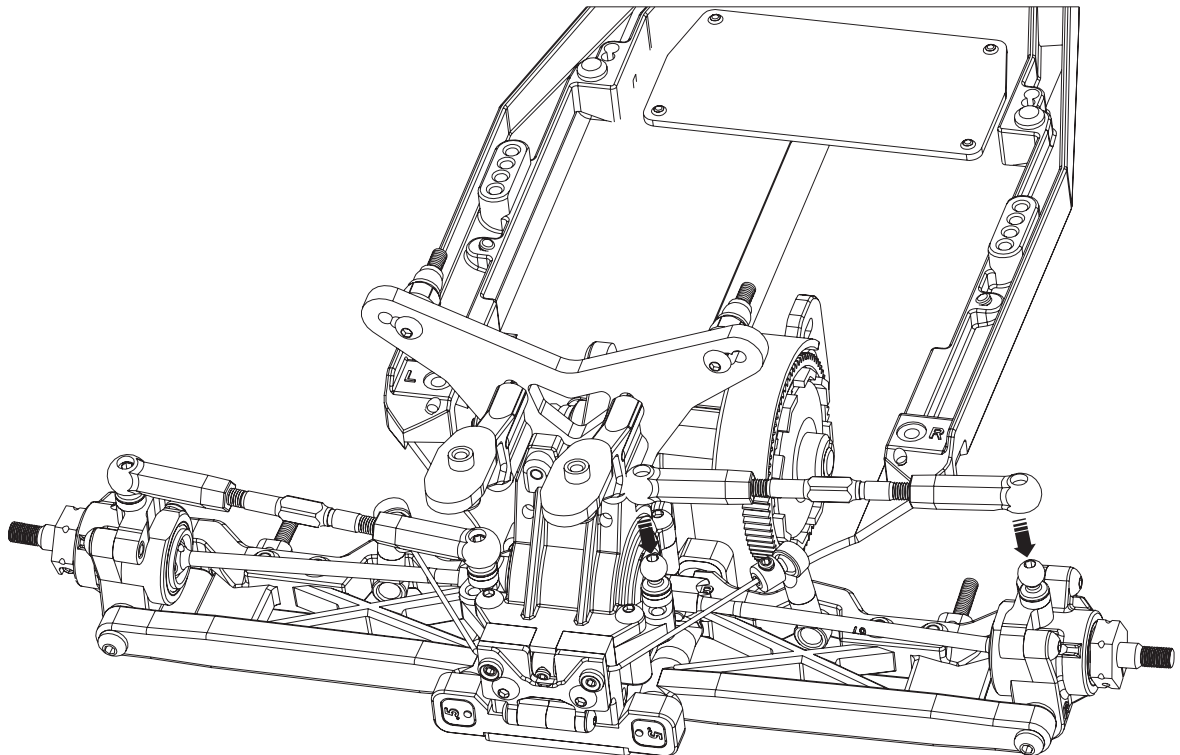
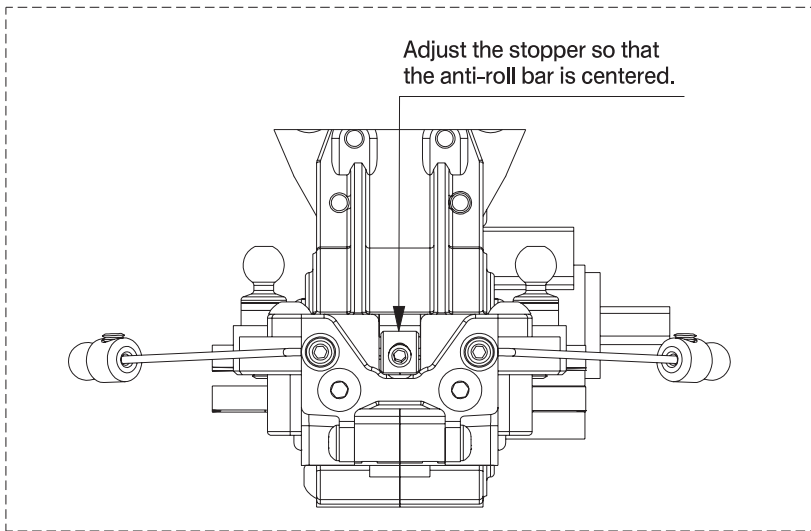
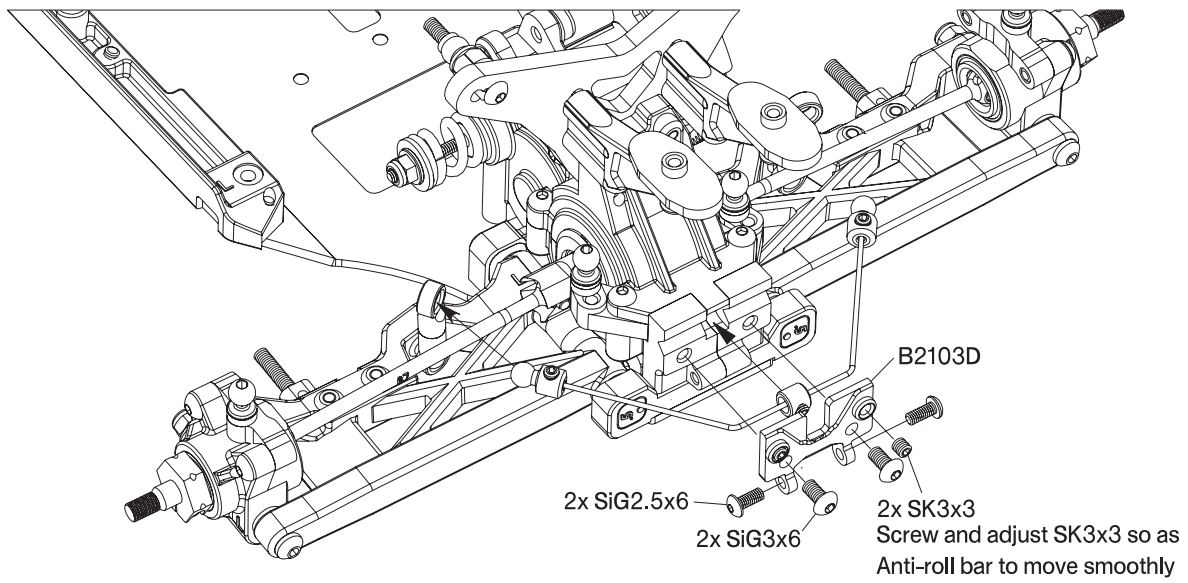

Stiffen

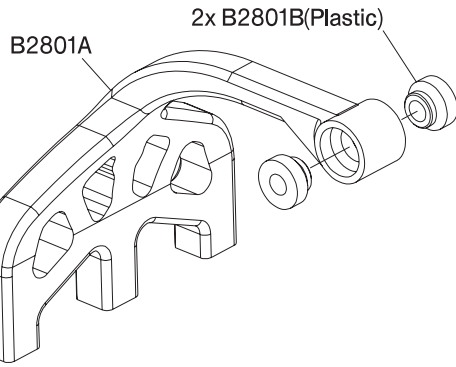

Softer

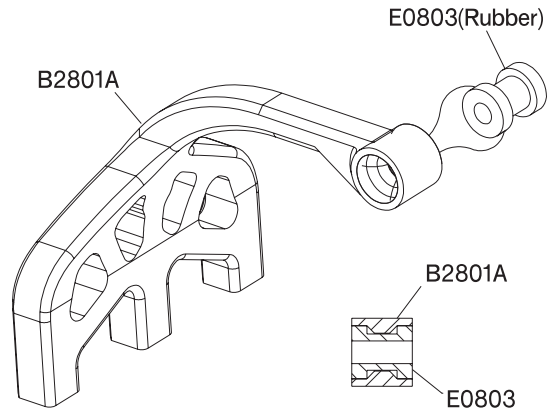

Chassis braces are stiffened with two screws.

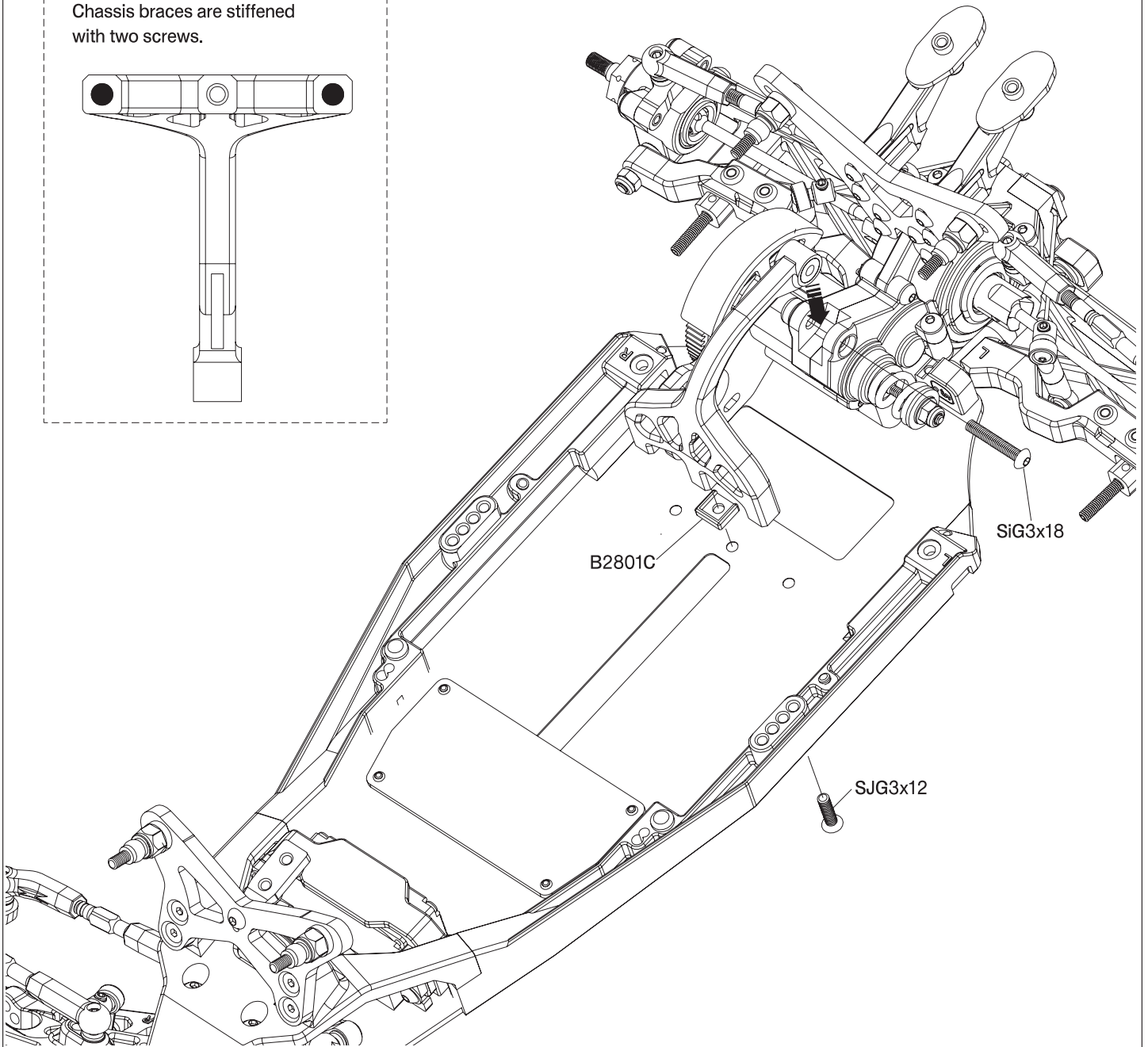
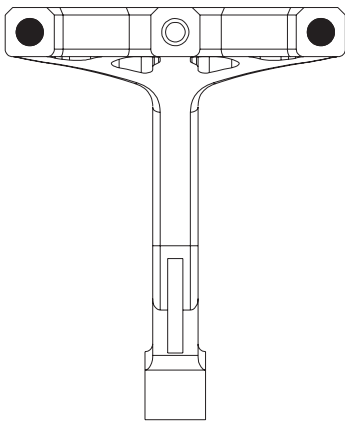

Step 7-2 / Bag G1

If the battery is 20mm or less,
do not use the spacer

2x SJG3x16or
2x SJG3x18

2x B2703D

2x B2703B(3mm)or
2x B2703C(6mm)

2x B2703A

MSB1 Gear Ratio Chart
(Transmission Ratio 2.6 : 1)

| Motor | Pinion | Spur | Final Drive Ratio |
|---------|--------|------|-------------------|
| 17.5 | 29 | 72 | 6.46 : 1 |
| | 30 | | 6.24 : 1 |
| | 31 | | 6.04 : 1 |
| | 32 | | 5.85 : 1 |
| 6.5/7.5 | 21 | 78 | 9.66 : 1 |
| | 22 | | 9.22 : 1 |
| | 23 | | 8.82 : 1 |

Motor
(Not included)

Pinion Gear
(Not included)

2x SiG3x8

Step 8-1 / Bag G1

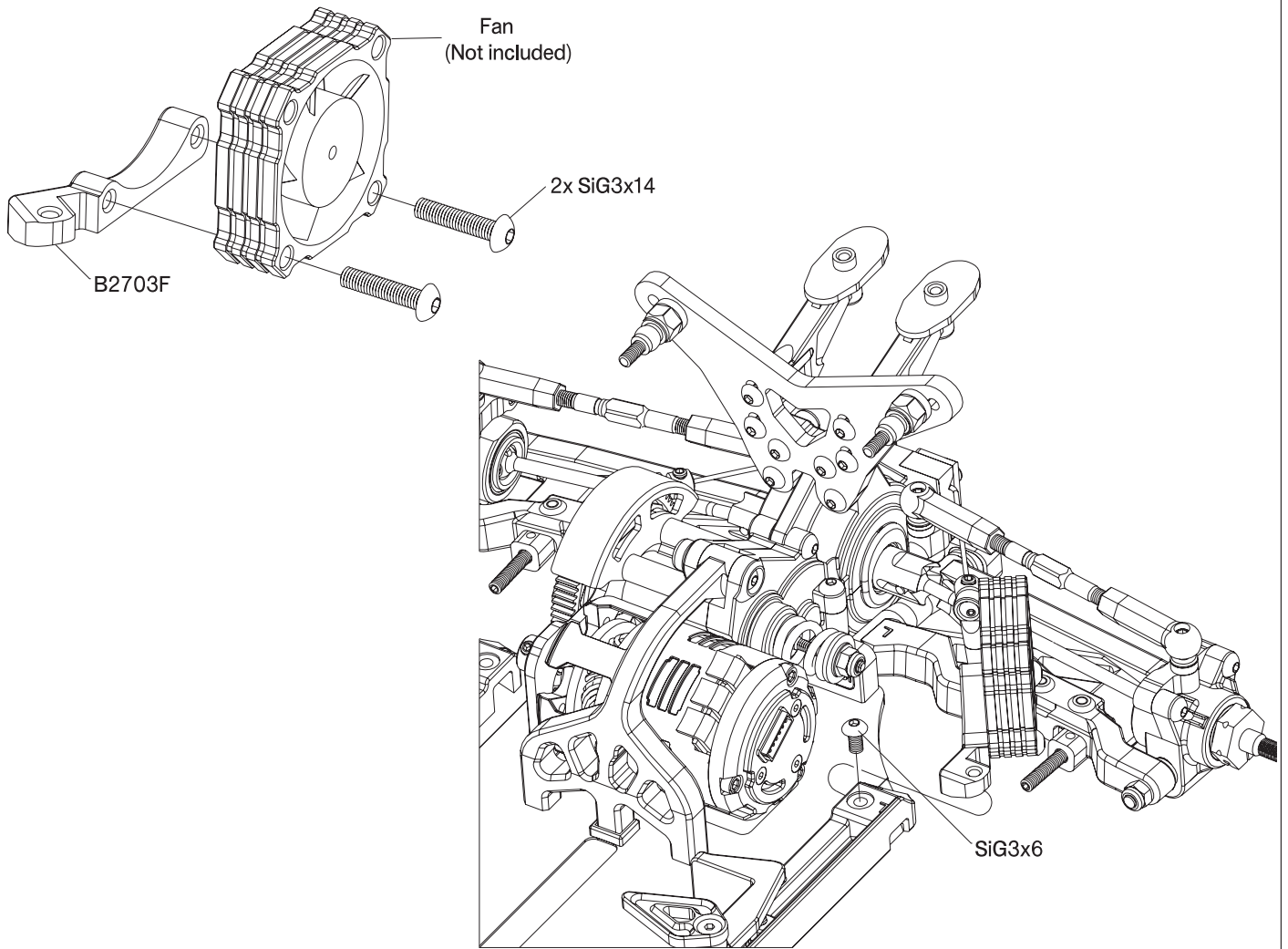

Step 8-2 / Bag G1

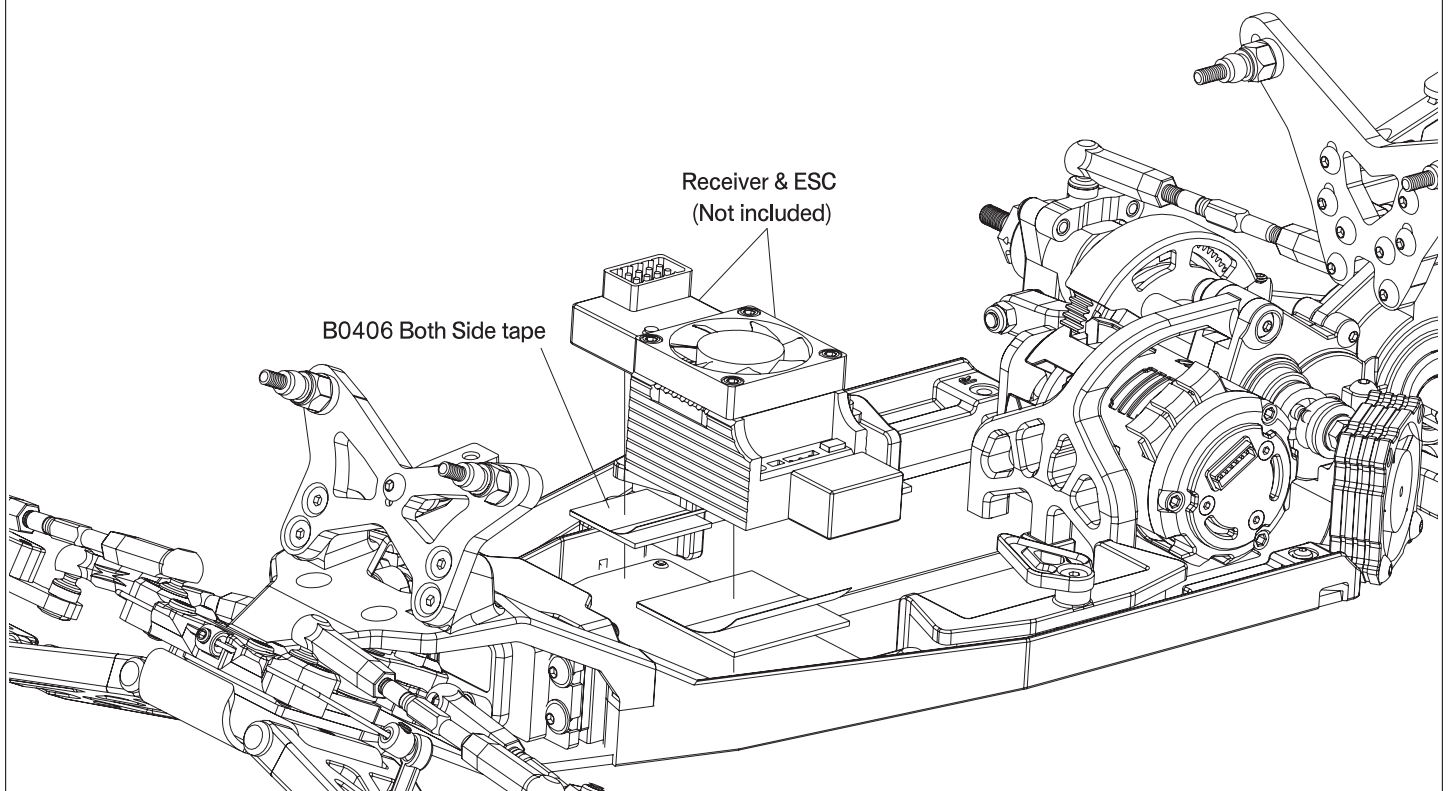

Step 9-1 / Bag H1

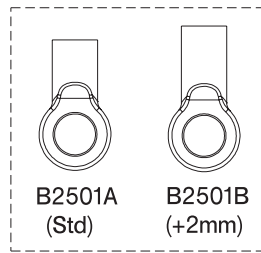
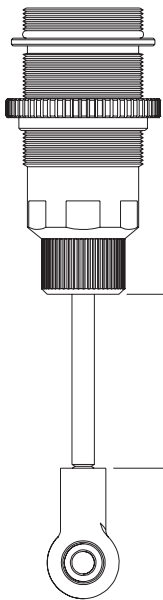
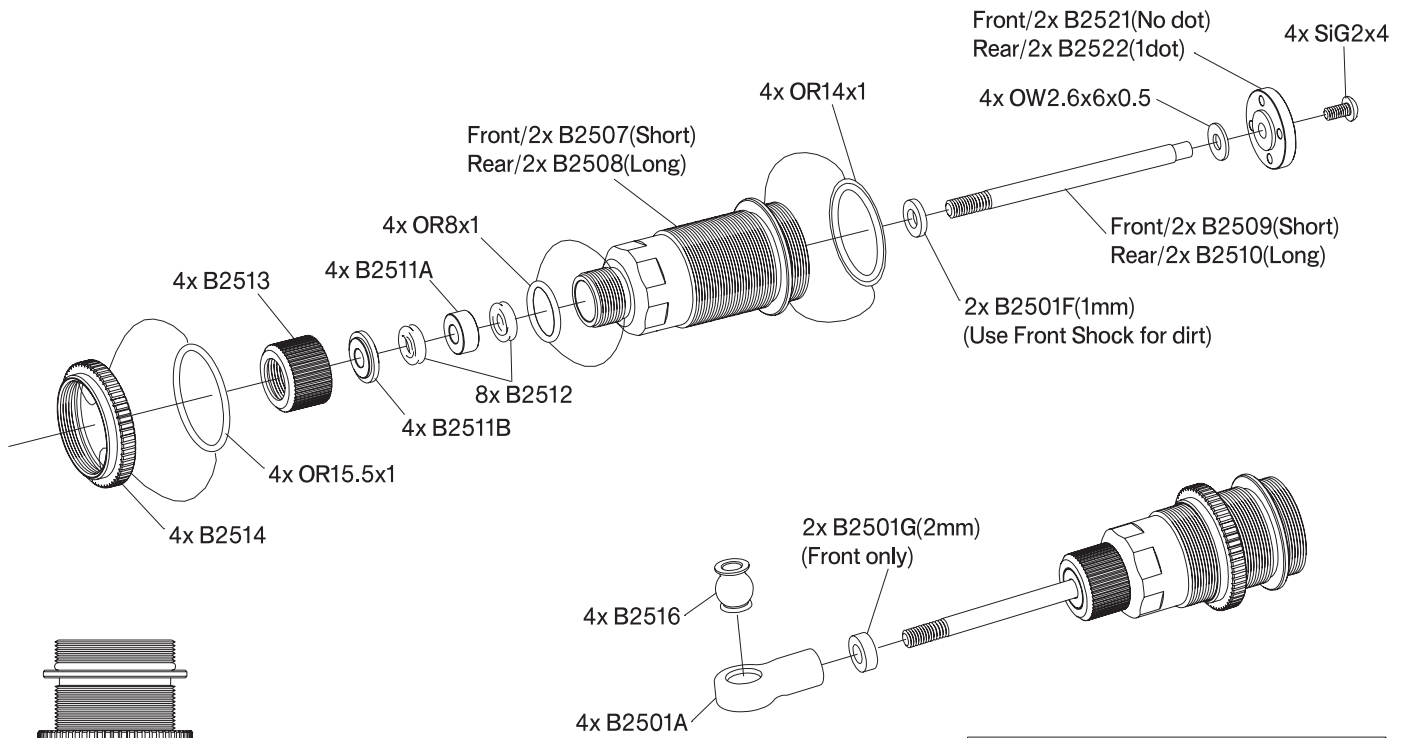

| Piston identification | |
|----------------------------|---|
| B2521 No dot | $\phi 1.6 \times 4$ |
| B2522 1dot | $\phi 1.7 \times 4$ |
| B2523 2dots (Option) | $\phi 1.7 \times 2+$ $\phi 1.8 \times 2$ |

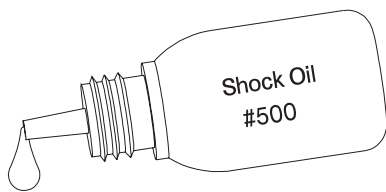

- 1) Fill up shock case with oil, slowly move the shock shaft up and down, and leave it for a while.
 - 2) Fill up a shock case with oil after air bubbles in the shock oil are removed.
- 1) ショックケースにオイルを満し、ショックシャフトを数回上下させ気泡が抜けるまで待ちます。
 2) ショックシャフトを一番下まで下げ、ショックケースの淵までオイルを入れ、ショックキャップを取り付けます。

- 3) Quickly push up the shock shaft to wipe off oils overflowed from the screws hole.
 - 4) Tighten SiG2x4 while pushing the shock shaft up to the top.
- 3) ショックシャフトを素早く最上部まで上げ、ネジ穴から出てくるオイルを拭き取ります。
 4) ショックシャフトが最上部の位置でSiG2x4を取り付けます。

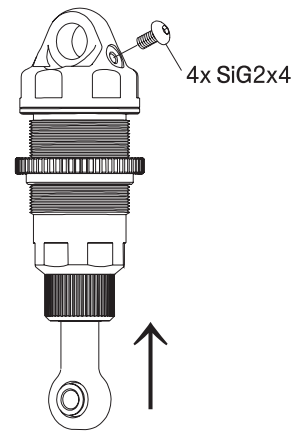
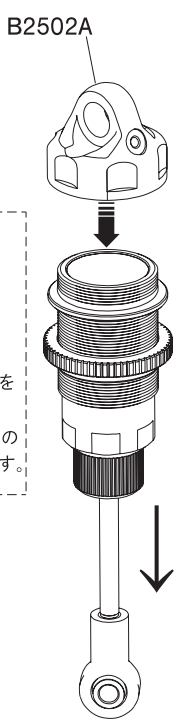
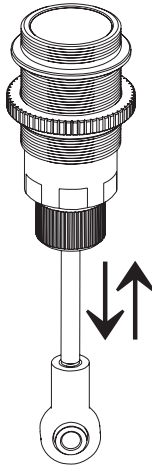

Step 9-2 / Bag H1

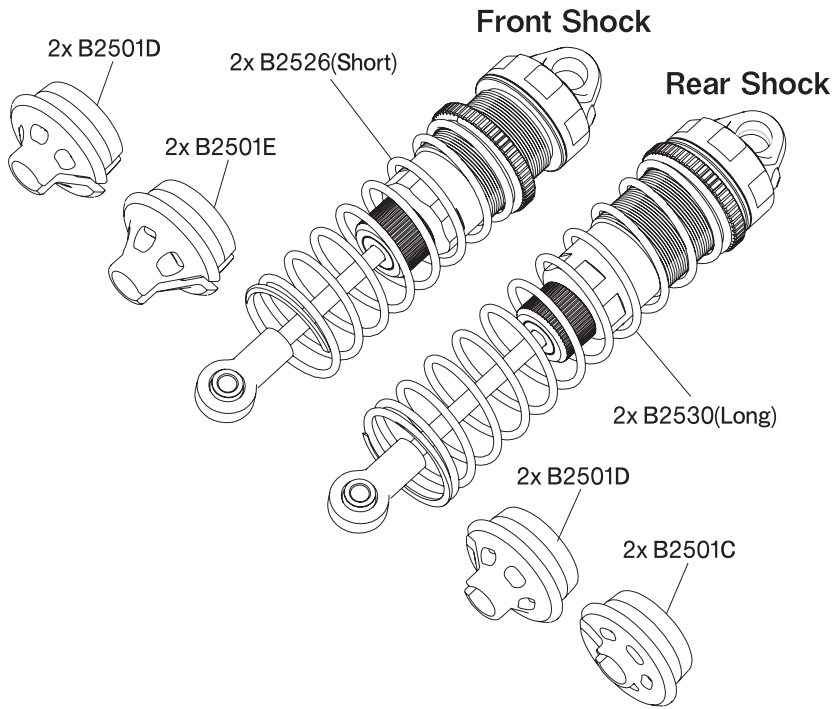

| | | |
|--------|---------------------------|------|
| ○B2525 | Front Shock Springs 1Dot | Soft |
| ●B2526 | Front Shock Springs 2Dots | ↕ |
| ○B2527 | Front Shock Springs 3Dots | Hard |
| ○B2528 | Front Shock Springs 4Dots | |
| ○B2529 | Rear Shock Springs 1Dot | Soft |
| ●B2530 | Rear Shock Springs 2Dots | ↕ |
| ○B2531 | Rear Shock Springs 3Dots | Hard |

●: Kit / ○: Option

Shock Spring Cup

Dirt : Front/B2501D
Rear/ B2501C

Carpet : Front/B2501E
Rear/B2501D

Step 10-1 / Bag H1

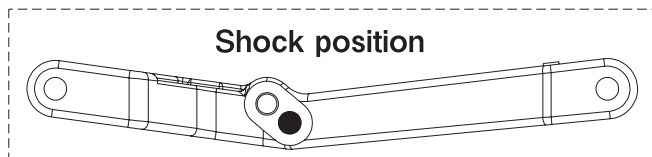
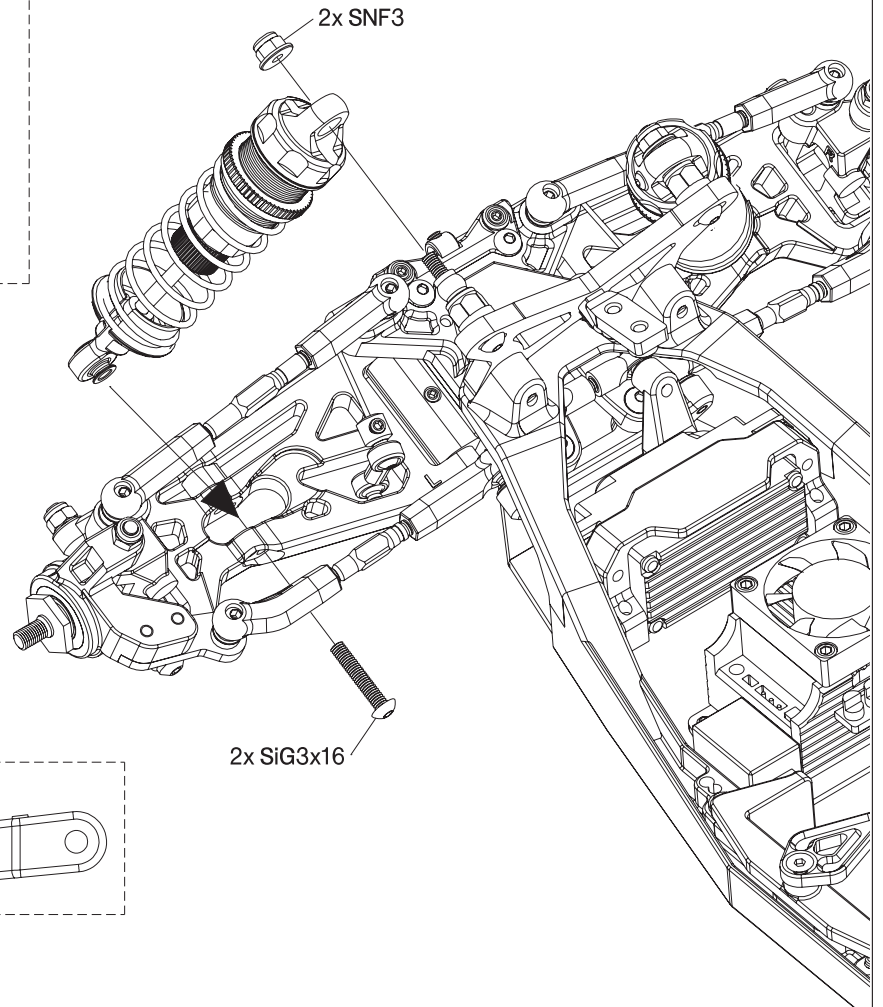
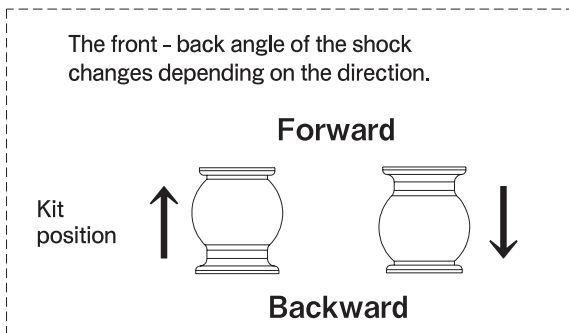

Step 10-2 / Bag H1

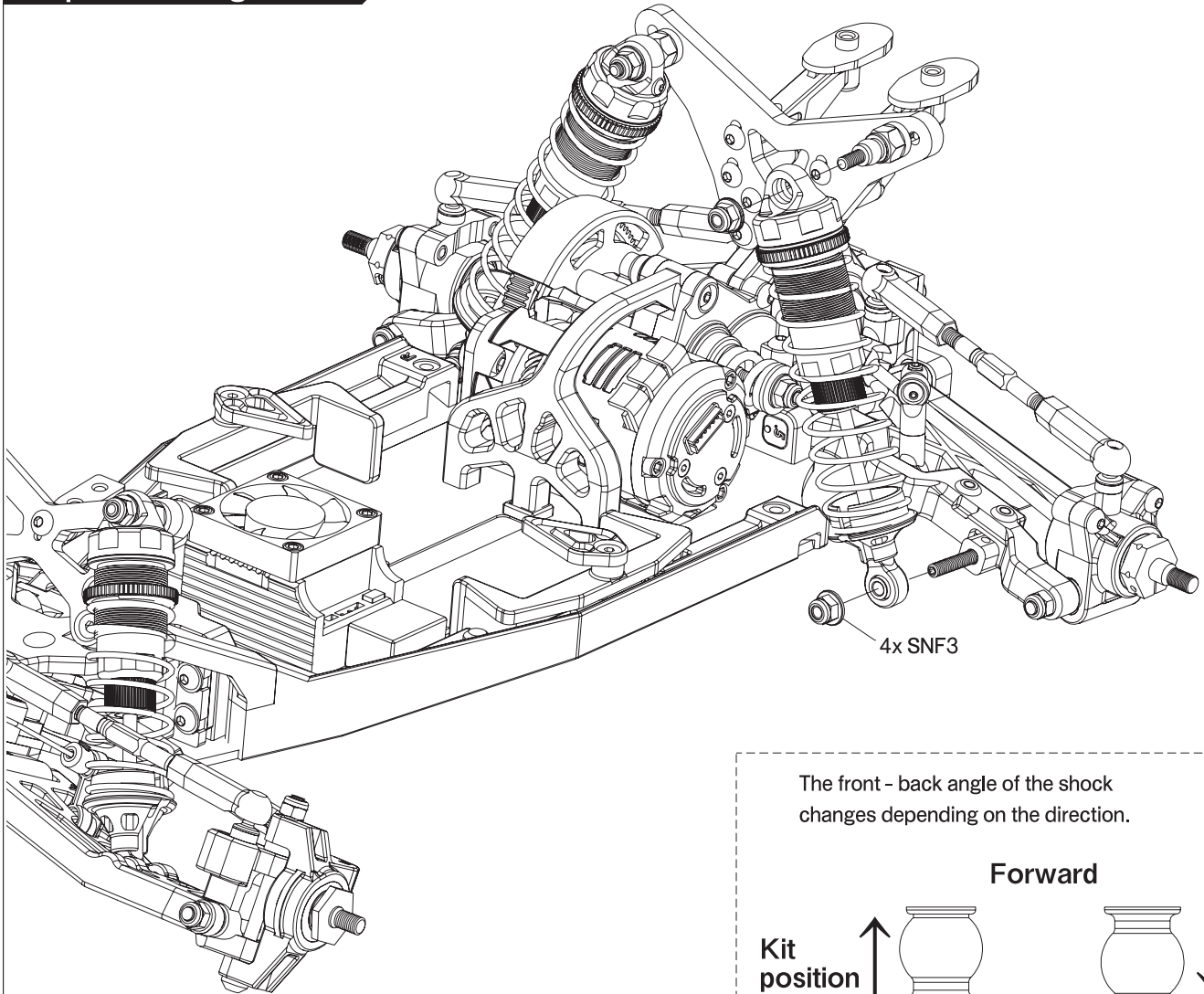

The front - back angle of the shock changes depending on the direction.

Forward

Kit position ↑

Backward ↓

Step 11-1

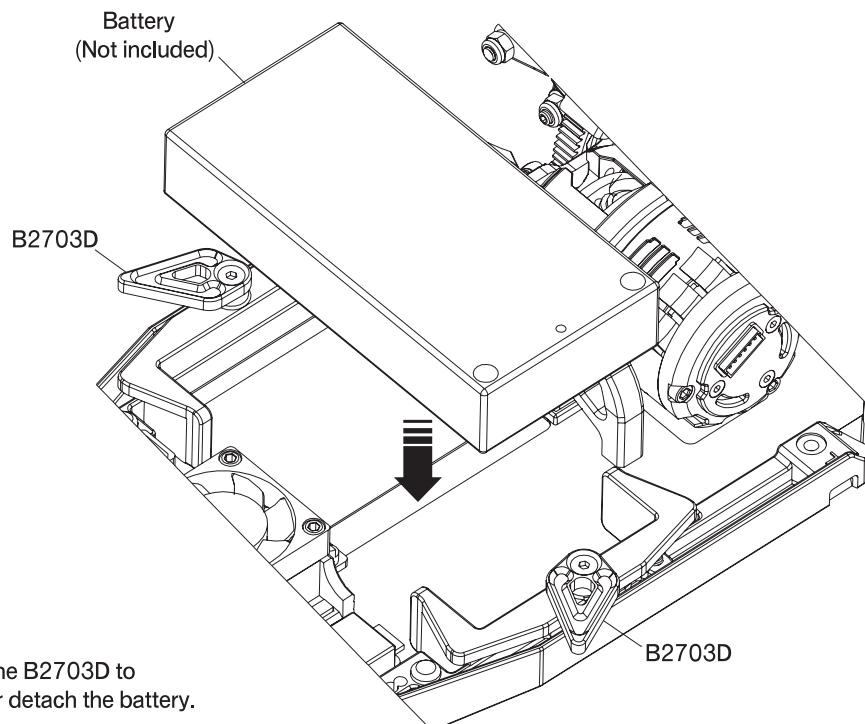

Rotate the B2703D to attach or detach the battery.

Step 12-1 / Bag i1

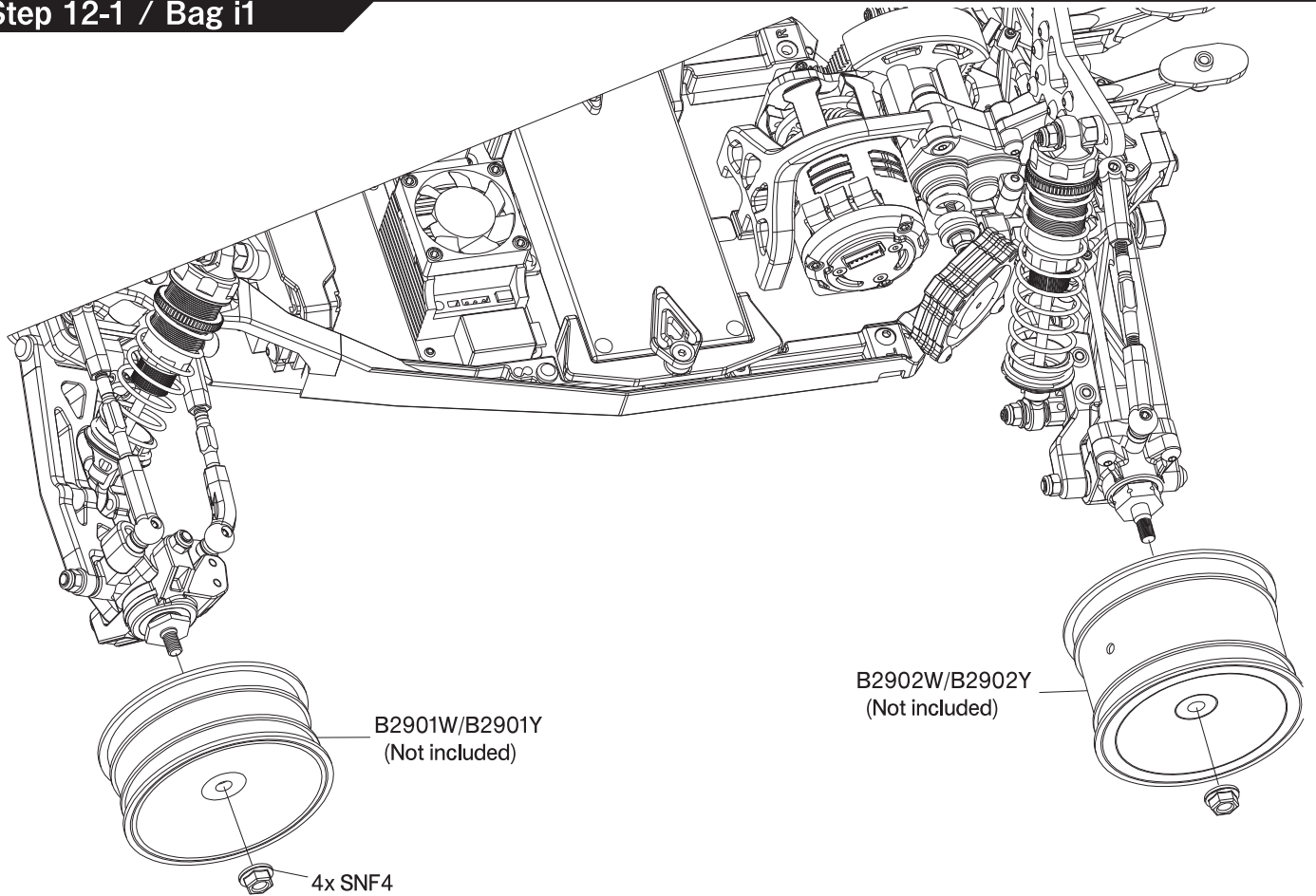

Step 13-1 / Bag K1

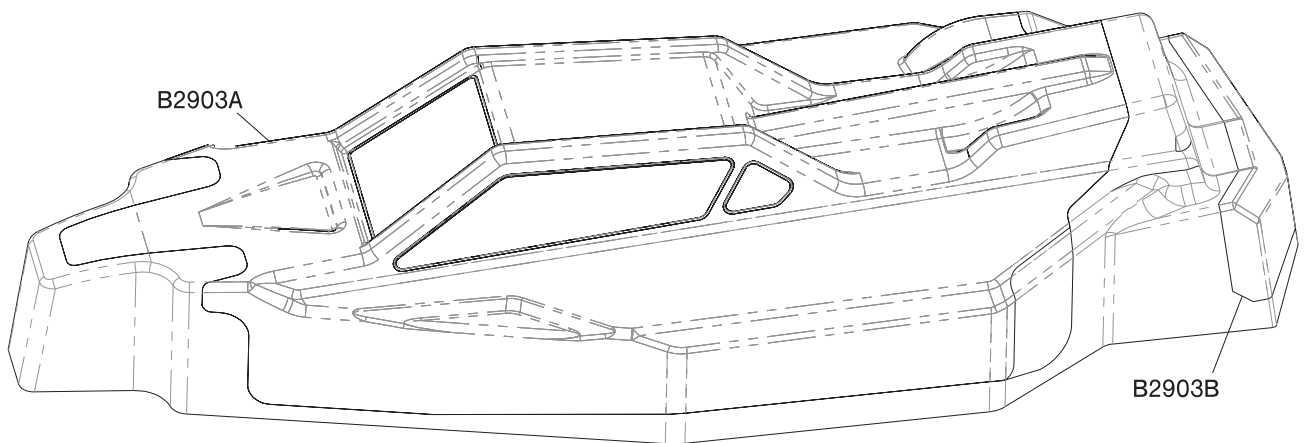

Cut the body and front wing
along the cut line.

Cut line A if motor fan is not used.
Cut line B when using a motor fan.

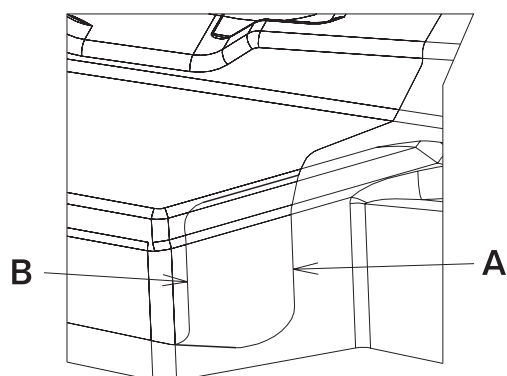

Step 12-2 / Bag K1

B2904

Cut B2904 along the cut line.

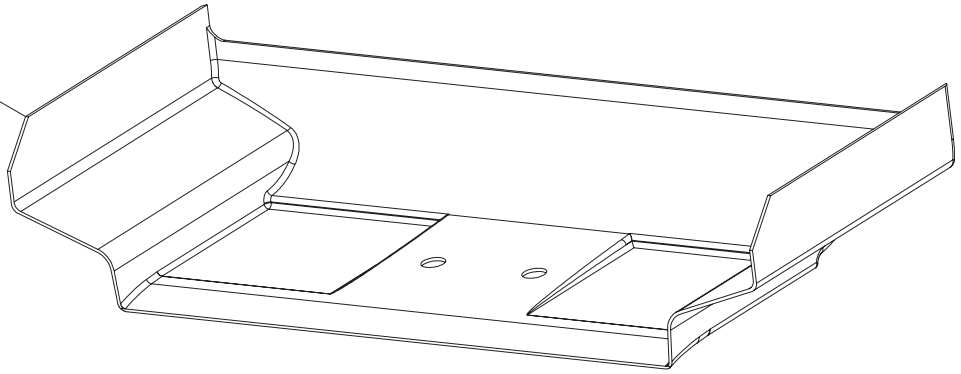

Step 13-1 / Bag i1, K1

Low mount front wing

2x SiG3x6

B2903B

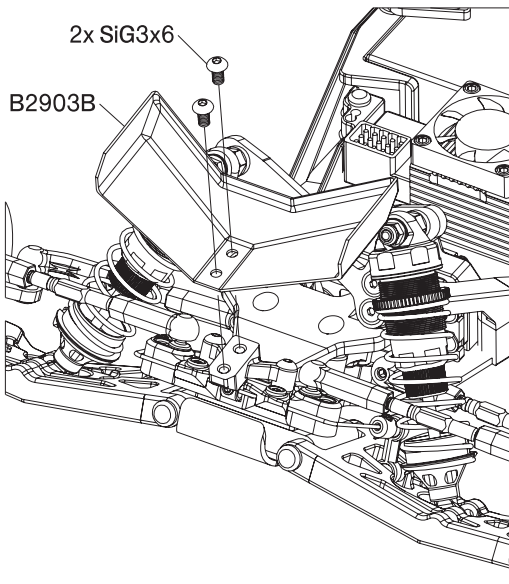

2x SJG3x10

2x B2803F

B2904

B2803E

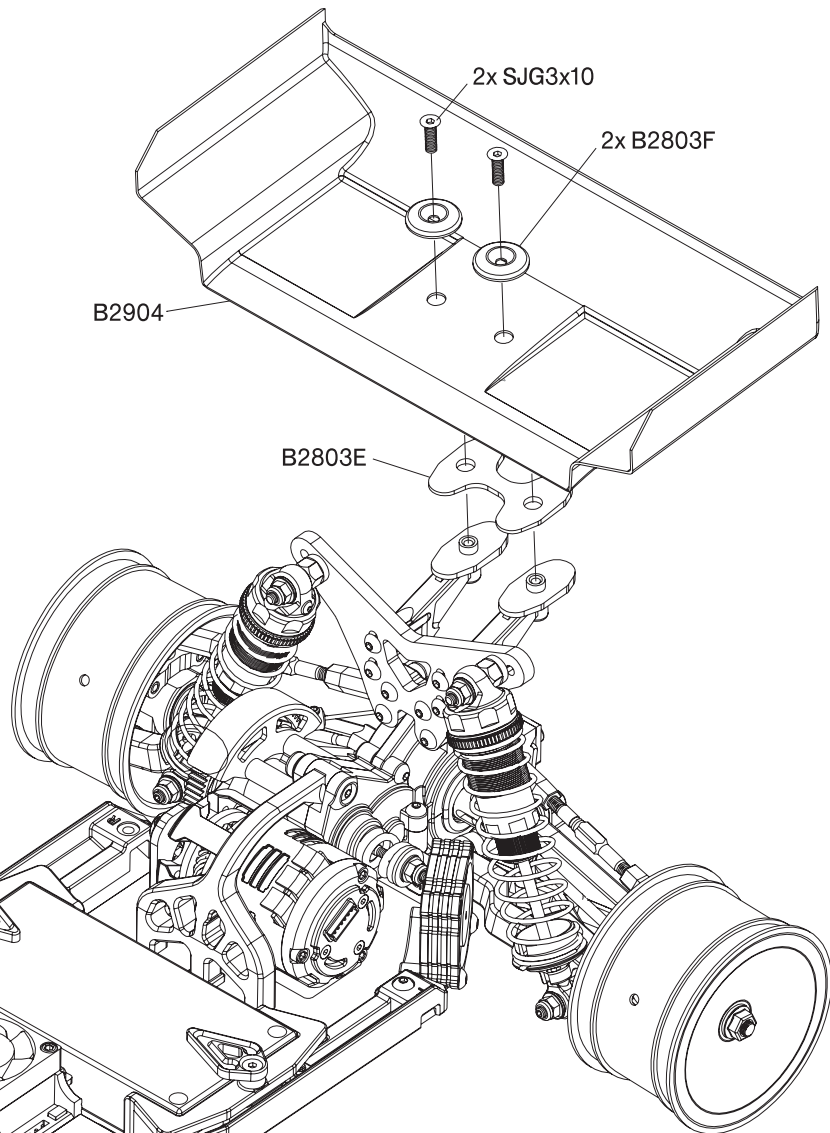

B2903B

2x SiG3x6

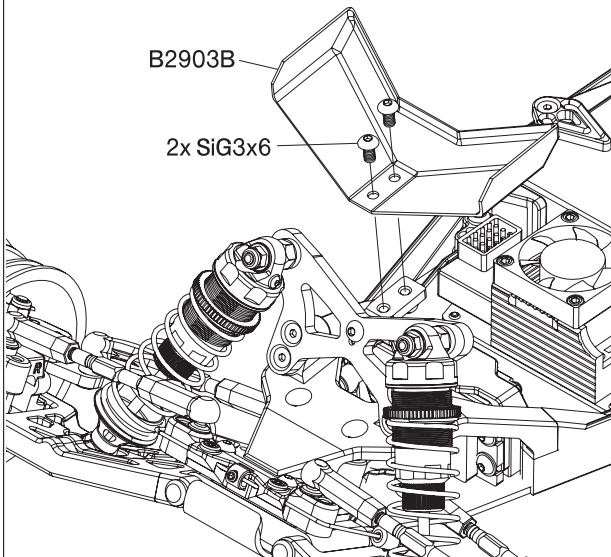

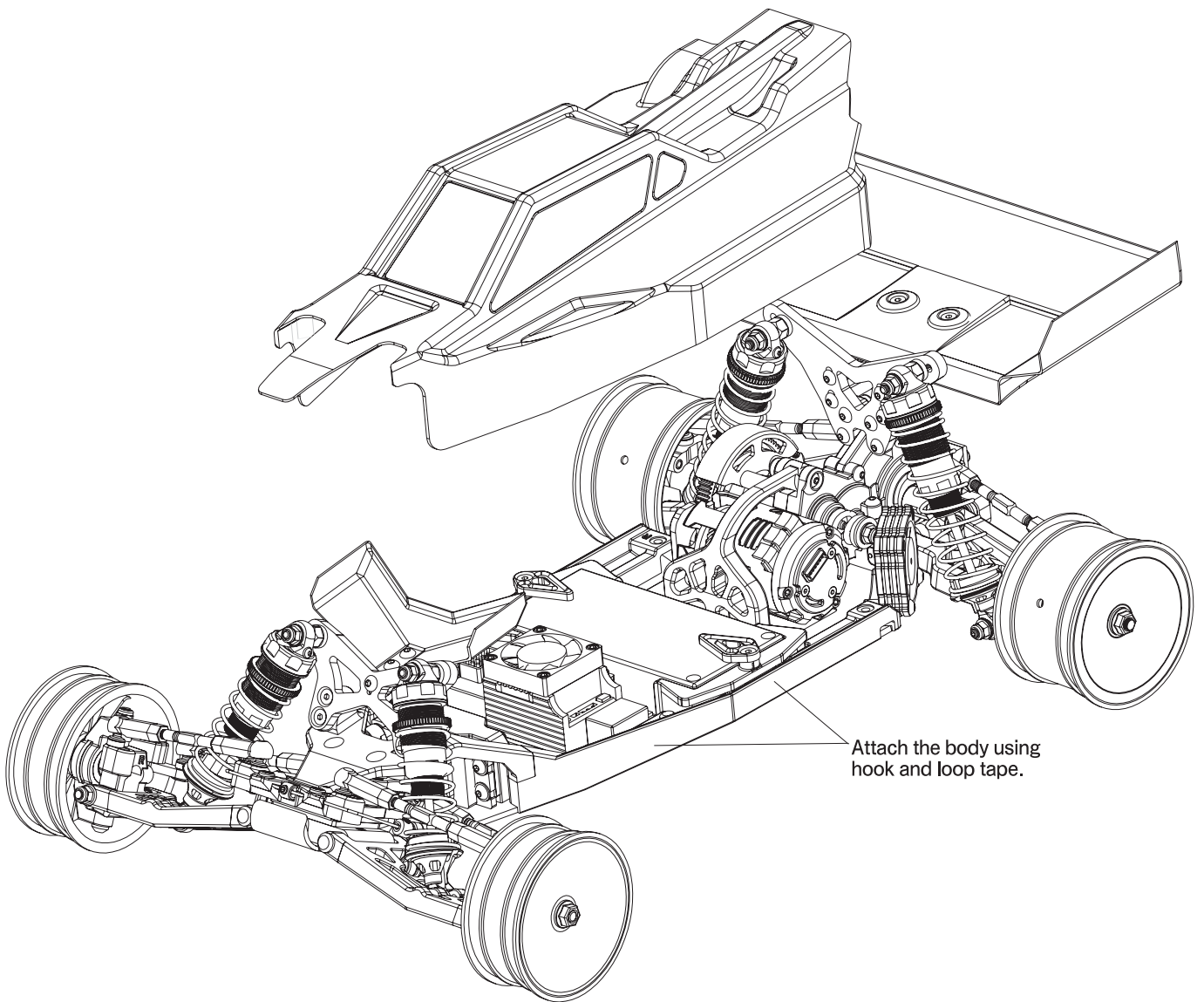

Attach the body using hook and loop tape.

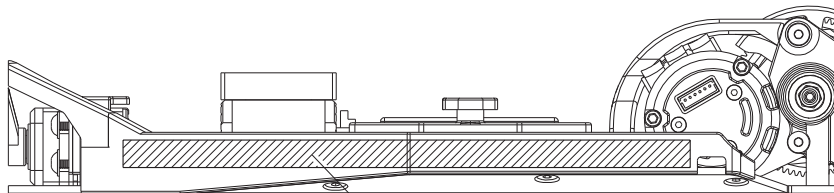

Cut the hook and loop tape in half and attach the hook side as shown. Attach the loop side to the painted body in the same way.

Before / After Operating

* it is very dangerous if you make a mistake in the order of on/off of the switch on transmitter and model.

Loss of control will result due to the interference of frequency.

Install the charged batteries on the model and connect the battery connectors.

Extend transmitter antenna and turn the power on. Then, turn on the switch of the model (ESC).

Raise the tires off the ground and check if the model is functioning properly.

Make sure the motor is not rotate at the neutral position of throttle.

Check the steering to operate the steering if the front tires move correctly.

Start operation after checking each part of the model moves properly in accordance with the operation of transmitter.

Always switch the model power (ESC) off first, and switch the transmitter power off after running.

Always disconnect/remove the batteries when the model is not in use.

Trouble Shooting

| PROBLEM | CAUSE | SOLUTION |
|--------------------------|---|---|
| Model doesn't move | Battery on model is not charged. The wiring is short-circuited. Motor failure. ESC failure. Assembly mistake in rotation part. | Charge it correctly. Insulating and repair the wiring. Repair or exchange the motor. Repair or exchange the ESC. Re-assemble it according to the instruction manual. |
| Model is hard to control | Weak transmitter and/or receiver batteries. Low reception from radio antennas. Servo linkage not adjusted properly. Assembly mistake in rotation part, wrong adjustment. | Recharge or replace batteries. Fully extend transmitter and receiver antennas. Re-assemble it according to the instruction manual. Re-assemble it according to the instruction manual. |

走行の準備、終了

*送信機および車体側スイッチのON/OFFの順番を間違えると大変危険です。電波の混信によって車体が暴走する恐れがあります。

十分に充電されたバッテリーを車体に取り付け、コネクターをつなぎます。

送信機のスイッチをONにします。次に車体（スピードコントローラー）のスイッチをONにします。

車体を台等に載せ、タイヤを浮かせた状態にします。

スロットルのニュートラルの状態でもーターが回転しないことを確認します。

ステアリングが正常に動くか確認します。

送信機の操作をおこない、車体各部の動きが正常であることを確認した後、走行を開始してください。

走行終了後、車体（スピードコントローラー）のスイッチをOFFにします。

その後に送信機のスイッチをOFFにします。

走行後は必ず車体からバッテリーをはずしておいてください。

トラブルシューティング

| 車の状態 | 考えられる原因 | 直し方 |
|--------------|--|---|
| 車が全く動かない。 | 走行用バッテリーが充電されていない。 配線がショートしている。 モーターが故障している。 スピードコントローラーが故障している。 回転部の組立て間違い。 | 走行用バッテリーを充電する。 ショート箇所を絶縁等、修理する。 モーターを修理もしくは交換する。 スピードコントローラーを修理もしくは交換する。 取扱説明書通りに組立て直す。 |
| 車が思いどおり動かない。 | 送信機、走行用バッテリーが減っている。 電波の送受信状態が良くない。 サーボリンクエージの調整不足。 回転部の組立て間違い、調整不足。 | バッテリーを交換もしくは充電する。 送受信機のアンテナを完全に伸ばす。 取扱説明書通りに組立て直す。 取扱説明書通りに組立て直す。 |

SAFETY PRECAUTIONS ※Please read carefully before assembling and operating your model.

- This product is high performance radio control model car. Follow the rules and enjoy your drive.
- To enjoy this model to its fullest, prepare other necessary equipments and convenient tools for assembly before.
- Improper usage of batteries for radio control model car may not only damages the electronics of the car and/or radio, but can cause excess heat build-up and possibly a fire, resulting in serious accidents. Be sure to operate the battery safely.

In order to avoid accidents and personal injury, adhere to following instructions:

Handling of radio control car

This model car can exceed very high speed, and cannot be stopped quickly. Operate your model only on designated areas, race tracks and other spacious areas. Also, be sure to operate the model car safely to avoid serious personal injury, property damage, and unforeseen accidents."

Before assembling

- Before you begin, read the instruction manual thoroughly.
- Read the instruction manual attached to Transmitter, ESC, or Motor, and understand how to use beforehand.
- Keep out of the reach of children.
- All tools require careful handling to avoid injury.
- Painting must be done only in a well-ventilated area.
- Feel free to contact us if there is an uncertain point about our product.

Check before operations

- Be sure to tight screws, nuts etc. securely and install all parts.
- Make sure whether the movable part works smoothly.
- Check the transmitter and/or receiver batteries charged fully.
- Check and do not use the same radio frequency with someone at the same time.
- Switch "ON" the Transmitter and then ESC, check the steering servo and ESC to work properly. With weak batteries, transmission and reception of the radio fall off. Models may become out of control under such condition, which may cause serious accidents.
- Stop the model car immediately when the electric wave is interrupted and it is not possible to control.

Cautions during operations

- Always run your car with the body shell mounted.
- Do not put fingers or any objects inside rotating and moving parts (Tire, Shaft, Gear).
- Stop the model car and check the problem immediately when it is behaving strangely or a strange sound is heard.
- Do NOT operate in -----
 1. Crowded place
 2. Near Children
 3. Near residential districts, schools, and hospitals
 4. Near roads and railroads
 5. Indoors and in limited space
 6. Nighttime and early morning
 7. Place where running of radio control model car is prohibited

Cautions after operations

- Always switch off the Speed controller and then Transmitter. The car might be loss of control when it makes a mistake in order.
- Do not touch the Motor, ESC, battery because it might be very hot after use.
- Always disconnect/remove the batteries when the model is not in use. Failure to do so may cause damage to the batteries from excessive discharge and leaking.
- Do care after running to keep performance, and to notice the damage and the wear to avoid further trouble.
- Do not store the model car in hot or humid conditions, or in direct sunlight.

Handling of battery

- Be careful of handling of the battery.
- Properly connect plugs firmly.
- Never reverse connection nor disassemble batteries.
- When using rechargeable batteries, carefully read and follow the instructions supplied with the battery and charger unit.

MUGEN SEIKI CO., LTD.

1395 Takane-cho, Funabashi, Chiba
274-0817, Japan

E-mail: support@mugenseiki.com
www.mugenseiki.co.jp
www.mugenseiki.com

MUGEN SEIKI RACING LTD.

20525 Crescent Bay Drive
Lake Forest, CA 92630, USA

E-mail: support@mugenracing.com
www.mugenracing.com

MSE MUGEN SEIKI Europe Vertriebs GmbH

Auf'm Wasserkamp 3,
D-45881 Gelsenkirchen, Germany

E-mail: info@mugen.eu
www.mugen.eu