

Name: _____ Date: _____ Event: _____
 City: _____ State: _____ Track: _____

Track Conditions: Indoor Tight Smooth Hard Packed Blue Groove Wet Grass Low Bite High Bite
 Outdoor Open Rough Loose/Loamy Dry Dusty Astro Turf Med Bite Other _____

Front Suspension

Ride Height: _____
 Camber: _____
 Toe: _____
 Forward Front Pill: 1↓ .5↓ 0 .5↑ 1↑
 Rearward Front Pill: 1↓ .5↓ 0 .5↑ 1↑
 Steering Ackerman: Long Short
 Bump Steer: _____
 Camber Link: _____
 Sway Bar: _____
 Shock Type: Bladder Emulsion Oil: _____
 Piston: _____
 Spring: _____
 Shock Limiters: _____ Stroke: _____
 Overall Shock Length: _____
 Shock Location: _____
 Front Diff Fluid: _____
 Center Diff Fluid: _____

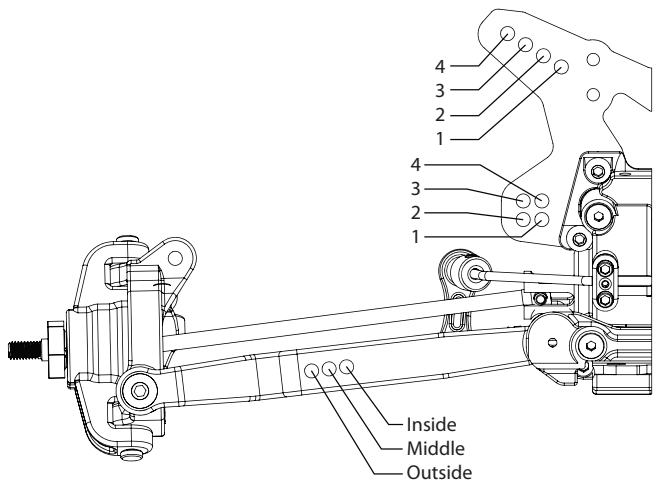

Notes: _____

Rear Suspension

Ride Height: _____
 Camber: _____
 Forward Rear Pill: 1↓ .5↓ 0 .5↑ 1↑
 Rearward Rear Pill: 1 In .5 In 0 .5 Out 1 Out
 Camber Link: _____
 Rear Hub Spacing: _____
 Sway Bar: _____
 Shock Type: Bladder Emulsion Oil: _____
 Piston: _____
 Spring: _____
 Shock Limiters: _____ Stroke: _____
 Overall Shock Length: _____
 Shock Location: _____
 Rear Diff Fluid: _____
 Battery Position: _____

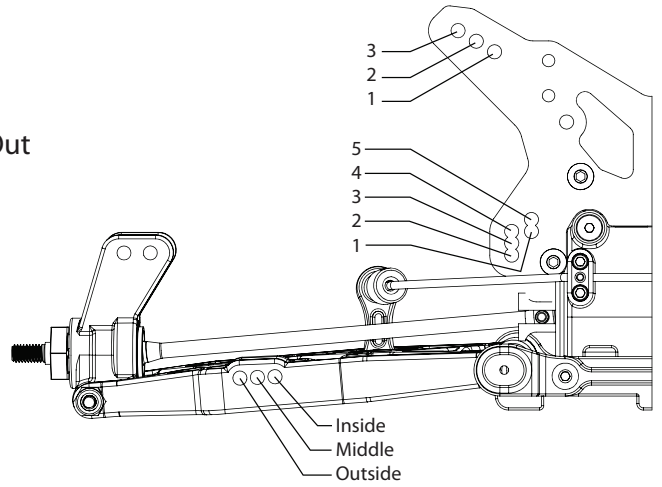

Notes: _____

Electronics

Radio: _____ Timing Advance: _____
 Servo: _____ Throttle/Brake Expo: _____
 ESC: _____ Servo Expo: _____
 Initial Brake: _____ Throttle/Brake EPA: _____
 Drag Brake: _____ Motor: _____
 Throttle Profile: _____ Pinion: _____ Spur: _____
 Battery: _____

Weight Placement (Mark with "X")

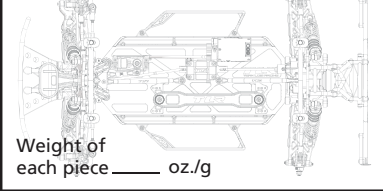

Tires Front: _____ Compound _____ Insert _____ Additive _____
 Rear: _____ Compound _____ Insert _____ Additive _____
 Notes: _____

Weight of each piece _____ oz./g