

HORIZON[®]
H O B B Y

Eflite[®]
ADVANCING ELECTRIC FLIGHT



CONVERGENCE[™] VTOL

Instruction Manual
Bedienungsanleitung
Manuel d'utilisation
Manuale di Istruzioni

Bind-N-Fly[®] **Plug-N-Play[®]**
BASIC

NOTICE

All instructions, warranties and other collateral documents are subject to change at the sole discretion of Horizon Hobby, LLC. For up-to-date product literature, visit www.horizonhobby.com and click on the support tab for this product.

Meaning of Special Language:

The following terms are used throughout the product literature to indicate various levels of potential harm when operating this product:

NOTICE: Procedures, which if not properly followed, create a possibility of physical property damage AND little or no possibility of injury.

CAUTION: Procedures, which if not properly followed, create the probability of physical property damage AND a possibility of serious injury.

WARNING: Procedures, which if not properly followed, create the probability of property damage, collateral damage, and serious injury OR create a high probability of superficial injury.

 **WARNING:** Read the ENTIRE instruction manual to become familiar with the features of the product before operating. Failure to operate the product correctly can result in damage to the product, personal property and cause serious injury.

This is a sophisticated hobby product. It must be operated with caution and common sense and requires some basic mechanical ability. Failure to operate this Product in a safe and responsible manner could result in injury or damage to the product or other property. This product is not intended for use by children without direct adult supervision. Do not use with incompatible components or alter this product in any way outside of the instructions provided by Horizon Hobby, LLC. This manual contains instructions for safety, operation and maintenance. It is essential to read and follow all the instructions and warnings in the manual, prior to assembly, setup or use, in order to operate correctly and avoid damage or serious injury.

14+

AGE RECOMMENDATION:
Not for children under 14 years.
This is not a toy.



WARNING AGAINST COUNTERFEIT PRODUCTS: If you ever need to replace your Spektrum receiver found in a Horizon Hobby product, always purchase from Horizon Hobby, LLC or a Horizon Hobby authorized dealer to ensure authentic high-quality Spektrum product. Horizon Hobby, LLC disclaims all support and warranty with regards, but not limited to, compatibility and performance of counterfeit products or products claiming compatibility with DSM or Spektrum technology.

Safety Precautions and Warnings

As the user of this product, you are solely responsible for operating in a manner that does not endanger yourself and others or result in damage to the product or the property of others.

- Always keep a safe distance in all directions around your model to avoid collisions or injury. This model is controlled by a radio signal subject to interference from many sources outside your control. Interference can cause momentary loss of control.
- Always operate your model in open spaces away from full-size vehicles, traffic and people.
- Always carefully follow the directions and warnings for this and any optional support equipment (chargers, rechargeable battery packs, etc.).
- Always keep all chemicals, small parts and anything electrical out of the reach of children.
- Always avoid water exposure to all equipment not specifically designed and protected for this purpose. Moisture causes damage to electronics.

- Never place any portion of the model in your mouth as it could cause serious injury or even death.
- Never operate your model with low transmitter batteries.
- Always keep aircraft in sight and under control.
- Always use fully charged batteries.
- Always keep transmitter powered on while aircraft is powered.
- Always remove batteries before disassembly.
- Always keep moving parts clean.
- Always keep parts dry.
- Always let parts cool after use before touching.
- Always remove batteries after use.
- Always ensure failsafe is properly set before flying.
- Never operate aircraft with damaged wiring.
- Never touch moving parts.

Box Contents

Quick Start Information

Transmitter Setup	Set up your transmitter using the transmitter setup table
Center of Gravity (CG)	154-168 mm from the front of the FPV camera mount, as shown in the <i>Center of Gravity</i> section (CG must be set with the motor nacelles in the multirotor flight, upright position)
Flight Timer Setting	6 minutes

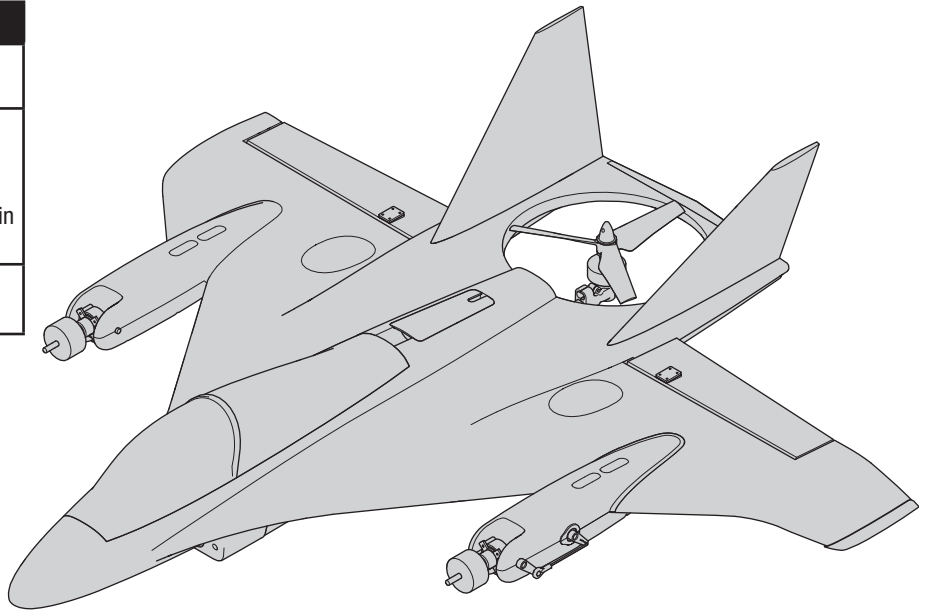
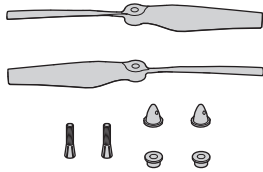

Specifications

		BNF BASIC	PNP PLUG-N-PLAY
	Motors: (2) 2210-1450Kv Main Motors (1) 2730 - 1550Kv Tail Motor	Installed	Installed
	ESC: (3) 20 AMP Brushless ESCs	Installed	Installed
	(2) 9 g Elevon Servos (2) 9 g, Metal Gear Nacelle Servos	Installed	Installed
	Receiver: Spektrum Quad Race Serial Receiver w/Diversity (SPM4648)	Installed	Required
	Recommended Battery: 11.1V 3S 2200mAh 30C Li-Po (EFLB22003S30)	Required	Required
	Recommended Battery Charger: 3-cell Li-Po battery balancing charger	Required	Required
	Recommended Transmitter: Full-Range 6 channel 2.4GHz with Spektrum™ DSMX® technology	Required	Required

Table of Contents

Preflight.....	4
Transmitter Setup	4
Model Assembly	4
Transmitter and Receiver Binding.....	5
Control Horn and Servo Arm Settings	5
Battery Installation and ESC Arming	6
Center of Gravity (CG)	7
Flight Control Direction Test	7
Understanding the Primary Flight Controls	8
Flight Conditions	9
Flying Your Aircraft	10
In Flight Trimming	11
Post Flight.....	11
Motor Service.....	11
PNP Receiver Selection and Installation	12
FPV System Installation.....	13
Troubleshooting Guide	14
AMA National Model Aircraft Safety Code	15
Limited Warranty	16
Contact Information	17
FCC Information	17
IC Information.....	17
Compliance Information for the European Union.....	17
Exploded View / Explosionszeichnung / Vue Éclatée / Vista Esplosa	64
Replacement Parts • Ersatzteile • Pièces de rechange • Pezzi di ricambio	65
Optional Parts • Optionale Bauteile • Pièces optionnelles • Pezzi opzionali	65

To receive product updates, special offers and more, register your product at www.e-fliterc.com

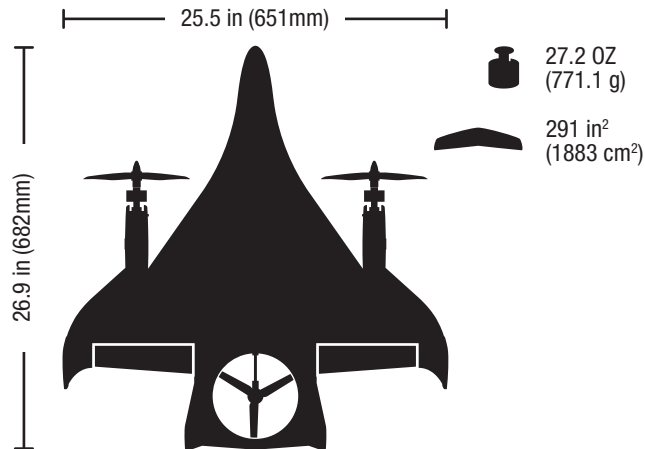

As of this printing, you are required to register with the FAA if you own this product.

For up-to-date information on how to register with the FAA, please visit <https://registermyuas.faa.gov/>. For additional assistance on regulations and guidance on UAS usage, visit knowbeforeyoufly.org/.

Preflight

1. Remove and inspect contents.
2. Read this instruction manual thoroughly.
3. Charge the flight battery.
4. Setup Transmitter using transmitter setup chart.
5. Fully assemble the airplane.
6. Install the flight battery in the aircraft (once it has been fully charged).
7. Check the Center of Gravity (CG).
8. Bind the aircraft to your transmitter.

9. Make sure linkages move freely.
10. Perform the Control Direction Test with the transmitter.
11. Perform the stability system control direction test with the aircraft.
12. Adjust flight controls and transmitter.
13. Perform a radio system Range Test.
14. Find a safe open area to fly.
15. Plan flight for flying field conditions.

Transmitter Setup

The Convergence™ aircraft requires a transmitter with a minimum of 6 channels and 2 open two-position switches.

Flight Modes are controlled by channel 5.

The transition from vertical flight to forward flight is controlled by channel 6.

IMPORTANT: After you set up your model, always rebind the transmitter and receiver to set the desired failsafe positions.

Expo

After the first few flights, you may adjust expo up or down in your transmitter to better suit your flying style.

Computerized Transmitter Setup

(DXe*, DX6e, DX6, DX7 (Gen2), DX8 (Gen2), DX9, DX18 and DX20)

Start all transmitter programming with a blank ACRO model (perform a model reset), then name the model.

Set Expo values to	Elevator 25%
	Aileron 25%
	Rudder 0%
Set Servo Travel to	100%
DX6 (Gen2) DX7 (Gen2) DX8 (Gen2) DX9 DX18 DX20	1. Go to the SYSTEM SETUP
	2. Set MODEL TYPE: AIRPLANE
	3. Set AICRAFT TYPE: WING: NORMAL
	4. Set CHANNEL ASSIGN: (NEXT) CHANNEL INPUT CONFIG: GEAR: A AUX1: H

* To download the DXe Convergence™ setup, visit www.spektrumrc.com.

Model Assembly

Install the Vertical Fins

Install the vertical fins on the fuselage using two screws per side as shown.

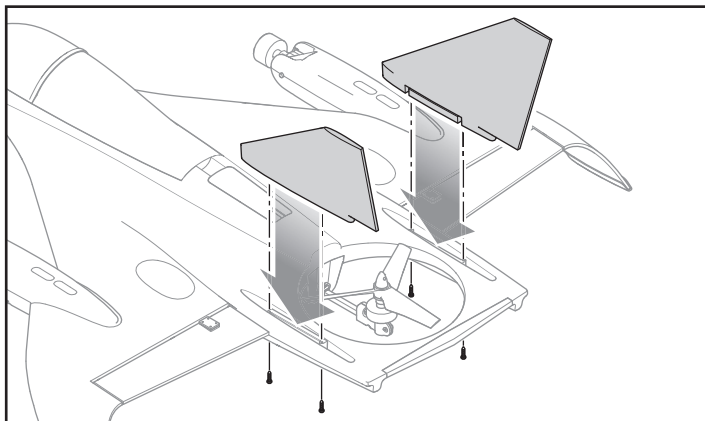

Install the Main Propellers

The main propellers are labelled near the hub with an "R" and an "L" to show on which side they should be installed.

1. Find the propeller collets, backplates and nuts.
2. Place a collet over the right side motor shaft as shown.
3. Slide a backplate over the collet.
4. Place the propeller marked "R" over the collet, with the "R" facing away from the motor.
5. Install the propeller nut on the collet. Use a small screwdriver or hex wrench through the hole in the propeller nut to tighten. Do not overtighten the propeller nut as damage to the propeller, nut or collet may occur.
6. Repeat steps 1-5 for the left motor using the propeller marked "L".

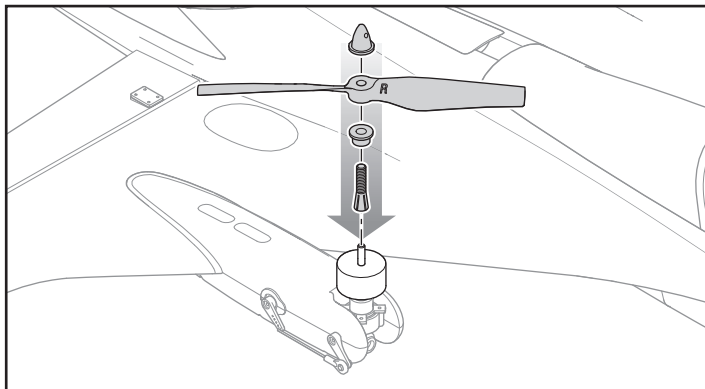

Transmitter and Receiver Binding

This product requires an approved Spektrum™ DSM2®/DSMX® compatible transmitter. Visit www.bindnfly.com for a complete list of approved transmitters.

IMPORTANT: Before binding a transmitter, read the *Transmitter Setup* section to ensure that your transmitter is properly programmed for this aircraft.

If you encounter problems, follow the binding instructions and refer to the transmitter troubleshooting guide for other instructions. If needed, contact the appropriate Horizon Product Support office.

Motor Nacelle Positions

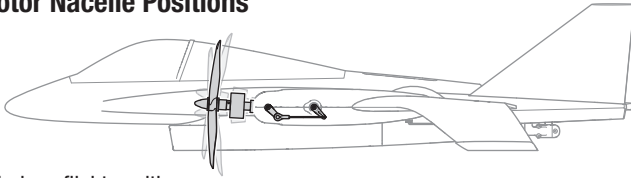

Airplane flight position

Motor position may vary slightly depending on aircraft orientation and current flight mode.

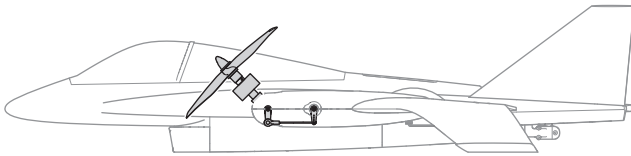

Transition position

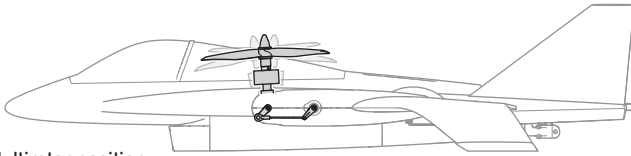

Multirotor position

Motor position may vary slightly depending on aircraft orientation and current flight mode.

Binding Procedure



CAUTION: When using a Futaba® transmitter with a Spektrum DSM2 module, you must reverse the throttle channel and rebind. Refer to your Spektrum module manual for binding and failsafe instructions. Refer to your Futaba transmitter manual for instructions on reversing the throttle channel.

1. Make sure the transmitter is powered off.
2. Center all trims and move the throttle stick to the lowest position.
3. Place the aircraft on a level surface. Connect the flight battery to the flight controller. The flight controller will produce a series of tones indicating it is initializing. The motor nacelles will rotate to the mid-transition point and then to the near-upright, multirotor position.

IMPORTANT: The flight controller will not power the receiver on until the flight controller is fully initialized, indicated by the motor nacelles rotating to the multirotor position.

When the nacelles reach the multirotor position the receiver is ready to bind.
4. Take 3 steps away from the aircraft/receiver and then power ON the transmitter in bind mode. Refer to your transmitter's manual for specific binding instructions.
5. The receiver is bound to the transmitter when the LED on the receiver glows solid orange.

IMPORTANT: The flight controller will not arm the ESCs if the throttle is not in the lowest position and the throttle trim at or below center.
6. Power cycle the aircraft by unplugging and plugging in the flight battery to the flight controller. The flight controller will initialize again.

IMPORTANT: The aircraft will not respond to transmitter input until the receiver is power cycled.

IMPORTANT: After binding the receiver and transmitter for the first time, the transmitter must be powered on first, before the aircraft. Failure to power on the transmitter first will cause the receiver to automatically go into bind mode and requiring the transmitter and receiver to have to be re-bound.

Control Horn and Servo Arm Settings

The table to the right shows the factory settings for the control horns and servo arms. Fly the aircraft at factory settings before making any changes to the elevon linkages.



CAUTION: Do not change the length of the motor nacelle control linkages or their positions on the servo horns. Changing the linkages could cause a loss of control and possibly a crash. Crash damage is not covered under warranty.

	Control Horns	Servo Arms
Elevons		
Motor Nacelles		

Battery Installation and ESC Arming

Battery Selection

We recommend the E-flite® 2200mAh 11.1V 3S 30C Li-Po battery (EFLB22003S30). Refer to the *Optional Parts* list for other recommended batteries. If using a battery other than those listed, the battery should be within the range of capacity, dimensions and weight of the E-flite Li-Po battery packs to fit in the fuselage.

1. Lower the throttle and throttle trim to the lowest settings. Set the flight attitude switch to multirotor flight. Power on the transmitter and wait approximately 5 seconds.
2. Carefully lift the back of the battery hatch and pull back to remove it.
3. For added security, apply the loop side (soft side) of the optional hook and loop tape to the bottom of your battery and the hook side to the battery tray.
4. Install the fully charged battery in the battery compartment as shown. Secure using the hook and loop strap.
5. Connect the battery to the flight controller.
6. Keep the aircraft upright, immobile and away from wind or the system will not initialize.
 - The motor nacelles will rotate to the middle position briefly and then to the upright, multirotor flight position, indicating the flight controller has initialized and the ESCs are armed.

CAUTION: Always keep hands away from the propeller. When armed, the motor will turn the propeller in response to any throttle movement.

7. Reinstall the battery hatch.
8. Refer to the Center of Gravity section to ensure the model balances at the recommended CG.

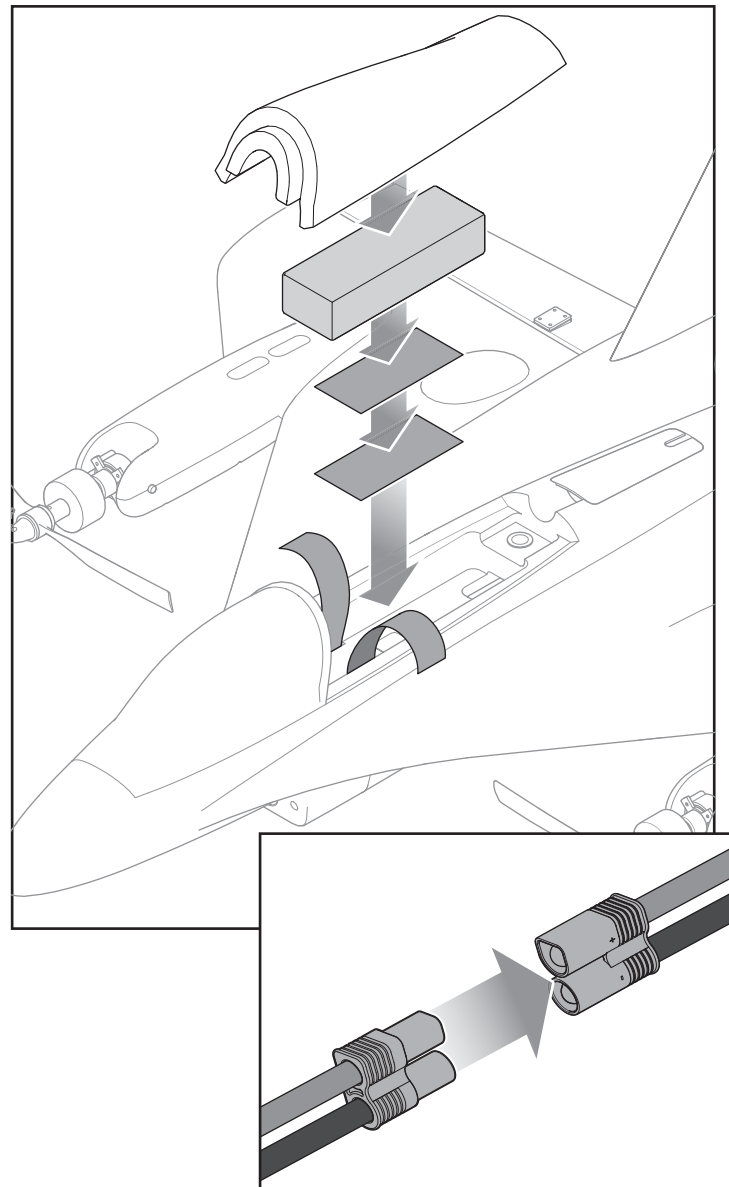

Center of Gravity (CG)

The CG location is within 154-168mm, measured from the bottom corner of the front of the FPV camera mount as shown in the illustration.

CAUTION: The main motor nacelles must be in the upright, multicopter flight position when checking the center of gravity. Failure to do so will give an incorrect center of gravity and may cause a crash. Crash damage is not covered under warranty.

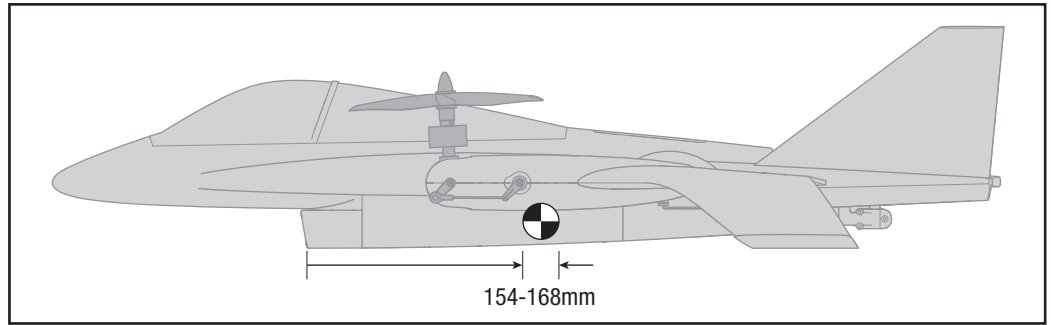

Flight Control Direction Test

This test ensures that the flight control system is functioning properly. Assemble the aircraft and bind your transmitter to the receiver before performing this test.

CAUTION: Keep all body parts, hair and loose clothing away from a moving propeller, as these items could become entangled.

Set the transmitter switches to airplane flight, stability mode. Move the entire aircraft as shown in the table and ensure the control surfaces move in the direction indicated. If the control surfaces do not respond as shown, do not fly the aircraft. Contact Horizon Product Support.

Once the flight control system is active, control surfaces may move rapidly. This is normal.

Aircraft Movement	Elevon Reaction

Understanding the Primary Flight Controls

The Convergence™ aircraft is capable of both forward, airplane flight and vertical, multirotor flight. It is important to understand how the primary flight controls function and how the aircraft reacts in both flight modes. Take a few minutes to familiarize yourself with the controls prior to attempting your first flight.

Multicopter Flight

Throttle

Left side view

Left side view

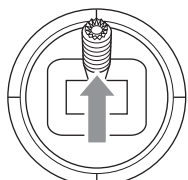

Throttle up

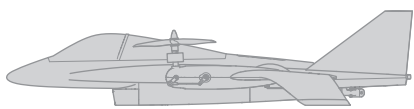

Climb

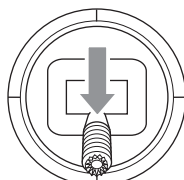

Throttle down

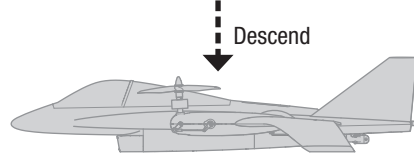

Descend

Elevator

Left side view

Left side view

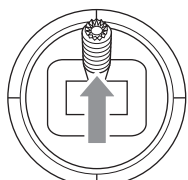

Elevator down

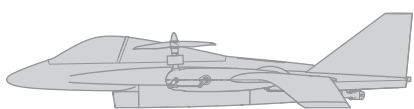

Forward

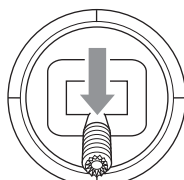

Elevator up

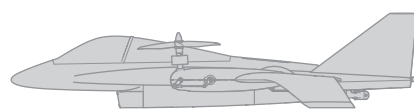

Backward

Aileron

Rear view

Rear view

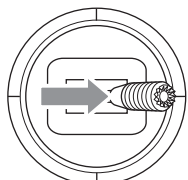

Aileron right

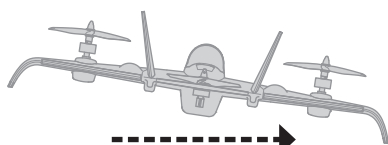

Right

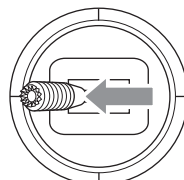

Aileron left

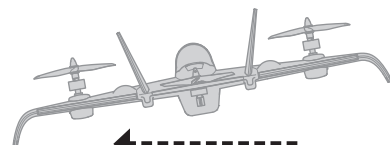

Left

Rudder

Top view

Top view

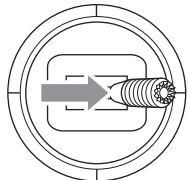

Rudder right

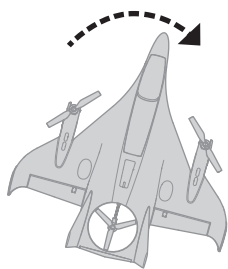

Yaw right

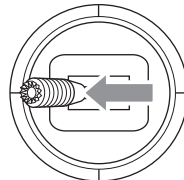

Rudder left

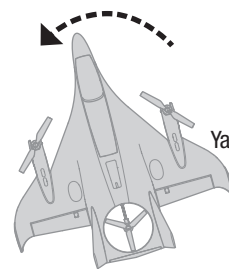

Yaw left

Airplane Flight

Throttle

Left side view

Left side view

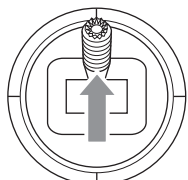

Throttle up

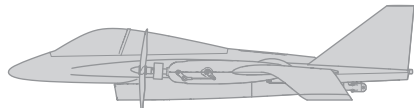

Faster

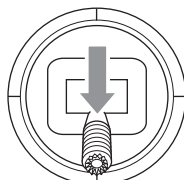

Throttle down

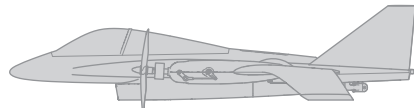

Slower

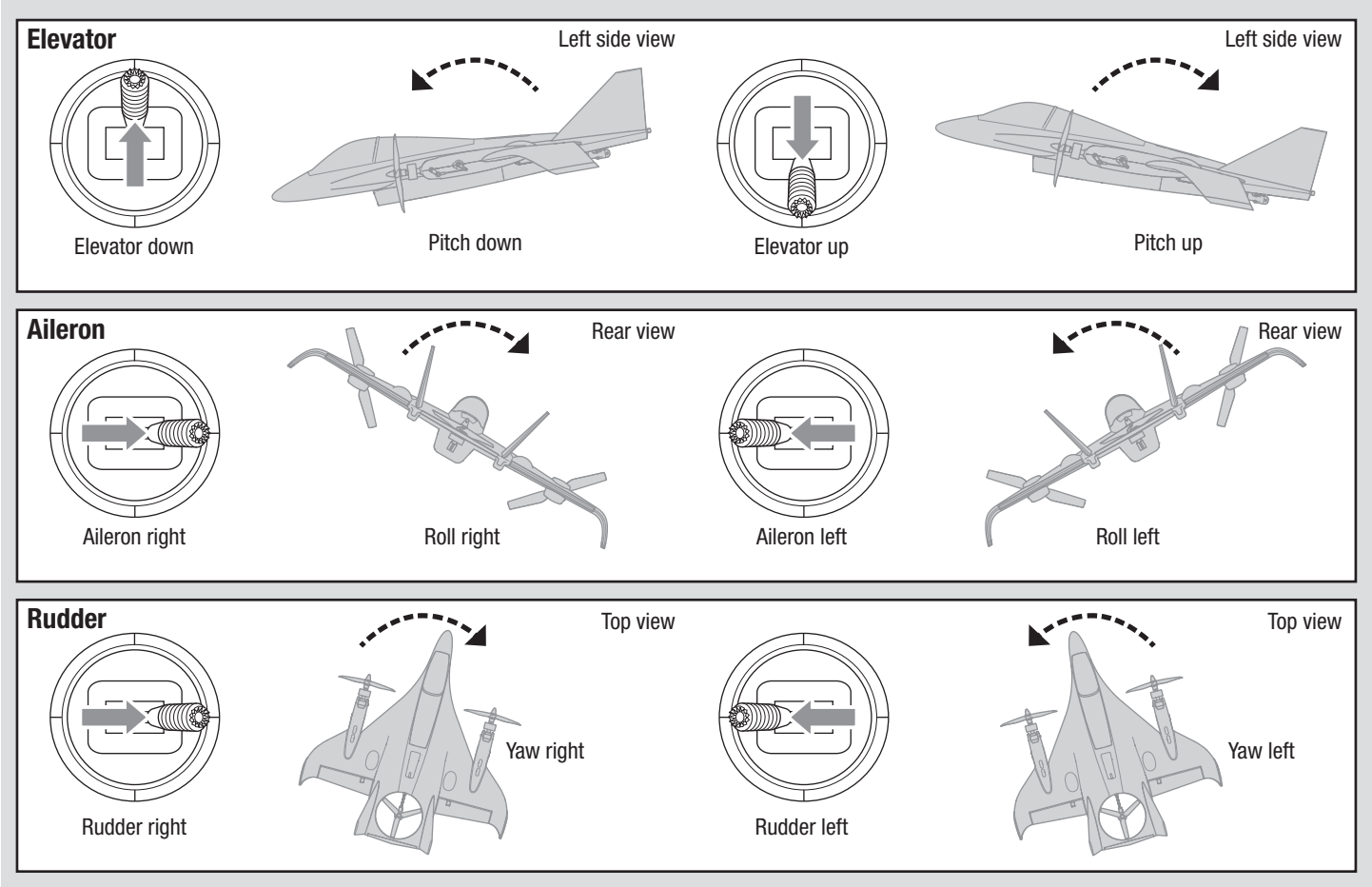

Flight Conditions

Stability and Acro Flight Modes are available in both airplane flight and multirotor flight. The basic function of each mode is the same regardless of what realm of flight is active.

Stability Mode

Stability Mode limits the bank and pitch angle of the aircraft. The aircraft will self-level if you release the transmitter sticks.

Acro Mode

Acro Mode removes the bank angle limits and will not self-level the aircraft if you release the transmitter sticks. Acro Mode is intended for experienced pilots who are comfortable flying the aircraft in any orientation.

The following table gives the switch positions and a brief description of the possible flight conditions available.

	Multirotor Flight (Switch H, Position 1)	Airplane Flight (Switch H, Position 0)
Stability Mode (Switch A, Position 0)	<ul style="list-style-type: none"> • Limited bank angle • Very little pitch change • Forward and backward flight is achieved through angling of the main motor nacelles • Self-levelling • Elevons inactive • Tail motor runs • Use this condition for all takeoffs and landings 	<ul style="list-style-type: none"> • Limited bank angle • Self-levelling • Elevons active • Tail motor does not run • Do not attempt to land or takeoff in this condition
Acro Mode (Switch A, Position 1)	<ul style="list-style-type: none"> • Unlimited bank and pitch angles • Does not self-level • Elevons inactive • Tail motor runs • Do not attempt to land or takeoff in this condition if you are an inexperienced pilot 	<ul style="list-style-type: none"> • Unlimited bank and pitch angles • Does not self-level • Elevons active • Tail motor does not run • Do not attempt to land or takeoff in this condition

Flying Your Aircraft

Consult local laws and ordinances before choosing a flying location.

Range Check your Radio System

Before you fly, range check the radio system. Refer to your specific transmitter instruction manual for range test information.

Just Before Flight

Once the flight control system is active, you will normally see the control surfaces react to aircraft movement.

For your first flights with the recommended battery pack (EFLB22003S30), set your transmitter timer or a stopwatch to 6 minutes.

NOTICE: Never fly the aircraft without first setting and activating a timer.

After 6 minutes, land the aircraft. Adjust your timer for longer or shorter flights depending on your preference and battery usage.

Takeoff

NOTICE: All takeoffs and landings must be done in multirotor flight. Attempting to land in airplane flight will damage the motors and nacelles possibly causing a crash. Crash damage is not covered under warranty.

Place the aircraft on a flat, level surface with the tail facing you. Set your transmitter to multirotor flight and stability mode.

Tip: Stability mode is highly recommended for the first few takeoffs and landings, until you become familiar with how the aircraft reacts to control inputs.

Check that the motor nacelles are in the fully upright position before applying throttle. Gradually increase the throttle until the model is approximately 2 ft. (600mm) off the ground. Avoid forcing the aircraft into the air.

Hovering and Multirotor Flight

Making small corrections on the transmitter, try to hold the aircraft in one spot. If flying in calm winds, the model should require almost no corrective inputs.

After moving the aileron/elevator stick and returning it to center the model should level itself. The model may continue to move due to inertia. Move the stick in the opposite direction to stop the movement.

After you become comfortable hovering, you can progress into flying the model to different locations, keeping the tail pointed towards you at all times. You can also ascend and descend using the throttle stick.

Once you are comfortable with these maneuvers, you can attempt flying with the tail in different orientations. It is important to keep in mind that the flight control inputs will rotate with the aircraft, so always try to picture the control inputs relative to the nose of the aircraft. For example, forward will always drop the nose of the aircraft, causing the aircraft to move forward.

NOTICE: Do not attempt to fly backwards at a high rate of speed. While the aircraft is capable of flying backwards while in multirotor mode, the aircraft becomes more unstable as backward speed increases due to airflow over the fixed wings.

Transitioning In Flight

To transition to airplane flight from multirotor flight, change the flight attitude switch on your transmitter to the airplane flight position. The throttle will increase slightly and the motor nacelles will rotate forward in three stages to the airplane flight position. The elevons become active. It is normal to have some slight oscillations in pitch as the aircraft transitions into airplane flight. While in airplane flight mode the main motors use differential thrust to provide yaw control and the tail motor does not run.

To transition to multirotor flight from airplane flight, reduce the airspeed, change the flight attitude switch on your transmitter to the multirotor flight position and stability mode for landing. The throttle will increase slightly and the motor nacelles will rotate to the vertical position. The tail motor will power on and the elevons will go to neutral. While in multirotor flight the elevons do not move. All pitch, roll and yaw control is accomplished by differential thrust and angling of the motors.

NOTICE: Do not transition to multirotor flight at low throttle or lower the throttle immediately after transitioning to multirotor flight. Doing so will cause a rapid loss of altitude and possibly a crash.

Airplane Flight

Fly the aircraft and trim it for level flight per the *Trimming Your Aircraft* section. The Convergence flies in a very similar manner to any other fixed-wing aircraft. It is capable of a wide range of aerobatic maneuvers including loops, rolls and spins. Additionally, the differential thrust of the motors allows for unique spinning and tumbling maneuvers.

Landing

NOTICE: All takeoffs and landings must be done in multirotor mode.

Attempting to land in airplane mode will damage the motors and rotation mechanisms possibly causing a crash. Crash damage is not covered under warranty.

Transition the aircraft into multirotor flight and bring it into a low hover. Slowly lower the throttle to descend to a soft landing.

NOTICE: If a crash is imminent, reduce the throttle and trim fully. Failure to do so could result in extra damage to the airframe, as well as damage to the ESCs, motors and motor nacelles.

NOTICE: Crash damage is not covered under warranty.

NOTICE: When you are finished flying, never leave the aircraft in direct sunlight or in a hot, enclosed area such as a car. Doing so can damage the aircraft.

Low Voltage Cutoff (LVC)

The average flight time with a mixture of multirotor and airplane flight using the recommended flight battery is approximately 6 minutes.

The flight controller protects the flight battery from over-discharge using Low Voltage Cutoff (LVC). When the flight battery is drained to LVC the flight controller will automatically transition the motors into stability mode, multirotor flight. The remaining battery will last less than a minute, so land the aircraft as soon as possible.

There will be no visual indication if you are flying in stability mode, multirotor flight when the battery reaches LVC. In this flight condition the motors will slowly lose power until the ESCs cutoff. If you begin to notice the motors dropping in power, land immediately and re-charge the flight battery.

After landing disconnect and remove the Li-Po battery from the aircraft to prevent trickle discharge. Charge your Li-Po battery to about half capacity before storage. During storage, make sure the battery charge does not fall below 3V per cell. LVC does not prevent the battery from over-discharge during storage.

NOTICE: Repeated flying to LVC may damage the battery.

Tip: Monitor your aircraft battery's voltage before and after flying by using a Li-Po Cell Voltage Checker (EFLA111, sold separately).

Repairs

Thanks to the Z-Foam™ material in this aircraft, repairs to the foam can be made using virtually any adhesive (hot glue, regular CA, epoxy, etc). When parts are not repairable, see the Replacement Parts List for ordering by item number. For a listing of all replacement and optional parts, refer to the list at the end of this manual.

NOTICE: Use of CA accelerant on your aircraft can damage paint. DO NOT handle the aircraft until accelerant fully dries.

In Flight Trimming

Familiarize yourself with the *Flying Your Aircraft* section prior to trimming your aircraft. Trimming should be done in calm wind conditions and with a fully charged transmitter and flight battery.

1. During your first Airplane Flight, trim the aircraft for level flight at approximately 3/4 throttle.
2. Make small trim adjustments with your transmitter's trim switches to straighten the aircraft's flight path.
3. When the aircraft maintains straight and level flight, land the aircraft in multi-rotor mode.
4. Set the flight mode back to airplane mode. Take note of the neutral position of the control surfaces.

5. Adjust the control linkages mechanically to compensate for the amount of trim entered.
6. Re-center the trims on the transmitter. **The transmitter trims should always be centered for best flight performance.**
7. Fly the aircraft again to check the changes made.
8. Repeat the trimming process until the aircraft will maintain reasonable straight and level forward flight.

When the initial trimming process is done, the aircraft should not require large amounts of trimming on subsequent flights. If large amounts of trim are needed to hold straight and level flight on later flights, land the aircraft and check the control surfaces for damage or binding.

Post Flight

1. Disconnect the flight battery from the flight controller (Required for Safety and battery life).

2. Power OFF the transmitter.

3. Remove the flight battery from the aircraft.

4. Recharge the flight battery.

5. Repair or replace all damaged parts.

6. Store the flight battery apart from the aircraft and monitor the battery charge.

7. Make note of the flight conditions and flight plan results, planning for future flights.

Motor Service

CAUTION: Always disconnect the flight battery before performing motor service.

Main Motor Removal

1. Pull the base of the rubber motor wire boot out of the nacelle slot.
2. Disconnect the motor wires from the ESC.
3. Remove the spinner nut from the collet shaft.
4. Remove the propeller, collet backplate and collet from the motor shaft.
5. Loosen both set screws on the motor mount.
6. Pull the motor from the motor mount.

Assembly is the reverse of the removal process.

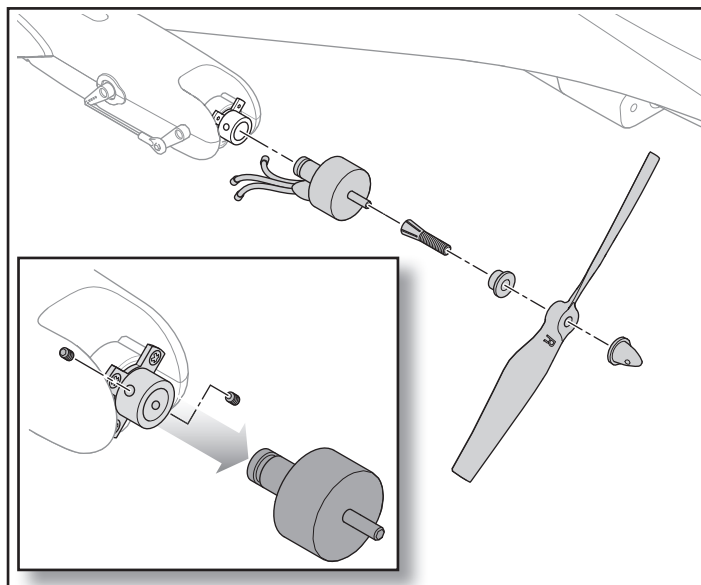

Tail Motor Removal

1. Slide the wire clip fully to the rear of the tailboom.
2. Disconnect the tail motor wires from the ESC.
3. Remove the spinner nut from the collet shaft.
4. Remove the propeller, collet backplate and collet from the motor shaft.
5. Remove 3 screws from the tail motor mount and remove the left half of the motor mount.
6. Remove the tail motor from the mount and carefully remove the motor wires from the plastic wire clip.

Assembly is the reverse of the removal process.

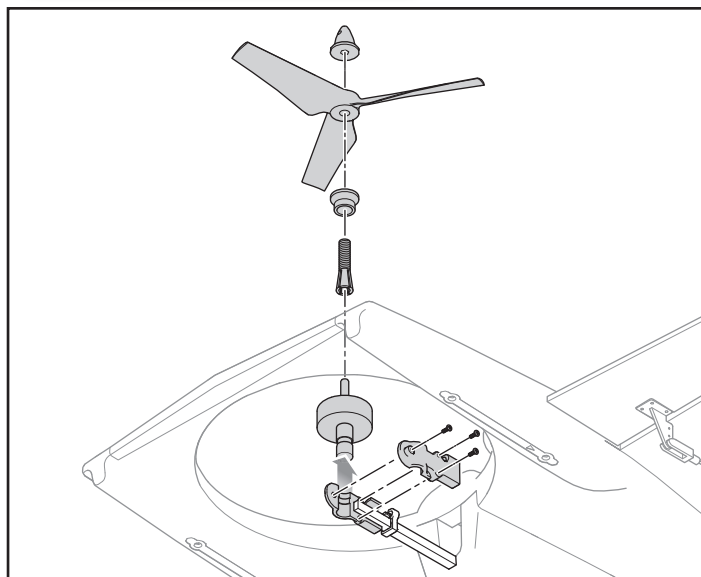

PNP Receiver Selection and Installation

The Convergence aircraft is capable of using either the Spektrum™ DSMX® serial receiver (SPM4648), included in the BNF aircraft, or a standard 6-channel full range (sport) receiver. Refer to your receiver manual for correct installation and operation instructions.

Installation of a DSMX serial receiver

1. Remove the bottom cover from the fuselage.
2. Mount the receiver to the fuselage as shown using double-sided servo tape or hook and loop material.
3. Attach the serial receiver lead to the receiver and to the flight control board as shown below.
4. Replace the bottom fuselage cover.

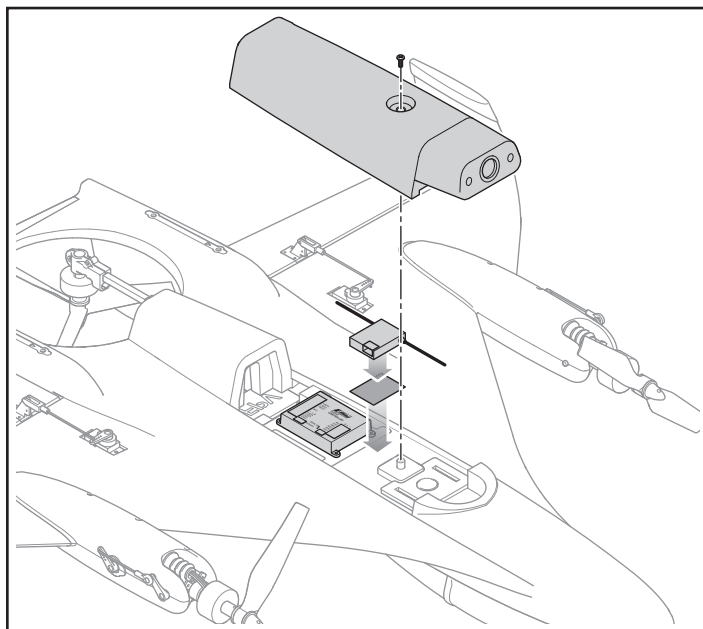

Flight Controller Connection

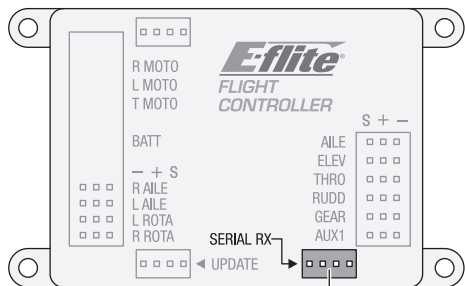

Serial Receiver port

Installation of a standard sport receiver

1. Remove the bottom cover from the fuselage.
2. Mount the receiver to the fuselage as shown using double-sided servo tape or hook and loop material.
3. Connect the individual channel jumpers from the flight controller to the corresponding channels on the receiver as shown below.
4. Replace the bottom fuselage cover.

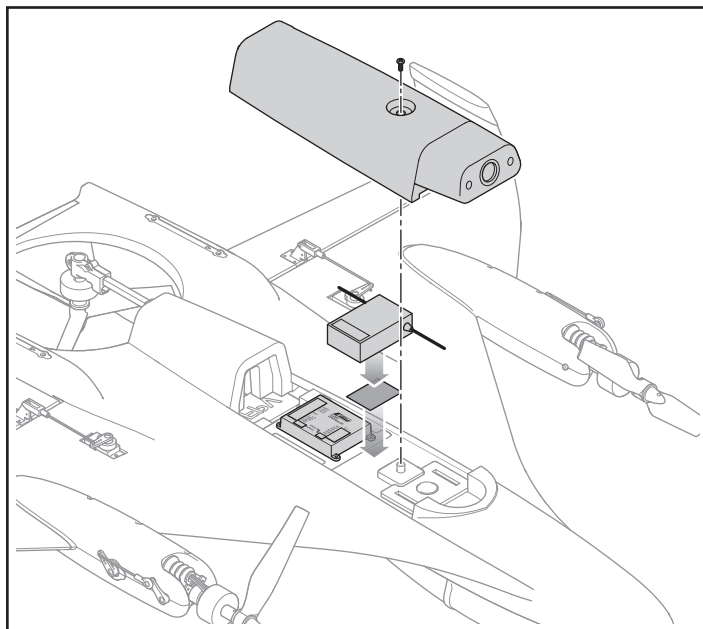

Flight Controller Connections

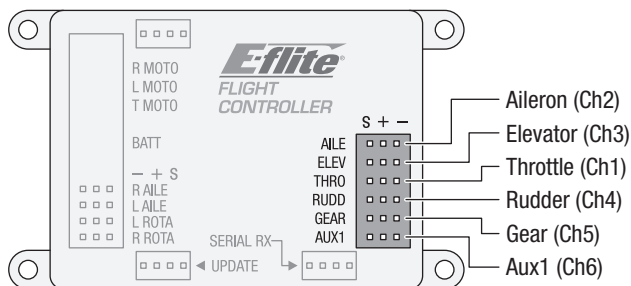

FPV System Installation

Items required for FPV installation:

- Camera, 650TVL CCD FPV Camera NTSC (SPMVC650)
- Video transmitter with the power output appropriate for your region
- Antenna, RHCP Omni Right Angle Connector (SPMVX5802)
- Power adapter, Air Telemetry Flight Pack Voltage Sensor: EC3 (SPMA9556)
- Spektrum 4.3 inch Video Monitor with Headset (SPMVM430C)

Installation of a video transmitter

1. Remove the video transmitter hatch by lifting at the front and pulling straight up.
2. Remove the battery hatch.
3. Connect the lead from the power adapter to the video transmitter harness.
 - a. Cut the micro connector from the power adapter leaving enough wire length from the adapter to reach from the battery compartment to the video transmitter.
 - b. Solder the wire from the power adapter to the video transmitter harness power and ground leads, noting proper polarity. The red wire from the adapter connects to the "gnd" port from the harness. Be sure to properly insulate the wire connections using heat shrink tubing.
4. Connect the power adapter EC3 plug to the power lead from the flight controller.
5. Remove the bottom fuselage cover.
6. Thread the video camera connector from the FPV compartment, through the fuselage and to the front of the bottom compartment.
7. Attach the video transmitter antenna to the video transmitter.
8. Mount the video transmitter to the mounting plate provided in the fuselage using either double sided foam tape or self-adhesive hook and loop material. The video transmitter must be oriented so the antenna exits at the rear of the compartment, through the slot in the hatch.
9. Replace the video transmitter hatch by gently pushing in on the sides and pressing the hatch straight down into the fuselage.

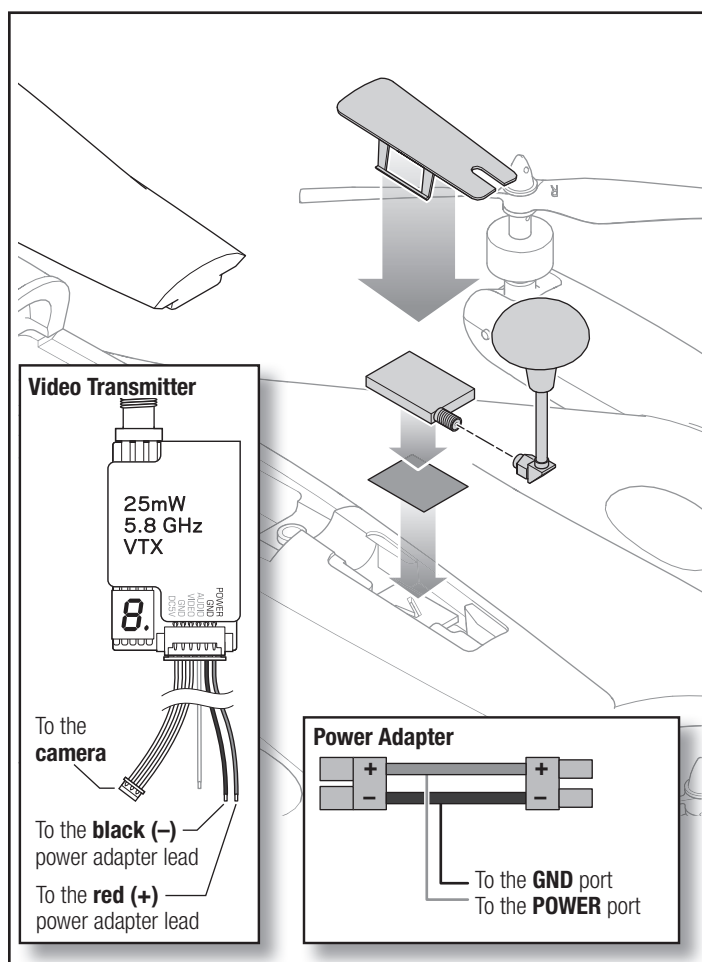

Installation of an FPV camera:

1. Remove the bottom cover from the fuselage if not already removed.
2. Connect the video camera lead to the video camera.
3. Align the camera lens with the opening in the camera mount and slide the camera body into the camera mount as shown. The pins on the sides of the camera body align with the holes in the sides of the mount and will snap into the holes when the camera is fully seated in the mount.
4. Replace the bottom cover to the fuselage.

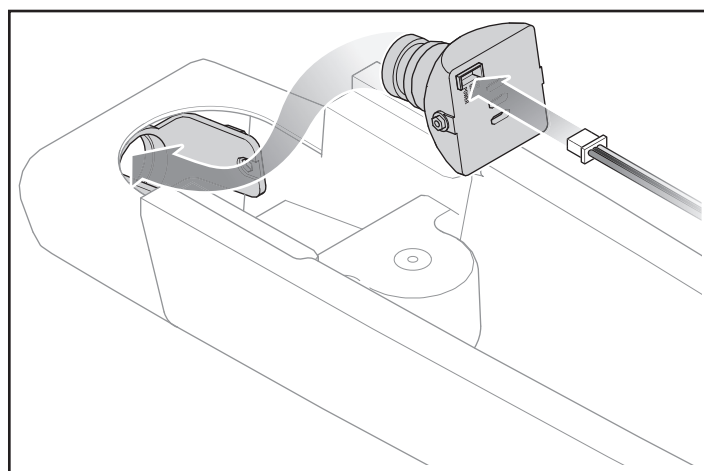

Troubleshooting Guide

Problem	Possible Cause	Solution
Aircraft will not respond to throttle but responds to other controls	Throttle not at idle and/or throttle trim too high	Reset controls with throttle stick and throttle trim at lowest setting
	Throttle servo travel is lower than 100%	Make sure throttle servo travel is 100% or greater
	Throttle channel is reversed	Reverse throttle channel on transmitter
	Motors disconnected from ESCs	Make sure motors are connected to the ESCs
Extra propeller noise or extra vibration	Damaged propeller and spinner, collet or motor	Replace damaged parts
	Propeller is out of balance	Balance or replace propeller
	Prop nut is too loose	Tighten the prop nut
Reduced flight time or aircraft underpowered	Flight battery charge is low	Completely recharge flight battery
	Propeller installed backwards	Install propeller with numbers facing forward
	Flight battery damaged	Replace flight battery and follow flight battery instructions
	Flight conditions may be too cold	Make sure battery is warm before use
	Battery capacity too low for flight conditions	Replace battery or use a larger capacity battery
Aircraft will not Bind (during binding) to transmitter	Transmitter too near aircraft during binding process	Move powered transmitter a few feet from aircraft, disconnect and reconnect flight battery to aircraft
	Aircraft or transmitter is too close to large metal object, wireless source or another transmitter	Move aircraft and transmitter to another location and attempt binding again
	Flight battery/transmitter battery charge is too low	Replace/recharge batteries
	Bind switch or button not held long enough during bind process	Power off transmitter and repeat bind process. Hold transmitter bind button or switch until receiver is bound
Aircraft will not connect (after binding) to transmitter	Transmitter too near aircraft during connecting process	Move powered transmitter a few feet from aircraft, disconnect and reconnect flight battery to aircraft
	Aircraft or transmitter is too close to large metal object, wireless source or another transmitter	Move aircraft and transmitter to another location and attempt connecting again
	Aircraft bound to different model memory (ModelMatch™ radios only)	Select correct model memory on transmitter
	Flight battery/Transmitter battery charge is too low	Replace/recharge batteries
	Transmitter may have been bound to a different aircraft using different DSM protocol	Bind aircraft to transmitter
Control surface does not move	Control surface, control horn, linkage or servo damage	Replace or repair damaged parts and adjust controls
	Wire damaged or connections loose	Do a check of wires and connections, connect or replace as needed
	Transmitter is not bound correctly or the incorrect airplanes was selected	Re-bind or select correct airplanes in transmitter
	Flight battery charge is low	Fully recharge flight battery
	Flight controller is damaged	Replace the flight controller
	Transmitter is set to multirotor flight	Set the transmitter switch to airplane flight
Controls reversed	Transmitter settings are reversed	Perform the Control Direction Test and adjust the controls on transmitter appropriately
Oscillation	Damaged propeller or spinner nut	Replace propeller or spinner nut
	Imbalanced propeller	Balance the propeller
	Motor vibration	Replace parts or correctly align all parts and tighten fasteners as needed
	Loose flight controller	Align and secure the flight controller in fuselage
	Loose aircraft controls	Tighten or otherwise secure parts (servo, arm, linkage, horn and control surface)
	Worn parts	Replace worn parts (especially propeller, spinner nut or servo)
	Irregular servo movement	Replace servo
Inconsistent flight performance	Trim is not at neutral	If you adjust trim more than 8 clicks, adjust the clevis to remove trim
	Sub-Trim is not at neutral	No Sub-Trim is allowed. Adjust the servo linkage
	Aircraft was not kept upright and immobile for 5 seconds after battery connection	With the throttle stick in lowest position, disconnect battery, then reconnect battery and keep the aircraft still for 5 seconds
Aircraft will not transition to or will not stay in airplane flight mode	Low battery. Low Voltage Cutoff is being triggered.	Recharge flight battery or replace battery that is no longer performing
Aircraft immediately flips or crashes on throttle up	Main propellers installed incorrectly	Install the propellers with the "R" propeller on the right side motor and the "L" propeller on the left side motor.

AMA National Model Aircraft Safety Code

Effective January 1, 2014

A. GENERAL

A model aircraft is a non-human-carrying aircraft capable of sustained flight in the atmosphere. It may not exceed limitations of this code and is intended exclusively for sport, recreation, education and/or competition. All model flights must be conducted in accordance with this safety code and any additional rules specific to the flying site.

1. Model aircraft will not be flown:
 - (a) In a careless or reckless manner.
 - (b) At a location where model aircraft activities are prohibited.
2. Model aircraft pilots will:
 - (a) Yield the right of way to all man carrying aircraft.
 - (b) See and avoid all aircraft and a spotter must be used when appropriate. (AMA Document #540-D.)
 - (c) Not fly higher than approximately 400 feet above ground level within three (3) miles of an airport, without notifying the airport operator.
 - (d) Not interfere with operations and traffic patterns at any airport, heliport or seaplane base except where there is a mixed use agreement.
 - (e) Not exceed a takeoff weight, including fuel, of 55 pounds unless in compliance with the AMA Large Model Aircraft program. (AMA Document 520-A.)
 - (f) Ensure the aircraft is identified with the name and address or AMA number of the owner on the inside or affixed to the outside of the model aircraft. (This does not apply to model aircraft flown indoors).
 - (g) Not operate aircraft with metal-blade propellers or with gaseous boosts except for helicopters operated under the provisions of AMA Document #555.
 - (h) Not operate model aircraft while under the influence of alcohol or while using any drug which could adversely affect the pilot's ability to safely control the model.
 - (i) Not operate model aircraft carrying pyrotechnic devices which explode or burn, or any device which propels a projectile or drops any object that creates a hazard to persons or property.

Exceptions:

 - Free Flight fuses or devices that burn producing smoke and are securely attached to the model aircraft during flight.
 - Rocket motors (using solid propellant) up to a G-series size may be used provided they remain attached to the model during flight. Model rockets may be flown in accordance with the National Model Rocketry Safety Code but may not be launched from model aircraft.
 - Officially designated AMA Air Show Teams (AST) are authorized to use devices and practices as defined within the Team AMA Program Document (AMA Document #718).
 - (j) Not operate a turbine-powered aircraft, unless in compliance with the AMA turbine regulations. (AMA Document #510-A).
3. Model aircraft will not be flown in AMA sanctioned events, air shows or model demonstrations unless:
 - (a) The aircraft, control system and pilot skills have successfully demonstrated all maneuvers intended or anticipated prior to the specific event.
 - (b) An inexperienced pilot is assisted by an experienced pilot.
4. When and where required by rule, helmets must be properly worn and fastened. They must be OSHA, DOT, ANSI, SNELL or NOCSAE approved or comply with comparable standards.

B. RADIO CONTROL

1. All pilots shall avoid flying directly over unprotected people, vessels, vehicles or structures and shall avoid endangerment of life and property of others.
2. A successful radio equipment ground-range check in accordance with manufacturer's recommendations will be completed before the first flight of a new or repaired model aircraft.
3. At all flying sites a safety line(s) must be established in front of which all flying takes place (AMA Document #706.)
 - (a) Only personnel associated with flying the model aircraft are allowed at or in front of the safety line.
 - (b) At air shows or demonstrations, a straight safety line must be established.
 - (c) An area away from the safety line must be maintained for spectators.
 - (d) Intentional flying behind the safety line is prohibited.
4. RC model aircraft must use the radio-control frequencies currently allowed by the Federal Communications Commission (FCC). Only individuals properly licensed by the FCC are authorized to operate equipment on Amateur Band frequencies.
5. RC model aircraft will not operate within three (3) miles of any pre-existing flying site without a frequency-management agreement (AMA Documents #922 and #923.)
6. With the exception of events flown under official AMA Competition Regulations, excluding takeoff and landing, no powered model may be flown outdoors closer than 25 feet to any individual, except for the pilot and the pilot's helper(s) located at the flight line.
7. Under no circumstances may a pilot or other person touch a model aircraft in flight while it is still under power, except to divert it from striking an individual.
8. RC night flying requires a lighting system providing the pilot with a clear view of the model's attitude and orientation at all times. Hand-held illumination systems are inadequate for night flying operations.
9. The pilot of a RC model aircraft shall:
 - (a) Maintain control during the entire flight, maintaining visual contact without enhancement other than by corrective lenses prescribed for the pilot.
 - (b) Fly using the assistance of a camera or First-Person View (FPV) only in accordance with the procedures outlined in AMA Document #550.
 - (c) Fly using the assistance of autopilot or stabilization system only in accordance with the procedures outlined in AMA Document #560.

Please see your local or regional modeling association's guidelines for proper, safe operation of your model aircraft.

Limited Warranty

What this Warranty Covers

Horizon Hobby, LLC, (Horizon) warrants to the original purchaser that the product purchased (the "Product") will be free from defects in materials and workmanship at the date of purchase.

What is Not Covered

This warranty is not transferable and does not cover (i) cosmetic damage, (ii) damage due to acts of God, accident, misuse, abuse, negligence, commercial use, or due to improper use, installation, operation or maintenance, (iii) modification of or to any part of the Product, (iv) attempted service by anyone other than a Horizon Hobby authorized service center, (v) Product not purchased from an authorized Horizon dealer, or (vi) Product not compliant with applicable technical regulations, or (vii) use that violates any applicable laws, rules, or regulations.

OTHER THAN THE EXPRESS WARRANTY ABOVE, HORIZON MAKES NO OTHER WARRANTY OR REPRESENTATION, AND HEREBY DISCLAIMS ANY AND ALL IMPLIED WARRANTIES, INCLUDING, WITHOUT LIMITATION, THE IMPLIED WARRANTIES OF NON-INFRINGEMENT, MERCHANTABILITY AND FITNESS FOR A PARTICULAR PURPOSE. THE PURCHASER ACKNOWLEDGES THAT THEY ALONE HAVE DETERMINED THAT THE PRODUCT WILL SUITABLY MEET THE REQUIREMENTS OF THE PURCHASER'S INTENDED USE.

Purchaser's Remedy

Horizon's sole obligation and purchaser's sole and exclusive remedy shall be that Horizon will, at its option, either (i) service, or (ii) replace, any Product determined by Horizon to be defective. Horizon reserves the right to inspect any and all Product(s) involved in a warranty claim. Service or replacement decisions are at the sole discretion of Horizon. Proof of purchase is required for all warranty claims. SERVICE OR REPLACEMENT AS PROVIDED UNDER THIS WARRANTY IS THE PURCHASER'S SOLE AND EXCLUSIVE REMEDY.

Limitation of Liability

HORIZON SHALL NOT BE LIABLE FOR SPECIAL, INDIRECT, INCIDENTAL OR CONSEQUENTIAL DAMAGES, LOSS OF PROFITS OR PRODUCTION OR COMMERCIAL LOSS IN ANY WAY, REGARDLESS OF WHETHER SUCH CLAIM IS BASED IN CONTRACT, WARRANTY, TORT, NEGLIGENCE, STRICT LIABILITY OR ANY OTHER THEORY OF LIABILITY, EVEN IF HORIZON HAS BEEN ADVISED OF THE POSSIBILITY OF SUCH DAMAGES. Further, in no event shall the liability of Horizon exceed the individual price of the Product on which liability is asserted. As Horizon has no control over use, setup, final assembly, modification or misuse, no liability shall be assumed nor accepted for any resulting damage or injury. By the act of use, setup or assembly, the user accepts all resulting liability. If you as the purchaser or user are not prepared to accept the liability associated with the use of the Product, purchaser is advised to return the Product immediately in new and unused condition to the place of purchase.

Law

These terms are governed by Illinois law (without regard to conflict of law principals). This warranty gives you specific legal rights, and you may also have other rights which vary from state to state. Horizon reserves the right to change or modify this warranty at any time without notice.

WARRANTY SERVICES

Questions, Assistance, and Services

Your local hobby store and/or place of purchase cannot provide warranty support or service. Once assembly, setup or use of the Product has been started, you must contact your local distributor or Horizon directly. This will enable Horizon to better answer your questions and service you in the event that you may need any assistance. For questions or assistance, please visit our website at www.horizonhobby.com, submit a Product Support Inquiry, or call the toll free telephone number referenced in the Warranty and Service Contact Information section to speak with a Product Support representative.

Inspection or Services

If this Product needs to be inspected or serviced and is compliant in the country you live and use the Product in, please use the Horizon Online Service Request submission process found on our website or call Horizon to obtain a Return Merchandise Authorization (RMA) number. Pack the Product securely using a shipping carton. Please note that original boxes may be included, but are not designed to withstand the rigors of shipping without additional protection. Ship via a carrier that provides tracking and insurance for lost or damaged parcels, as Horizon is not responsible for merchandise until it arrives and is accepted at our facility. An Online Service Request is available at http://www.horizonhobby.com/content/_service-center_render-service-center. If you do not have internet access, please contact Horizon Product Support to obtain a RMA number along with instructions for submitting your product for service. When calling Horizon, you will be asked to provide your complete name, street address, email address and phone number where you can be reached during business hours. When sending product into Horizon, please include your RMA number, a list of the included items, and a brief summary of the problem. A copy of your original sales receipt must be included for warranty consideration. Be sure your name, address, and RMA number are clearly written on the outside of the shipping carton.

NOTICE: Do not ship LiPo batteries to Horizon. If you have any issue with a LiPo battery, please contact the appropriate Horizon Product Support office.

Warranty Requirements

For Warranty consideration, you must include your original sales receipt verifying the proof-of-purchase date. Provided warranty conditions have been met, your Product will be serviced or replaced free of charge. Service or replacement decisions are at the sole discretion of Horizon.

Non-Warranty Service

Should your service not be covered by warranty, service will be completed and payment will be required without notification or estimate of the expense unless the expense exceeds 50% of the retail purchase cost. By submitting the item for service you are agreeing to payment of the service without notification. Service estimates are available upon request. You must include this request with your item submitted for service. Non-warranty service estimates will be billed a minimum of ½ hour of labor. In addition you will be billed for return freight. Horizon accepts money orders and cashier's checks, as well as Visa, MasterCard, American Express, and Discover cards. By submitting any item to Horizon for service, you are agreeing to Horizon's Terms and Conditions found on our website http://www.horizonhobby.com/content/_service-center_render-service-center.

ATTENTION: Horizon service is limited to Product compliant in the country of use and ownership. If received, a non-compliant Product will not be serviced. Further, the sender will be responsible for arranging return shipment of the un-serviced Product, through a carrier of the sender's choice and at the sender's expense. Horizon will hold non-compliant Product for a period of 60 days from notification, after which it will be discarded.

10/15

Contact Information

Country of Purchase	Horizon Hobby	Phone Number/Email Address	Address
United States of America	Horizon Service Center (Repairs and Repair Requests)	servicecenter.horizonhobby.com/ RequestForm/	4105 Fieldstone Rd Champaign, Illinois, 61822 USA
	Horizon Product Support (Product Technical Assistance)	productsupport@horizonhobby.com 877-504-0233	
	Sales	websales@horizonhobby.com 800-338-4639	
United Kingdom	Service/Parts/Sales: Horizon Hobby Limited	sales@horizonhobby.co.uk +44 (0) 1279 641 097	Units 1–4 , Ployters Rd, Staple Tye Harlow, Essex, CM18 7NS, United Kingdom
Germany	Horizon Technischer Service Sales: Horizon Hobby GmbH	service@horizonhobby.de +49 (0) 4121 2655 100	Christian-Junge-Straße 1 25337 Elmshorn, Germany
France	Service/Parts/Sales: Horizon Hobby SAS	infofrance@horizonhobby.com +33 (0) 1 60 18 34 90	11 Rue Georges Charpak 77127 Lieusaint, France

FCC Information

FCC ID: BRWSPMR4648A

This equipment has been tested and found to comply with the limits for a Class B digital device, pursuant to part 15 of the FCC Rules. These limits are designed to provide reasonable protection against harmful interference in a residential installation. This equipment generates, uses and can radiate radio frequency energy and, if not installed and used in accordance with the instructions, may cause harmful interference to radio communications.

However, there is no guarantee that interference will not occur in a particular installation. If this equipment does cause harmful interference to radio or television reception, which can be determined by turning the equipment off and on, the user is encouraged to try to correct the interference by one or more of the following measures:

- Reorient or relocate the receiving antenna.
- Increase the separation between the equipment and receiver.
- Connect the equipment to an outlet on a circuit different from that to which the receiver is connected.

This device complies with part 15 of the FCC rules. Operation is subject to the following two conditions:

- (1) This device may not cause harmful interference, and
- (2) this device must accept any interference received, including interference that may cause undesired operation.

NOTICE: Modifications to this product will void the user's authority to operate this equipment.

This product contains a radio transmitter with wireless technology which has been tested and found to be compliant with the applicable regulations governing a radio transmitter in the 2.400GHz to 2.4835GHz frequency range.

IC Information

IC ID: 6157A-SPMR4648A

This device complies with Industry Canada licence-exempt RSS standard(s). Operation is subject to the following two conditions: (1) this device may not cause interference, and (2) this device must accept any interference, including interference that may cause undesired operation of the device.

Compliance Information for the European Union



Convergence BNF Basic (EFL11050)

EU Compliance Statement: Horizon Hobby, LLC hereby declares that this product is in compliance with the essential requirements and other relevant provisions of the RED and EMC Directive.

A copy of the EU Declaration of Conformity is available online at: <http://www.horizonhobby.com/content/support-render-compliance>.

Convergence PNP (EFL11075)

EU Compliance Statement: Horizon Hobby, LLC hereby declares that this product is in compliance with the essential requirements and other relevant provisions of the EMC Directive.

Instructions for disposal of WEEE by users in the European Union



This product must not be disposed of with other waste. Instead, it is the user's responsibility to dispose of their waste equipment by handing it over to a designated collections point for the recycling of waste electrical and electronic equipment. The separate collection and recycling of your waste equipment at the time of

disposal will help to conserve natural resources and ensure that it is recycled in a manner that protects human health and the environment. For more information about where you can drop off your waste equipment for recycling, please contact your local city office, your household waste disposal service or where you purchased the product.



E328

Exploded View / Explosionszeichnung / Vue Éclatée / Vista Esplosa

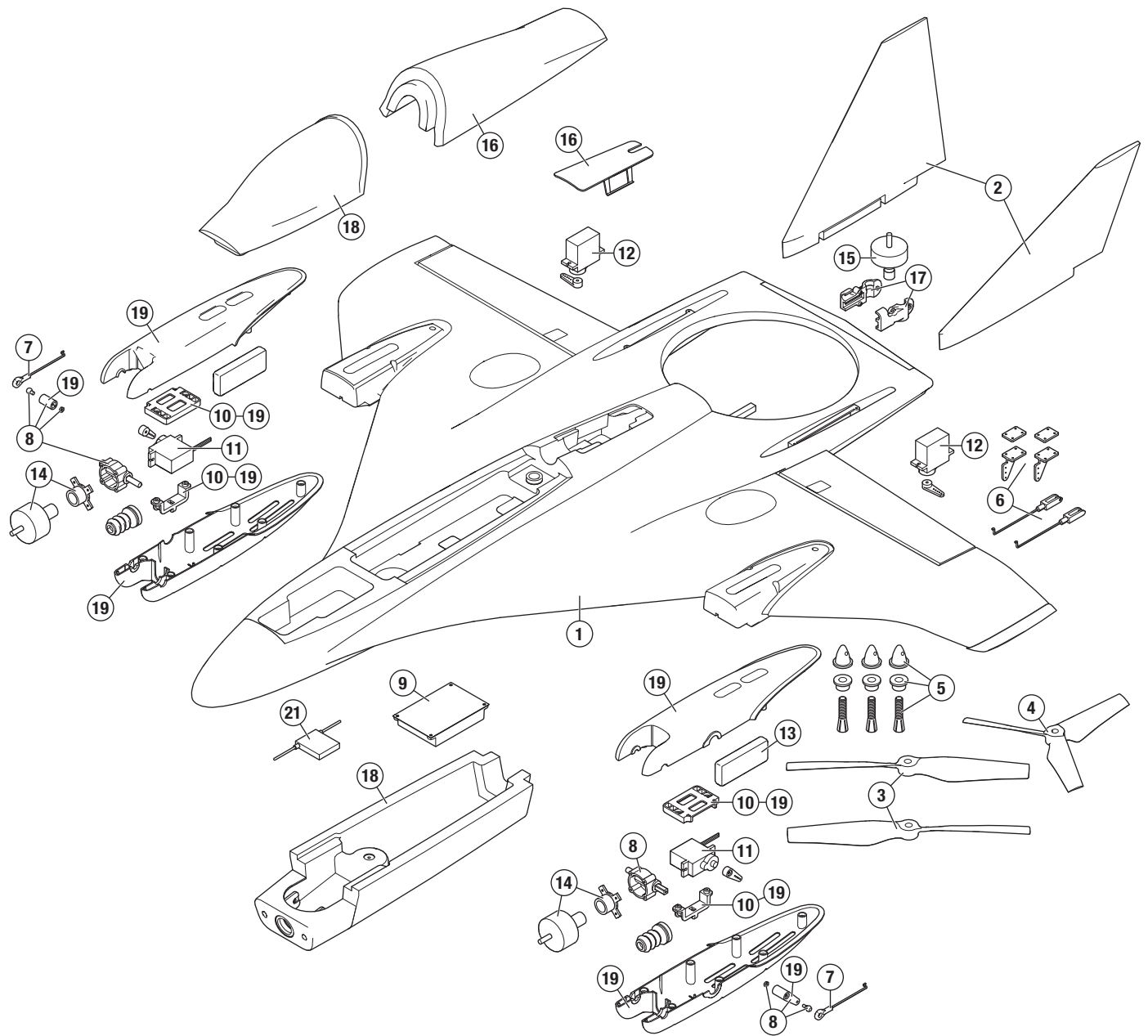

Replacement Parts • Ersatzteile • Pièces de rechange • Pezzi di ricambio

Part # / Nummer Numéro / Codice	Description	Beschreibung	Description	Descrizione	
1	EFL11001	Replacement Airframe	Ersatzflugzeugkörper	Structure de rechange	Telaio
2	EFL11002	Fin Set	Seitenleitwerksatz	Empennage	Set pinne
3	EFL11003	Main Propeller Set	Hauptpropellersatz	Set hélice principale	Elica principale
4	EFL11004	Tail Propeller	Heckpropeller	Hélice d'empennage	Elica di coda
5	EFL11005	Univ Prop Shaft	Universelle Propellerwelle	Arbre d'hélice universel	Albero elica univ.
6	EFL11006	Elevon Horns and Linkage Set	Quer-/Höhenruder Hörner und Gestängesatz	Guignol et tringlerie elevon	Set squadrette elevoni e comandi
7	EFL11007	Nacelle Ball Link and Linkage Set	Gondel Gelenkkopf und Gestängesatz	Tringlerie et rotules de nacelle	Set link uniball gondola e rinvi
8	EFL11008	Main Motor Mounts	Hauptmotorhalterungen	Supports moteur principal	Supporti motore principale
9	EFL11009	Flight Controller	Flugsteuerung	Contrôleur de vol	Flight controller
10	EFL11010	Univ Servo Mount	Universelle Servohalterung	Support universel de servo	Supporto servo univ.
11	EFL11011	Nacelle 9g metal gear servo	Gondel 9 g Metall-Getriebeservo	Servo nacelle 9g pignon métal	Servo metallico gondola 9 g
12	EFL11012	Elevon 9g plastic gear servo	Quer-/Höhenruder 9 g Kunststoff-Getriebeservo	Servo elevon 9g pignon plastique	Servo in plastica elevone 9 g
13	EFL11013	ESC 20A	Geschwindigkeitsregler 20 A	Contrôleur 20A	ESC 20 A
14	EFL11014	Main Motor	Hauptmotor	Moteur principal	Motore principale
15	EFL11015	Tail Motor	Heckmotor	Moteur d'empennage	Motore di coda
16	EFL11016	Canopy/FPV Hatch	Kanzel/FPV-Abdeckung	Verrière/Trappe FPV	Capottina/sportello FPV
17	EFL11017	Tail Motor Mount	Heckmotorhalterung	Support de moteur d'empennage	Supporto motore di coda
18	EFL11018	Bottom Hatch	Untere Abdeckung	Trappe inférieure	Sportello inferiore fusoliera
19	EFL11019	Nacelle Set	Gondelsatz	Set de nacelle	Set gondole
20	EFL11020	Decal Set	Decalsatz	Planche de décoration	Decalcomanie
21	SPM4648	Spektrum Quad Race Serial Receiver w/Diversity	Serieller Spektrum Quad Race Empfänger mit Diversität	Récepteur serial pour quadcoptère avec Diversity	Ricevente seriale Spektrum Quad Race con modulo Diversity

Optional Parts • Optionale Bauteile • Pièces optionnelles • Pezzi opzionali

Part # / Nummer Numéro / Codice	Description	Beschreibung	Description	Descrizione
SPMVC650	650TVL CCD FPV Camera NTSC	650TVL CCD FPV-Kamera NTSC	Caméra FPV 650TVL CCD NTSC	Videocamera FPV NTSC 650 TVL CCD
SPMVT025	Video transmitter, VTX 25MW	Videosender, VTX 25MW	Émetteur vidéo 25mW	Trasmittitore video VTX 25 MW
SPMVT200	Video transmitter, VTX 200MW	Videosender, VTX 200MW	Émetteur vidéo 200mW	Trasmittitore video VTX 200 MW
SPMVT600	Video transmitter, VTX 600MW	Videosender, VTX 600MW	Émetteur vidéo 600mW	Trasmittitore video VTX 600 MW
SPMVX5802	RHCP Omni Right Angle Connector	RHCP Omni Winkelstecker	Antenne omnidirectionnelle RHCP avec prise à angle droit	Connettore ad angolo retto RHCP Omni
SPMA9556	Air Telemetry Flight Pack Voltage Sensor: EC3	Flugtelemetrie Packspannungssensor: EC3	Adaptateur alimentation pour capteur télémétrique de tension EC3	Sensore voltaggio per telemetria: EC3
SPMVM430C	Spektrum 4.3 inch Video Monitor with Headset	Spektrum 4,3 Zoll Videomonitor mit Headset	Moniteur vidéo Spektrum 4,3" avec lunettes	Display Spektrum 4,3" con visore
EFLAEC302	EC3 Battery Connector, Female (2)	EC3 Akkukabel, Buchse (2)	Prise EC3 femelle (2pc)	EC3 connettore femmina x batteria (2)
EFLB22003S30	11.1V 3S 30C 2200MAH Li-Po	11,1V 3S 30C 2200mAh LiPo	11,1V 3S 30C 2200MAH Li-Po	11,1V 3S 30C 2200MAH Li-Po
EFLB30003S30	11.1V 3S 30C 3000MAH Li-Po	11,1V 3S 30C 3000mAh LiPo	11,1V 3S 30C 3000MAH Li-Po	11,1V 3S 30C 3000MAH Li-Po
DYNC2020A	Prophet Sport Duo 50W x 2 AC Battery Charger	Dynamite Prophet Sport Duo 50W x 2 AC Ladegerät, EU	Chargeur Prophet Sport Duo 50W x 2 AC	Caricabatterie Prophet Sport Duo 50W x 2 AC
EFLA111	Li-Po Cell Voltage Checker	Li-Po Cell Voltage Checker	Testeur de tension d'éléments Li-Po	Voltmetro verifica batterie LiPo
DYN1405	Li-Po Charge Protection Bag, Large	Dynamite LiPoCharge Protection Bag groß	Sac de charge Li-Po, grand modèle	Sacchetto grande di protezione per carica LiPo
DYN1400	Li-Po Charge Protection Bag, Small	Dynamite LiPoCharge Protection Bag klein	Sac de charge Li-Po, petit modèle	Sacchetto piccolo di protezione per carica LiPo
	DXe DSMX 6-Channel Transmitter	Spektrum DXe DSMX 6-Kanal-Sender	Émetteur DXe DSMX 6 voies	DXe DSMX trasmittente 6 canali
	DX6 DSMX 6-Channel Transmitter	Spektrum DX6 DSMX 6-Kanal-Sender	Émetteur DX6 DSMX 6 voies	DX6 DSMX trasmittente 6 canali
	DX7G2 DSMX 7-Channel Transmitter	Spektrum DX7 DSMX 7-Kanal-Sender	Émetteur DX7 DSMX 7 voies	DX7 DSMX trasmittente 7 canali
	DX8G2 DSMX 8-Channel Transmitter	Spektrum DX8G2 DSMX 8-Kanal-Sender	Émetteur DX8G2 DSMX 8 voies	DX8G2 DSMX trasmittente 8 canali
	DX9 DSMX 9-Channel Transmitter	Spektrum DX9 DSMX 9-Kanal-Sender	Émetteur DX9 DSMX 9 voies	DX9 DSMX trasmittente 9 canali
	DX18 DSMX 18-Channel Transmitter	Spektrum DX18 DSMX 18-Kanal-Sender	Émetteur DX18 DSMX 18 voies	DX18 DSMX trasmittente 18 canali
	DX20 DSMX 20-Channel Transmitter	Spektrum DX20 DSMX 20-Kanal-Sender	Émetteur DX20 DSMX 20 voies	DX20 DSMX trasmittente 20 canali

E-flite[®]
ADVANCING ELECTRIC FLIGHT



CONVERGENCE[™]
VTOL

© 2016 Horizon Hobby, LLC.

E-flite, AS3X, DSM, DSM2, DSMX, the DSMX logo, Bind-N-Fly, BNF, the BNF logo, ModelMatch, Dynamite, EC3, Prophet, Z-Foam and the Horizon Hobby logo are trademarks or registered trademarks of Horizon Hobby, LLC.

The Spektrum trademark is used with permission of Bachmann Industries, Inc.

Futaba is a registered trademark of Futaba Denshi Kogyo Kabushiki Kaisha Corporation of Japan.

All other trademarks, service marks and logos are property of their respective owners.

US 8,672,726. Other patents pending.

<http://www.e-fliterc.com/>