

HORIZON[®]
H O B B Y

E-flite[®]
ADVANCING ELECTRIC FLIGHT

HAVOC *Xe*TM



*Instruction Manual
Bedienungsanleitung
Manuel d'utilisation
Manuale di Istruzioni*

EA
ELITE AEROSPORTS
Produced under license

SAFE[®] 

SAFE[®] Select Technology, Optional Flight Envelope Protection

Bind-N-Fly[®] Plug-N-Play[®]
BASIC

NOTICE

All instructions, warranties and other collateral documents are subject to change at the sole discretion of Horizon Hobby, LLC. For up-to-date product literature, visit www.horizonhobby.com or www.towerhobbies.com and click on the support or resources tab for this product.

Meaning of Special Language:

The following terms are used throughout the product literature to indicate various levels of potential harm when operating this product:

WARNING: Procedures, which if not properly followed, create the probability of property damage, collateral damage, and serious injury OR create a high probability of superficial injury.

CAUTION: Procedures, which if not properly followed, create the probability of physical property damage AND a possibility of serious injury.

NOTICE: Procedures, which if not properly followed, create a possibility of physical property damage AND little or no possibility of injury.

 **WARNING:** Read the ENTIRE instruction manual to become familiar with the features of the product before operating. Failure to operate the product correctly can result in damage to the product, personal property and cause serious injury.

This is a sophisticated hobby product. It must be operated with caution and common sense and requires some basic mechanical ability. Failure to operate this Product in a safe and responsible manner could result in injury or damage to the product or other property. This product is not intended for use by children without direct adult supervision. Do not use with incompatible components or alter this product in any way outside of the instructions provided by Horizon Hobby, LLC. This manual contains instructions for safety, operation and maintenance. It is essential to read and follow all the instructions and warnings in the manual, prior to assembly, setup or use, in order to operate correctly and avoid damage or serious injury.

14+

AGE RECOMMENDATION:
Not for children under 14 years. This is not a toy.



WARNING AGAINST COUNTERFEIT PRODUCTS: If you ever need to replace your Spektrum receiver found in a Horizon Hobby product, always purchase from Horizon Hobby, LLC or a Horizon Hobby authorized dealer to ensure authentic high-quality Spektrum product. Horizon Hobby, LLC disclaims all support and warranty with regards, but not limited to, compatibility and performance of counterfeit products or products claiming compatibility with DSM or Spektrum technology.

Safety Precautions and Warnings

As the user of this product, you are solely responsible for operating in a manner that does not endanger yourself and others or result in damage to the product or the property of others.

- Always keep a safe distance in all directions around your model to avoid collisions or injury. This model is controlled by a radio signal subject to interference from many sources outside your control. Interference can cause momentary loss of control.
- Always operate your model in open spaces away from full-size vehicles, traffic and people.
- Always carefully follow the directions and warnings for this and any optional support equipment (chargers, rechargeable battery packs, etc.).
- Always keep all chemicals, small parts and anything electrical out of the reach of children.
- Always avoid water exposure to all equipment not specifically designed and protected for this purpose. Moisture causes damage to electronics.
- Never place any portion of the model in your mouth as it could cause serious injury or even death.
- Never operate your model with low transmitter batteries.
- Always keep aircraft in sight and under control.
- Always use fully charged batteries.
- Always keep transmitter powered on while aircraft is powered.
- Always remove batteries before disassembly.
- Always keep moving parts clean.
- Always keep parts dry.
- Always let parts cool after use before touching.
- Always remove batteries after use.
- Always ensure failsafe is properly set before flying.
- Never operate aircraft with damaged wiring.
- Never touch moving parts.

Quick Start Information

Transmitter Setup	Set up your transmitter using the transmitter setup chart		
Dual Rates		Hi Rate	Low Rate
	Ail	13mm	10mm
	Ele	▲15mm ▼15mm	▲11mm ▼10mm
	Rud	28mm	20mm
Flaps	Full ▼=30mm	Half ▼=17mm	
Center of Gravity (CG)	100mm - 125mm back from leading edge of wing at the fuselage		
Flight Timer Setting	3.5 minutes		

Box Contents

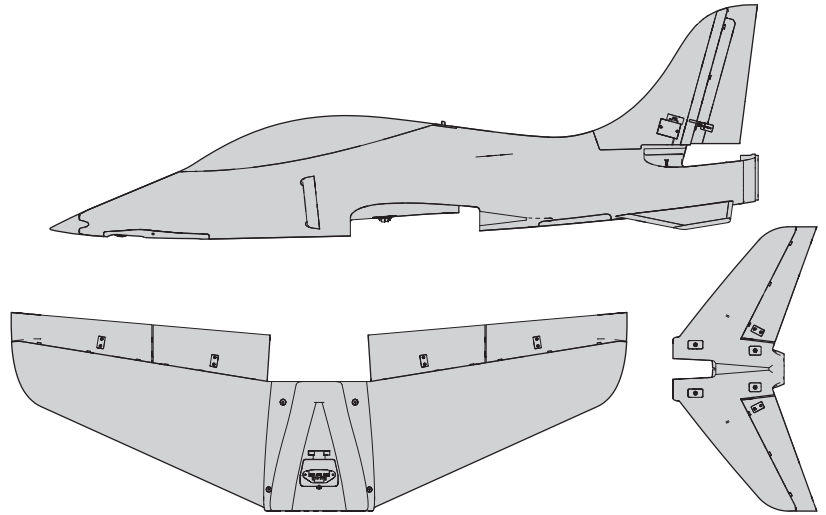

Specifications

		BNF BASIC	PNP PLUG-N-PLAY
	Motor: 3270-2000kV Brushless outrunner (EFLM2000DF)	Installed	Installed
	ESCs: 100-Amp Pro Switch-Mode BEC Brushless ESC 270mm Lead (EFLA10100AEC5)	Installed	Installed
	Servos: 13 gram metal geared servos (5x SPMSA450) (2x SPMSA450R)	Installed	Installed
	Receiver: Spektrum™ AR636A 6-Channel Sport Receiver (SPMAR636)	Installed	Required to Complete
	Recommended Battery: 22.2V 6S 4000-8000mAh 30C Li-Po (EFLB50006S30) with EC5 or IC5	Required to Complete	Required to Complete
	Recommended Battery Charger: 6-cell Li-Po battery balancing charger	Required to Complete	Required to Complete
	Recommended Transmitter: Full-Range 6 channel 2.4GHz with Spektrum DSMX® technology with adjustable Dual Rates.	Required to Complete	Required to Complete

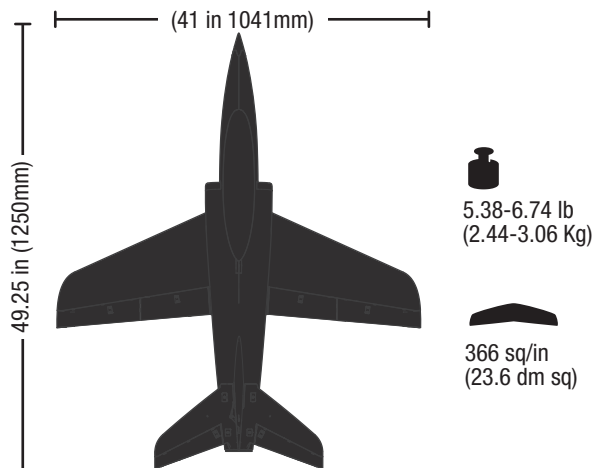

As of this printing, you may be required to register with the FAA if you own this product.

For up-to-date information on how to register with the FAA, please visit <https://registermyuas.faa.gov/>. For additional assistance on regulations and guidance on UAS usage, visit knowbeforeyoufly.org/.

Table of Contents

SAFE® Select Technology (BNF Basic).....	4
Preflight.....	4
Model Assembly	4
Model Assembly Continued	5
Receiver Installation (PNP)	5
Transmitter Setup (BNF)	6
Battery Installation and ESC Arming	7
Center of Gravity	7
Binding / Enable or Disable SAFE Select (BNF)	8
SAFE® Select Switch Designation	9
Control Surface Centering	9
Initial Flight Setup	9
Control Surface Direction	10
Control Horn and Servo Arm Settings	10
AS3X Control Direction Test (BNF)	11
In Flight Trimming (BNF).....	11
Flying Tips and Repairs.....	12
SAFE Select Flying Tips.....	12
Post Flight	13
Motor Service	13
Troubleshooting Guide AS3X	13
Troubleshooting Guide	14
Replacement Parts.....	15
Optional Parts	15
Recommended Receivers (PNP)	15
AMA National Model Aircraft Safety Code	16
Limited Warranty	17
Contact Information	17
FCC Information	18
IC Information	18
Compliance Information for the European Union.....	18

RECEIVER BIND INFORMATION

Channels	6
Frequency	2404 – 2476 MHz
Compatibility	DSM2 and DSMX

To receive product updates, special offers and more, register your product at <https://www.horizonhobby.com/content/e-flite-rc>

SAFE® Select Technology (BNF Basic)

The BNF Basic version of this airplane includes SAFE Select technology which can offer an extra level of protection in flight. Use the following instructions to make the SAFE Select system active and assign it to a switch. When enabled, SAFE Select prevents the airplane from banking or pitching past predetermined limits, and automatic self-leveling keeps the airplane flying in a straight and level attitude when the aileron, elevator and rudder sticks are at neutral.

SAFE Select is enabled or disabled during the bind process. When the airplane is bound with SAFE Select enabled, a switch can be assigned to toggle between SAFE Select mode and AS3X mode. AS3X® technology remains active with no banking limits or self leveling any time SAFE Select is disabled or OFF.

SAFE Select can be configured three ways;

- SAFE Select Off: Always in AS3X mode
- SAFE Select On- no switch assigned: Always in SAFE Select mode
- SAFE Select On with a switch assigned: Switch toggles between SAFE Select mode and AS3X mode

Preflight

1. Remove and inspect contents.	9. Make sure linkages move freely.
2. Read this instruction manual thoroughly.	10. Test the flap and retract operation.
3. Charge the flight battery.	11. Perform the Control Direction Test with the transmitter.
4. Setup Transmitter using transmitter setup chart.	12. Perform the AS3X Control Direction Test with the aircraft.
5. Fully assemble the airplane.	13. Adjust flight controls and transmitter.
6. Install the flight battery in the aircraft (once it has been fully charged).	14. Perform a radio system Range Test.
7. Check the Center of Gravity (CG).	15. Find a safe open area to fly.
8. Bind the aircraft to your transmitter.	16. Plan flight for flying field conditions.

Model Assembly

Horizontal Tail Installation

1. Deflect the rudder to one side to make more room.
2. Connect the elevator servo leads to the servo extensions in the pocket below the rudder. Secure each pair of connectors with a piece of tape.
3. Tuck the servo leads into the pocket below the rudder as you slide the stabilizer into place.
4. Install the four 3mm x 16mm counter sunk machine screws in the stabilizer.

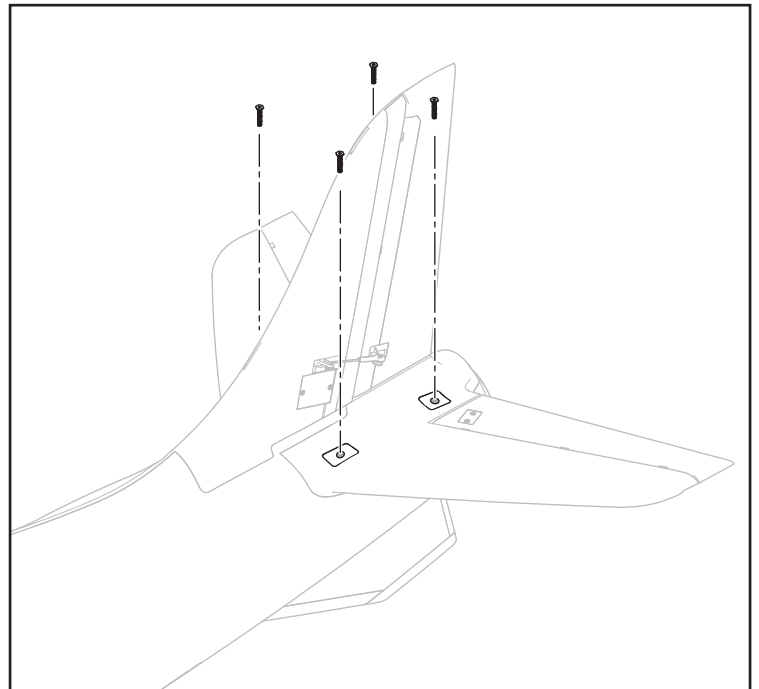
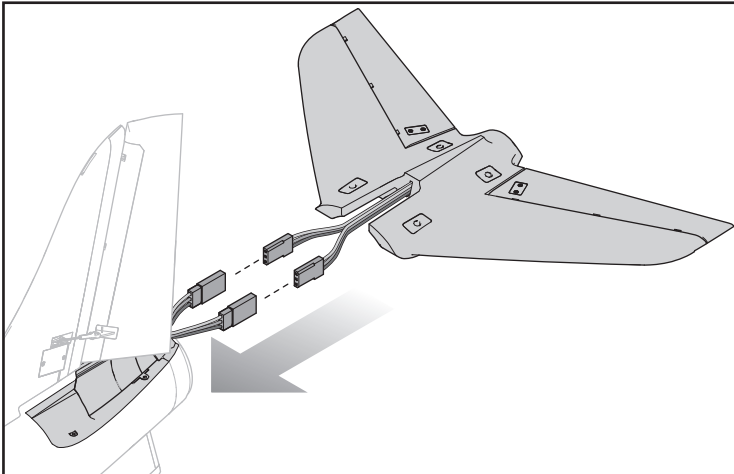

Model Assembly *Continued*

Wing Installation

We recommend using the included servo connector retainer clips on all five servo connections.

1. There are two Aileron and two Flap leads, and one retract lead extending from the wing and from the fuselage. Be sure all five leads are connected properly per the corresponding labels on each (AILE to AILE, FLAP to FLAP and GEAR to GEAR).
2. Align the wing with the wing saddle on the fuselage and carefully feed the wire leads and servo connectors into the fuselage while seating the wing in the saddle.
3. Insert the five 3mm x 32mm counter sunk machine screws in the holes in the bottom of the wing. Thread each of the bolts only a few threads into the fuselage until all are started.
4. Ensure the wing fits tight against the wing saddle with no gap.

CAUTION: DO NOT crush or otherwise damage the wiring when attaching the wing to the fuselage.

5. Tighten the bolts alternating from side to side until they are snug.

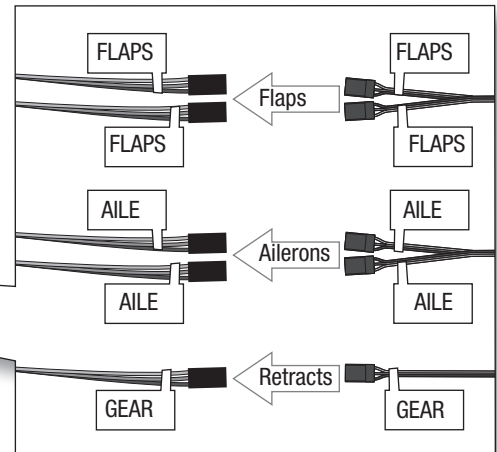
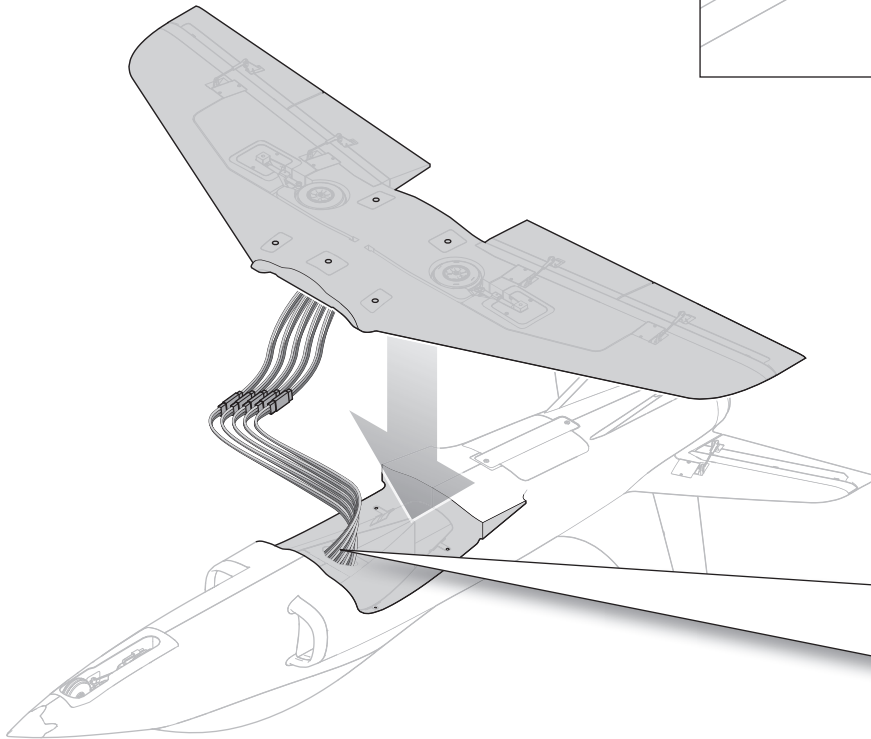
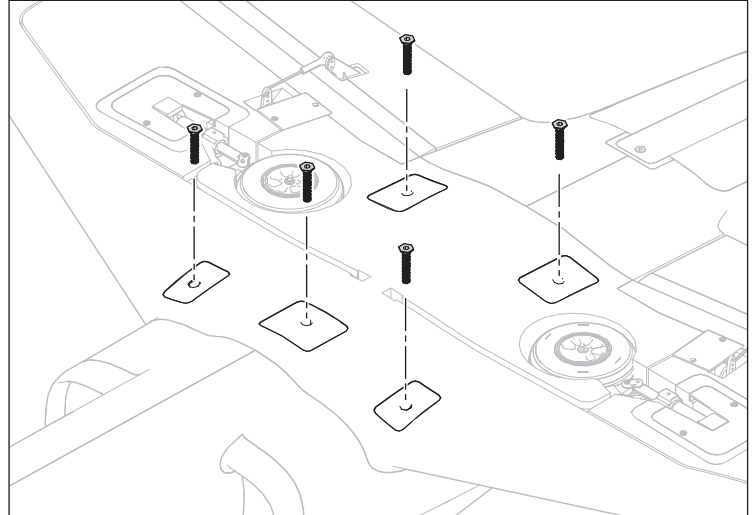

Receiver Installation (PNP)

The Spektrum AR636 receiver is recommended for this airplane. If you choose to install another receiver, ensure that it is at least a 6-channel full range receiver. Refer to your receiver manual for correct installation and operation instructions.

Installation (AR636 shown)

1. Mount the receiver parallel to the length of the fuselage as shown. Use heavy duty double-sided servo tape.

NOTICE: Incorrect installation of the receiver could cause a crash.

2. Attach the appropriate control surfaces to their respective ports on the receiver using the chart in the illustration.

AR636 Port Assignments

BND/PRG = BIND

- | | |
|--------------|--------------|
| 1 = Throttle | 4 = Rudder |
| 2 = Ailerons | 5 = Retracts |
| 3 = Elevator | 6 = Flaps |

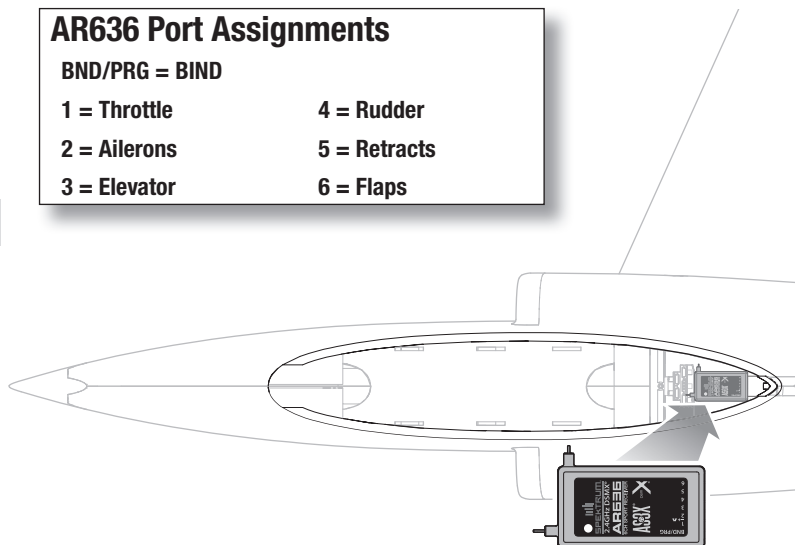

Transmitter Setup (BNF)

IMPORTANT: After you set up your model, always rebind the transmitter and receiver to set the desired failsafe positions.

The GEAR Channel (CH 5) controls the retractable landing gear. The FLAP Channel (CH 6) controls the flaps. If you are using a 6 channel transmitter, The FLAP Channel (CH 6) can be used to toggle SAFE select. With the values listed below it will turn SAFE on for half and full flap positions and AS3X will be on for no flaps position.

To use the flap channel for the SAFE select switch the values must be set to +100 and -100 and the speed set to 0 temporarily to assign the safe switch in the flap system menu. Then change the flap systems values back to the listing in the TX setup. See the SAFE Select Switch Designation section of this manual to assign the switch for SAFE select.

Dual Rates

Attempt your first flights in Low Rate. For landings, use high rate elevator.

NOTICE: To ensure AS3X technology functions properly, do not lower rate values below 50%. If less control deflection is desired, manually adjust the position of the pushrods on the servo arm

NOTICE: If oscillation occurs at high speed, refer to the Troubleshooting Guide for more information.

Expo

After first flights, you may adjust expo in your transmitter.

† Some of the terminology and function locations used in the iX12 programming may be slightly different than other Spektrum AirWare™ radios. The names given in parenthesis correspond to the iX12 programming terminology. Consult your transmitter manual for specific information about programming your transmitter.

* Flap programming values may vary slightly. For your initial flights use the recommended flap travel settings provided in the Flaps section and adjust the flap travel to your preference on subsequent flights.

Computerized Transmitter Setup	
Start all transmitter programming with a blank ACRO model (perform a model reset), then name the model.	
Set Dual Rates to	HIGH 100% LOW 70%
Set Servo Travel to	100%
Set Throttle Cut to	-130%
Set Retract Channel to	Reverse
Set Aileron Expo to	High Rate 18% Low Rate 10%
Set Elevator Expo to	High Rate 12% Low Rate 6%
Set Rudder Expo to	High Rate 10% Low Rate 5%
DXe	Refer to spektrumrc.com for the appropriate download setup.
DX6i	1. Go to the SETUP LIST MENU
	2. Set MODEL TYPE: ACRO
	3. Go to ADJUST LIST MENU
	4. Set TRAVEL: FLAPS ↑-100 ↓125
	5. Set FLAPS: Norm ↓ 0 Flap Elev 0 LAND ↑-100 Flap Elev 15
DX7S DX8	1. Go to the SYSTEM SETUP
	2. Set MODEL TYPE: AIRPLANE
	3. Set WING TYPE: 1 AIL 1 FLAP
	4. Go to the FUNCTION LIST
	5. Set TRAVEL: FLAPS ↑-100 ↓125
	6. Set FLAP SYSTEM: Choose Flap NORM: 0% FLAP 10% Elevator MID: 50% FLAP 15% Elevator LAND: 100% FLAP SPEED 2.0S: SWITCH = FLAP
DX6e DX6 (Gen2) DX7 (Gen2) DX8e DX8 (Gen2)	1. Go to the SYSTEM SETUP (Model Utilities)†
	2. Set MODEL TYPE: AIRPLANE
	3. Set AIRCRAFT TYPE (Model Setup, Aircraft Type)†: WING: 1 AIL 1 FLAP
	4. Set CHANNEL ASSIGN (Model Setup, Channel Assign)†: (Default switch assignments with a new model setup) Gear (CH5): SWITCH A Flap (CH6): SWITCH D
DX9 DX10t	5. Go to the FUNCTION LIST (Model Adjust)†
	6. Set TRAVEL: FLAPS ↑-100 ↓125
DX18 DX20 iX12	7. Set FLAP SYSTEM: SELECT SWITCH D: POS 0: 0% FLAP* POS 1: 50% FLAP* 10% Elevator POS 2: 100% FLAP* 15% Elevator SPEED 2.0

Battery Installation and ESC Arming

Battery Selection

A 6S 4000-8000mAh LiPo battery is required. The Spektrum 5000mAh 22.2V 6S 30C LiPo battery (SPMX50006S30) is recommended. Refer to the Optional Parts List for other recommended batteries. If using a battery other than those listed, the battery should be within the range of capacity, dimensions and weight of the Spektrum Li-Po battery packs to fit in the fuselage. Be sure the model balances at the recommended CG before flying.

1. Lower the throttle and throttle trim to the lowest settings. Power on the transmitter, then wait 5 seconds.
2. Remove the battery hatch.
3. For added security, apply the loop side (soft side) of the optional hook and loop tape to the bottom of your battery, and the hook side to the battery tray.
4. Install the fully charged battery in the center of the battery compartment as shown. Secure using the hook and loop straps.
5. Connect the battery to the ESC. If you have not completed the bind sequence, do so at this time as outlined in this manual.

CAUTION: Always keep hands away from the rotor. When armed, the motor will turn the rotor in response to any throttle movement.

6. Keep the aircraft immobile and away from wind or the system will not initialize.
 - The motor will emit a series of rising tones when the battery is connected, and then 6 even tones indicating the number of cells connected.
 - An LED will light on the receiver when it is initialized
7. Reinstall the battery hatch.

ESC Tones: If the ESC sounds a continuous double beep after the flight battery is connected, recharge or replace the battery.

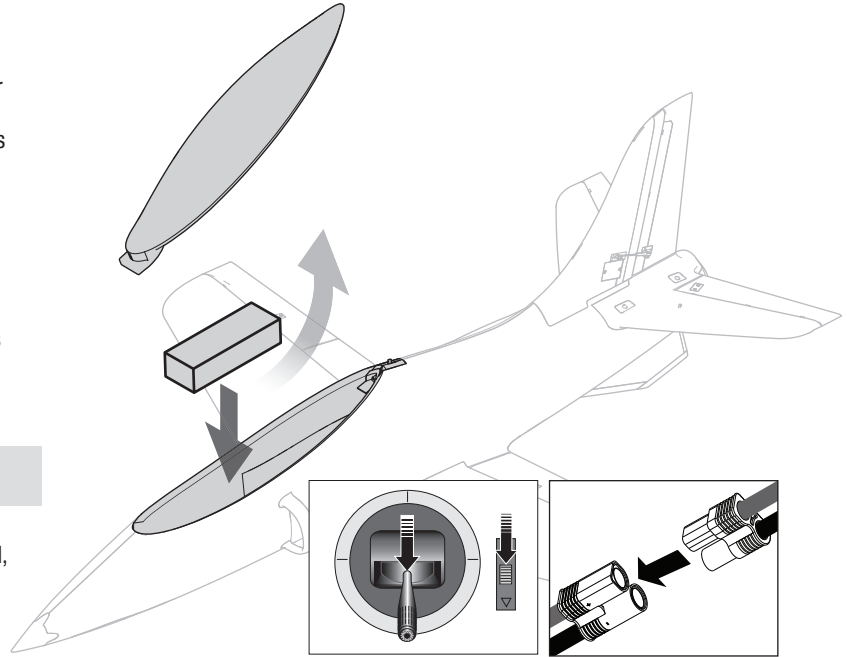

ESC Error Tones	Tone Meaning	Possible problem
Continuous slow single tones	Abnormal throttle signal	Transmitter and receiver not bound
		Throttle lead damaged or not plugged into receiver
		Throttle lead plugged into receiver backward
Continuous rapid single tones	Throttle signal not at low position	Throttle stick not at low position
		Throttle travel reduced below 100%
		Throttle reversed
		Throttle trim raised
Continuous double tones	Battery voltage is beyond acceptable range	Verify battery is a 22.2V 6-cell LiPo
		Verify battery is fully charged

Center of Gravity

The Center of Gravity (CG) location is measured from the leading edge of the wing at the front of the wing saddle

CAUTION: Install the battery but do not connect it to the ESC while checking the CG. Personal injury may result.

100-125mm

From the front of the wing saddle on the fuselage.

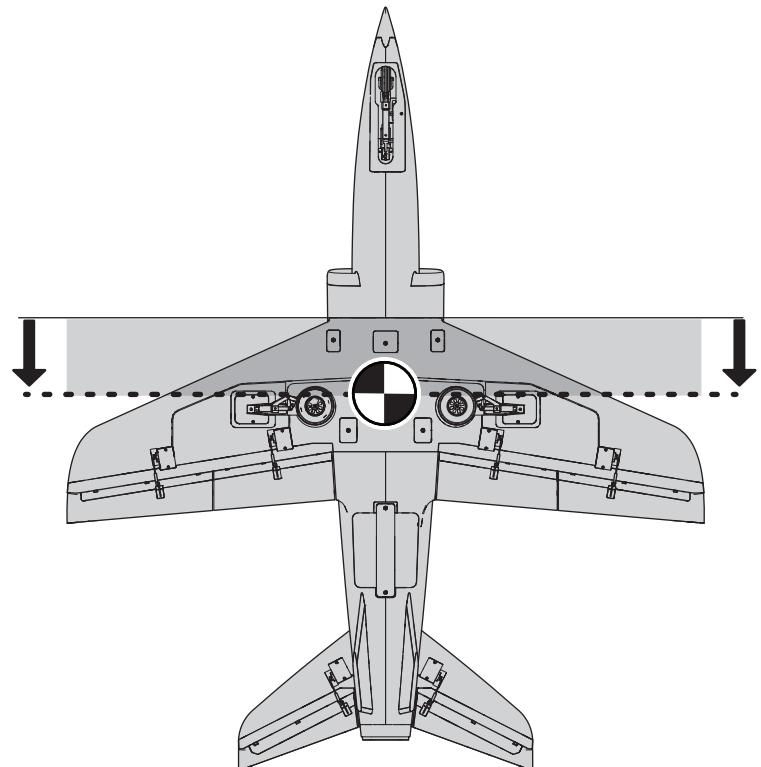
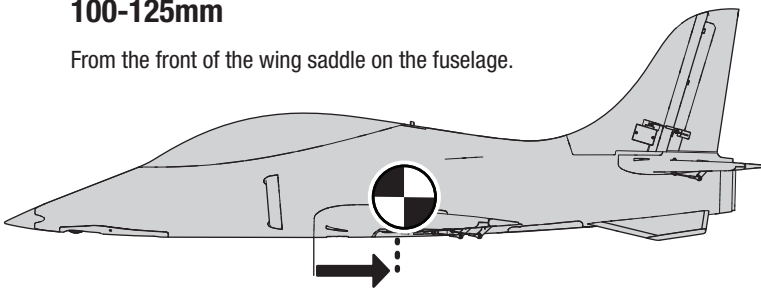

Transmitter and Receiver Binding / Enable or Disable SAFE Select (BNF)

This product requires an approved Spektrum™ DSM2®/DSMX® compatible transmitter. Visit www.bindnfly.com for a complete list of approved transmitters.

The aircraft has an optional SAFE Select feature, which can be switched ON or OFF easily by binding in a specific manner as described below.

IMPORTANT: Before binding a transmitter, read the Transmitter Setup section of this manual to ensure that your transmitter is properly programmed for this aircraft.

Bind Plug Installation

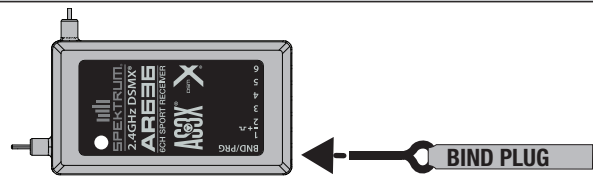

Switching ON SAFE Select Binding Sequence

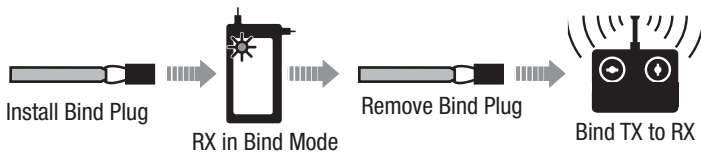

Switching OFF SAFE Select Binding Sequence

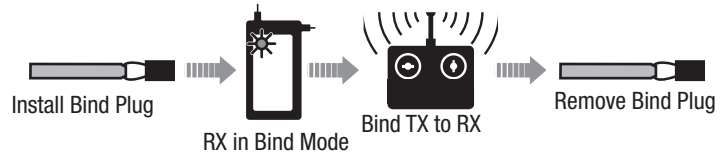

Binding Procedure / Switching ON SAFE Select

IMPORTANT: The included AR636 receiver has been programmed for operation specifically for this aircraft. Refer to the receiver manual for correct setup if the receiver is replaced or is used in another aircraft.

CAUTION: When using a Futaba® transmitter with a Spektrum DSM® module, you must reverse the throttle channel and rebind. Refer to your Spektrum module manual for binding and failsafe instructions. Refer to your Futaba transmitter manual for instructions on reversing the throttle channel.

1. Move the transmitter controls to neutral (flight controls: rudder, elevators and ailerons) or to low positions (throttle, throttle trim).*
2. Install a bind plug in the receiver bind port.
3. Place the aircraft level on its wheels, then connect the flight battery to the ESC. The motor will produce a series of sounds. The orange bind LED on the receiver will begin to flash rapidly.
4. **Remove the bind plug from the bind port.**
5. Take three steps away from the aircraft /receiver and then put the transmitter in bind mode. Refer to your transmitter's manual for specific binding instructions. **IMPORTANT:** Do not point the transmitter's antenna directly at the receiver while binding. **IMPORTANT:** Keep away from large metal objects while binding.
6. The receiver is bound to the transmitter when the orange bind light on the receiver stays orange. The ESC will produce a series of sounds. The tones indicate the ESC is armed, provided the throttle stick and throttle trim are low enough to trigger arming.

IMPORTANT: Once bound, the receiver will retain its bind settings for that transmitter until it has been intentionally changed, even when power is cycled ON and OFF. Repeat the binding process as necessary.

SAFE Select ON Indication

Every time the receiver is powered ON the surfaces will cycle back and forth **twice** with a slight pause at neutral position to indicate that SAFE Select is switched ON.

The throttle will not arm if the transmitter's throttle control is not put at the lowest position. If problems are encountered, follow the binding instructions and refer to the transmitter troubleshooting guide for other instructions. If needed, contact the appropriate Horizon Product Support office.

Binding Procedure / Switching OFF SAFE Select

IMPORTANT: The included AR636 receiver has been programmed for operation specifically for this aircraft. Refer to the receiver manual for correct setup if the receiver is replaced or is used in another aircraft.

CAUTION: When using a Futaba® transmitter with a Spektrum DSM module, you must reverse the throttle channel and rebind. Refer to your Spektrum module manual for binding and failsafe instructions. Refer to your Futaba transmitter manual for instructions on reversing the throttle channel.

1. Move the transmitter controls to neutral (flight controls: rudder, elevators and ailerons) or to low positions (throttle, throttle trim).*
2. Install a bind plug in the receiver bind port.
3. Place the aircraft level on its wheels, then connect the flight battery to the ESC. The motor will produce a series of sounds. **The orange bind LED on the receiver will begin to flash rapidly. DO NOT remove the bind plug at this time.**
4. Take three steps away from the aircraft /receiver and then put the transmitter in bind mode. Refer to your transmitter's manual for specific binding instructions. **IMPORTANT:** Do not point the transmitter's antenna directly at the receiver while binding. **IMPORTANT:** Keep away from large metal objects while binding.
5. The receiver is bound to the transmitter when the orange bind light on the receiver stays orange. The ESC will produce a series of sounds. The tones indicate the ESC is armed, provided the throttle stick and throttle trim are low enough to trigger arming.
6. **Remove the bind plug from the bind port.**

IMPORTANT: Once bound, the receiver will retain its bind settings for that transmitter until it has been intentionally changed, even when power is cycled ON and OFF. Repeat the binding process as necessary.

SAFE Select OFF Indication

Every time the receiver is powered ON the surfaces will cycle back and forth **once** to indicate that SAFE Select has been switched OFF.

The throttle will not arm if the transmitter's throttle control is not put at the lowest position. If problems are encountered, follow the binding instructions and refer to the transmitter troubleshooting guide for other instructions. If needed, contact the appropriate Horizon Product Support office.

*Failsafe

If the receiver loses transmitter communication, the failsafe will activate. When activated, failsafe moves the throttle channel to its preset failsafe position (low throttle) that was set during binding. All other channels move to actively level the aircraft in flight.

SAFE® Select Switch Designation

SAFE® Select technology can be assigned to any open switch (2 or 3 position) controlling a channel (5–9) on your transmitter. Once assigned to a switch, SAFE select ON gives you the flexibility to choose SAFE technology or AS3X mode while in flight. If the aircraft is bound with SAFE select OFF, the aircraft will be in AS3X mode exclusively.

IMPORTANT: Before assigning your desired switch, ensure that the travel for that channel is set at 100% in both directions and the aileron, elevator, rudder and throttle are all on high rate with the travel at 100%.

CAUTION: Keep all body parts well clear of the propeller and keep the aircraft securely restrained in case of accidental throttle activation.

TIP: SAFE Select is assignable on any unused channels 5–9. See your transmitter manual for more information about assigning a switch to a channel.

TIP: Use your radio channel monitor to confirm that the four primary channels are showing 100% travel while assigning the switch.

TIP: Use the channel monitor to make sure the switch you are assigning for SAFE Select is active and driving a channel between 5-9 and that it is traveling 100% in each direction.

TIP: Make sure your four primary channels are not reversed if you are having trouble assigning a SAFE Select switch.

Assigning a switch

1. Bind the aircraft to choose SAFE Select ON. This will allow the system to be assigned to a switch.
2. Hold both transmitter sticks to the inside bottom corners and toggle the desired switch 5 times (1 toggle = full up and down) to assign that switch. The control surfaces of the aircraft will move, indicating the switch has been selected.

Repeat the process to assign a different switch or to deactivate the current switch if desired.

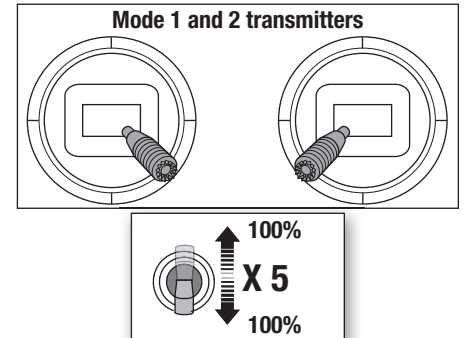

Control Surface Centering

After assembly and transmitter setup, confirm that the control surfaces are centered. The model must be powered up bound to the transmitter in AS3X mode, with the throttle left at zero. When enabled, SAFE mode is active at power up. AS3X mode is activated when the throttle is raised above 25% for the first time after being powered on. It is normal for the control surfaces to respond to aircraft movement if the aircraft is in AS3X or SAFE modes.

1. Verify the trims and subtrims on your transmitter are zero
2. Power up the model in AS3X mode and leave the throttle at zero

NOTICE: Be aware of the pushrod bottoming out in the ball linkage. Do not thread the pushrod too far into the ball link or the pushrod will damage the ball link and protrude into the area needed for the control ball.

3. Center the rudder with the rudder fillet. If adjustment is required, turn the ball link on the linkage to change the length between the servo arm and the control horn until the edge of the rudder is aligned with the rudder fillet.
4. With the flap switch in the up position, center the flaps by aligning the inboard end of the flap with the wing fillet. Adjust the linkage length as in step 3 as necessary.
5. Center the ailerons by aligning the inboard end of the aileron with the flap. Adjust the linkage length as in step 3 as necessary.
6. The center position for the elevator should be trimmed slightly down from neutral (approximately 2mm) when the CG is in the middle of the recommended range. Adjust the linkage length as in step 3 as necessary.

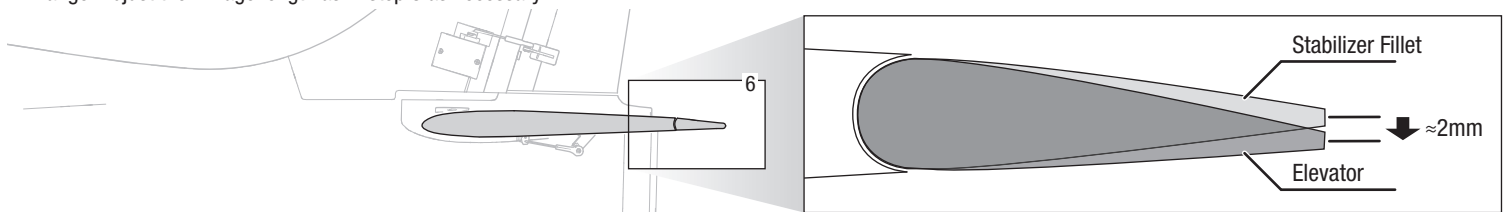
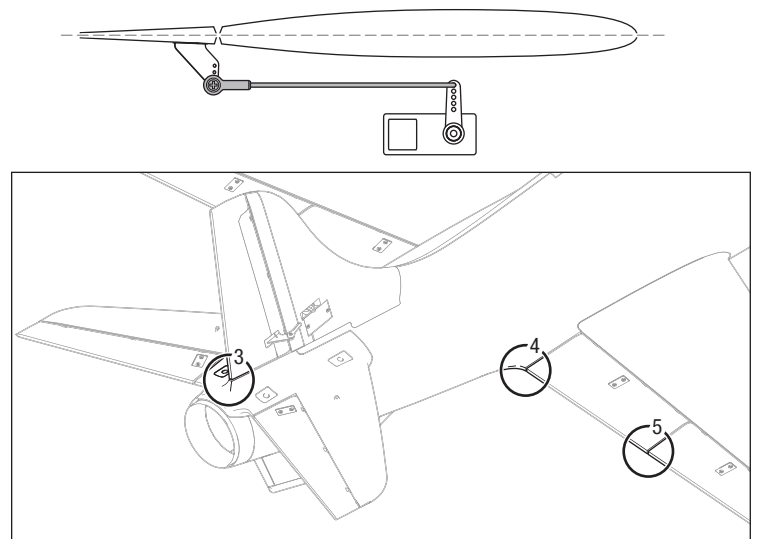

Initial Flight Setup

If this is your first EDF jet model, or if you'd like to further enhance the upright low-speed handling for the first few flights, we recommend putting some upward reflex in the ailerons to add washout to the wing. This will help to further minimize and prevent tip stalls when flying upright at low speeds, especially when landing. Change back at any time before later flights.

To add reflex:

1. Ensure the flaps and ailerons are properly centered.
2. Disconnect the ball link from the aileron control horn.
3. Rotate the ball link out 2 full turns (counter-clockwise).
4. Re-connect the ball link to the aileron control horn.
5. Repeat steps 1-5 for the other aileron.
6. Verify both ailerons have the same amount of reflex, approximately 2mm, when at neutral.

WARNING: Ensure there are still sufficient threads securing the ball link on the pushrods. Un-threading the ball link too far will cause the control surface to fail and in that situation the aircraft may suffer from flutter and/or be uncontrollable in flight.

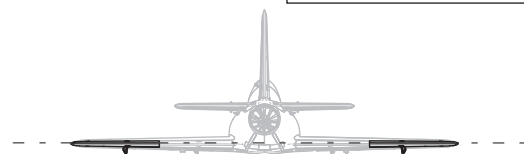
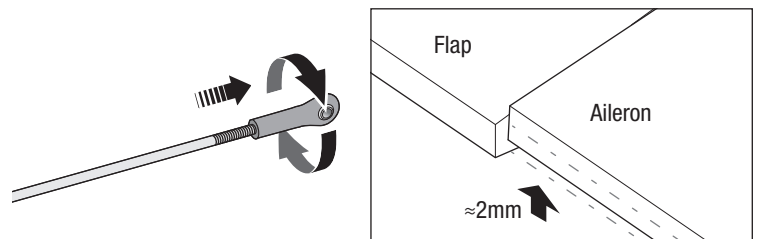

Control Surface Direction

Switch on the transmitter and connect the battery. Use the transmitter to operate the aileron, elevator, and rudder controls. View the aircraft from the rear when checking the control directions.

Ailerons

1. Move the aileron stick to the left. The right aileron should move down and the left aileron up, which will cause the aircraft to bank left.
2. Move the aileron stick to the right. The right aileron should move up and the left aileron down, which will cause the aircraft to bank right.

Elevators

3. Pull the elevator stick back. The elevators should move up, which will cause the aircraft to pitch up.
4. Push the elevator stick forward. The elevators should move down, which will cause the aircraft to pitch down.

Rudder

5. Move the rudder stick to the left. The rudder and the nose wheel should move to the left, which will cause the aircraft to yaw left.
6. Move the rudder stick to the right. The rudder and the nose wheel should move to the right, which will cause the aircraft to yaw right.

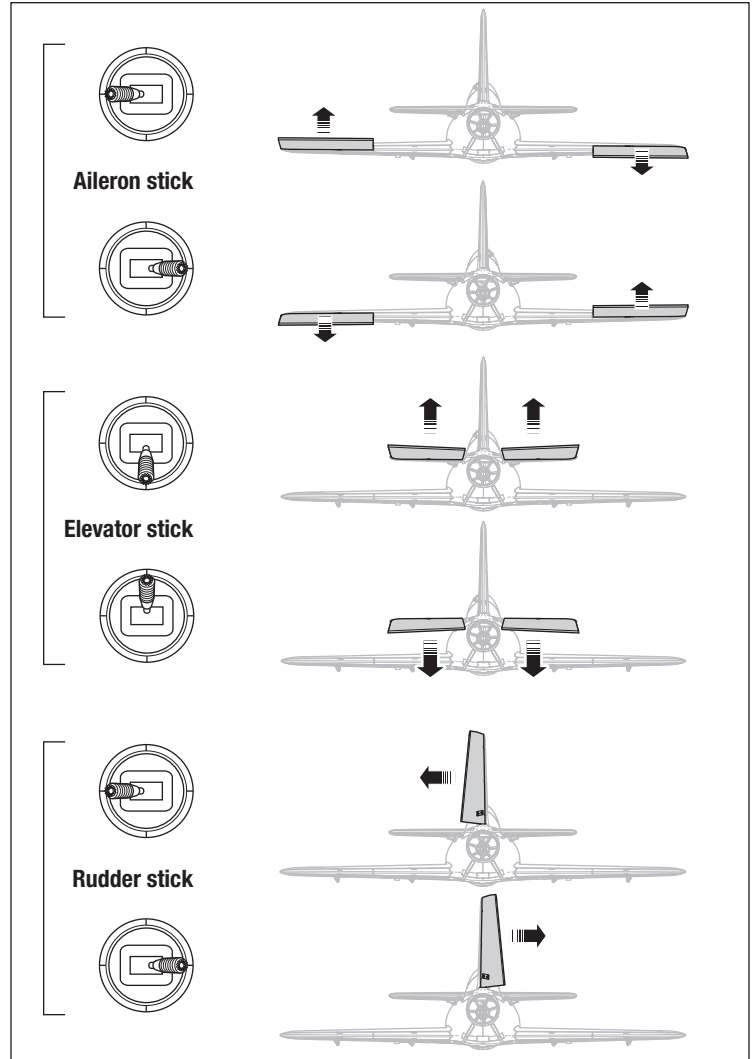

Control Horn and Servo Arm Settings

The table to the right shows the factory settings for the control horns and servo arms. Fly the aircraft at factory settings before making changes.

NOTICE: If control throws are changed from the factory settings, the AR636 gain values may need to be adjusted. Refer to the Spektrum AR636 manual for adjustment of gain values.

After flying, you may choose to adjust the linkage positions for the desired control response. See the table to the right.

Tuning	Horns	Arms
More control throw		
Less control throw		

Factory Setting	Horns	Arms
Elevator		
Rudder		
Aileron		
Flaps		

AS3X Control Direction Test (BNF)









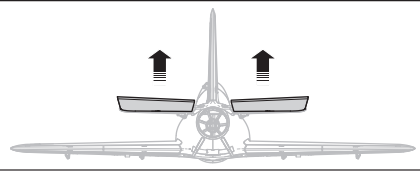

This test ensures that the AS3X® control system is functioning properly. Assemble the aircraft and bind your transmitter to the receiver before performing this test.

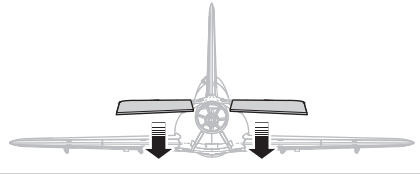
1. Raise the throttle to any setting above 25%, then lower the throttle to activate AS3X technology.

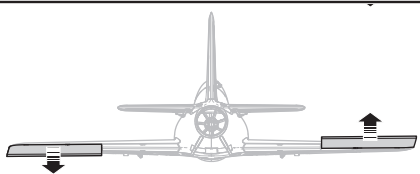
CAUTION: Keep all body parts, hair and loose clothing away from the fan intake, as these items could become entangled.

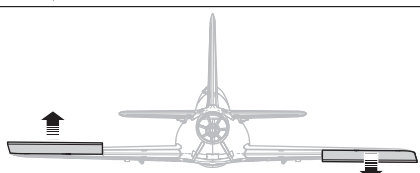
2. Move the entire aircraft as shown and ensure the control surfaces move in the direction indicated in the graphic. If the control surfaces do not respond as shown, do not fly the aircraft. Refer to the receiver manual for more information.

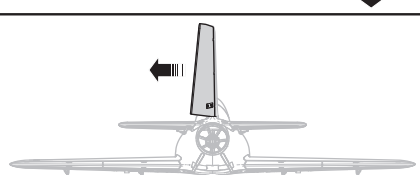
Once the AS3X system is active, control surfaces may move rapidly. This is normal. AS3X remains active until the battery is disconnected.

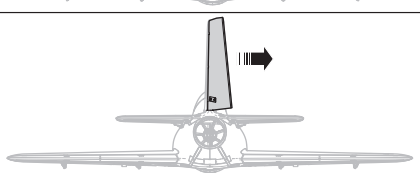
	Aircraft movement	AS3X Reaction
Elevator		
		
Aileron		
		
Rudder		
		

In Flight Trimming (BNF)

During your first flight, trim the aircraft for level flight at 1/2 throttle with flaps up. Make small trim adjustments with your transmitter's trim switches to straighten the aircraft's flight path.

After adjusting the trim, do not touch the control sticks for 3 seconds. This allows the receiver to learn the correct settings to optimize AS3X performance.

Failure to do so could affect flight performance.

3 Seconds

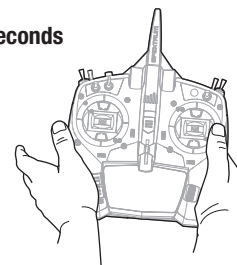

Flying Tips and Repairs

Consult local laws and ordinances before choosing a flying location.

Getting Started

Before you fly, range check the radio system. Refer to your specific transmitter instruction manual for range test information. When you first connect the battery to the airplane AS3X will not be active. After advancing the throttle the first time, the AS3X system will be active and it is normal to see the control surfaces react to aircraft movement. For your first flights set your transmitter timer or a stopwatch to 3.5 minutes. Adjust your timer for longer or shorter flights once you have flown the model.

Takeoff

Face the aircraft into the wind for takeoff. Set your transmitter to low rates and drop the flaps to takeoff position (half position). Flaps are not required, but lowering them makes takeoffs shorter.

Gradually increase the throttle to full, and steer on the ground with rudder as necessary to keep the aircraft rolling straight. Be aware the nose wheel will become more sensitive as speed increases. Leave the elevator at neutral and allow the aircraft to accelerate up to speed on the ground, then pull up gently on the elevator to rotate for takeoff. When airborne, climb to a comfortable altitude, retract the landing gear and then return the flaps to the level position.

Flying

For your first flights climb to a moderate altitude and get comfortable with the aircraft while the battery is fresh. Get a feel for the aircraft's low speed performance with the flaps up and down at a safe altitude (approximately 100 feet or more) before being required to make your first landing attempt. Land the aircraft when the timer expires. If at any time the motor power reduces, land the aircraft immediately to recharge the flight battery. See the Low Voltage Cutoff (LVC) section for more details on maximizing battery health and run time.

Landing

Plan to land the aircraft into the wind when possible. Fly downwind and turn into the wind to begin the approach. Extend the landing gear, lower the throttle and lower the flaps to the landing position (full down position.) Flaps will make the landing approach steeper and slower, and allow for a smoother landing. If there is a significant crosswind, only lower the flaps to the takeoff position (middle position) which will help maintain speed and better directional control during approach.

During the approach and descent, keep the wings level and the aircraft pointed into the wind. The angle of attack (the angle between the aircraft's pitch attitude and the horizon) should remain consistent and slightly nose high during the decent. With the angle of attack maintained during the descent, the speed and descent rate is mostly controlled with small throttle changes. Stay into the throttle to maintain speed and control during decent until the aircraft is ready to flare. As the airplane descends into ground effect, fully lower the throttle, pull the nose up more to bleed off airspeed (flare), and the aircraft will settle on its wheels.

If landing on grass, it is best to hold full up elevator after touchdown and when taxiing to prevent the nose from digging in. Once on the ground, avoid sharp turns until the plane has slowed enough to prevent scraping the wingtips.

SAFE Select Flying Tips

When flying in SAFE Select mode the aircraft will return to level flight any time the aileron and elevator controls are at neutral. Applying aileron or elevator control will cause the airplane to bank, climb or dive, and the amount the stick is moved will determine the attitude the airplane flies. Holding full control will push the aircraft to the pre-determined bank and roll limits but it will not go past those angles.

When flying with SAFE Select it is normal to hold the control stick deflected with moderate aileron input when flying through a turn. To fly smoothly with SAFE Select avoid making frequent control changes and don't attempt to correct for minor deviations. With SAFE Select, holding deliberate control inputs will command the aircraft to fly at a specific angle and the model will make all corrections to maintain that flight attitude.

Return the elevator and aileron controls to neutral before switching from SAFE Select mode to AS3X mode. If you do not neutralize controls when switching into AS3X mode, the control inputs used for SAFE Select mode will be excessive for AS3X mode and the aircraft will react immediately.

NOTICE: If a crash is imminent, reduce the throttle and trim fully. Failure to do so could result in extra damage to the airframe, as well as damage to the ESC and motor.

NOTICE: After any impact, always ensure the receiver is secure in the fuselage. If you replace the receiver, install the new receiver in the same orientation as the original receiver or damage may result.

NOTICE: Crash damage is not covered under warranty.

NOTICE: When you are finished flying, never leave the aircraft in direct sunlight or in a hot, enclosed area such as a car. Doing so can damage the aircraft.

Low Voltage Cutoff (LVC)

When a Li-Po battery is discharged below 3V per cell, it will not hold a charge. The ESC protects the flight battery from over-discharge using Low Voltage Cutoff (LVC). Before the battery charge decreases too much, LVC removes power supplied to the motor. Power to the motor reduces, showing that some battery power is reserved for flight control and safe landing.

Disconnect and remove the Li-Po battery from the aircraft after use to prevent trickle discharge. Charge your Li-Po battery to about half capacity before storage. During storage, make sure the battery charge does not fall below 3V per cell. LVC does not prevent the battery from over-discharge during storage.

NOTICE: Repeated flying to LVC will damage the battery.

Tip: Monitor your aircraft battery's voltage before and after flying by using a Li-Po Cell Voltage Checker (SPMXBC100, sold separately).

Oscillation

For most flight maneuvers the aircraft should fly smoothly and normal, but it is possible in some flight conditions you may see oscillation (the aircraft rocks back and forth on one axis due to overcontrol). If oscillation occurs, refer to the Troubleshooting Guide for more information.

Repairs

Thanks to the EPO foam material in this aircraft, repairs to the foam can be made using virtually any adhesive (hot glue, regular CA, epoxy, etc). When parts are not repairable, see the Replacement Parts List for ordering by item number. For a listing of all replacement and optional parts, refer to the list at the end of this manual.

NOTICE: Use of CA accelerant on your aircraft can damage paint. DO NOT handle the aircraft until accelerant fully dries.

Differences between SAFE Select and AS3X modes

This section is generally accurate but does not take into account flight speed, battery charge status, and many other limiting factors.

- In SAFE Select mode the aircraft will self level when the control stick is neutralized. In AS3X mode the aircraft will continue to fly at its present attitude when the control stick is neutralized.
- In SAFE Select mode holding a small amount of control will result in the model banking or pitching to a moderate angle and remaining at that angle as long as the control stick doesn't move. In AS3X mode holding a small amount of control will result in the model continuing to pitch or roll at a slow rate as long as the control stick doesn't move.
- In SAFE Select mode holding full control will result in the airplane banking or pitching to the predetermined limits and the aircraft will keep flying at that attitude as long as the control stick is fully deflected. In AS3X mode holding full control will result in the aircraft pitching or rolling as fast as possible, and it will continue to rapidly change attitude as long as the control stick is fully deflected.

Post Flight

1. Disconnect the flight battery from the ESC (Required for Safety and battery life).
2. Power OFF the transmitter.
3. Remove the flight battery from the aircraft.
4. Recharge the flight battery.

5. Repair or replace all damaged parts.
6. Store the flight battery apart from the aircraft and monitor the battery charge.
7. Make note of the flight conditions and flight plan results, planning for future flights.

Motor Service

CAUTION: Always disconnect the flight battery before performing motor service.

Disassembly

1. Remove the two screws (A) from the fan unit cover (B) and pull the cover off of the fuselage.
2. Remove the four screws (C) from the fan unit tabs.
3. Pull the fan unit (D) out of the fuselage, take note of the wiring order, and disconnect the motor leads from the ESC.
4. Remove the nose cone screw, nose cone and rotor nut from the rotor adaptor.
5. Remove the rotor by pulling it off the rotor adaptor.
6. Remove the rotor adaptor from the motor shaft.
7. Remove the four 3mm hex head screws that hold the motor in the fan housing

Assembly

Assemble in reverse order.

- Correctly align and connect the motor wire colors with the ESC wires.
- Install the rotor as shown.
- Tighten the nut on the motor adaptor to secure the rotor into place.

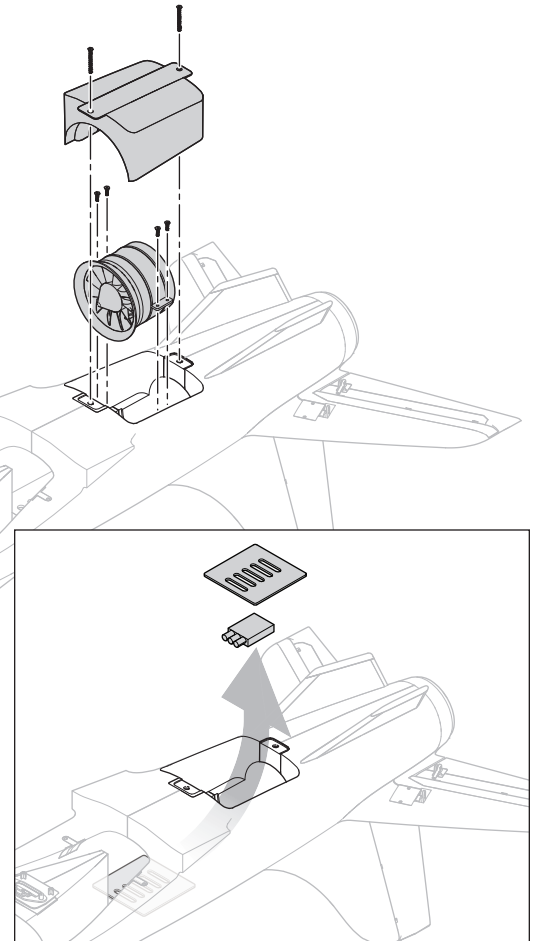
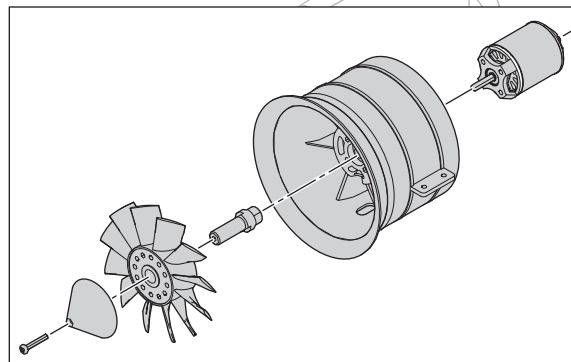

Troubleshooting Guide AS3X

Problem	Possible Cause	Solution
Oscillation	Damaged rotor or nose cone	Replace rotor or nose cone
	Imbalanced rotor	Balance the rotor
	Motor vibration	Replace parts or correctly align fan unit or other parts and tighten fasteners as needed
	Loose receiver	Align and secure receiver in fuselage
	Loose aircraft controls	Tighten or otherwise secure parts (servo, arm, linkage, horn and control surface)
	Worn parts	Replace worn parts (especially rotor, nose cone, or servo)
	Irregular servo movement	Replace servo
Inconsistent flight performance	Trim is not at neutral	If you adjust trim more than 8 clicks, adjust the ball link to remove trim
	Sub-Trim is not at neutral	No Sub-Trim is allowed. Adjust the servo linkage
	Aircraft was not kept immobile for 5 seconds after battery connection	With the throttle stick in lowest position. Disconnect battery, then reconnect battery and keep the aircraft still for 5 seconds
Incorrect response to the AS3X Control Direction Test	Incorrect direction settings in the receiver, which can cause a crash	DO NOT fly. Correct the direction settings (refer to the receiver manual), then fly

Troubleshooting Guide

Problem	Possible Cause	Solution
Aircraft will not respond to throttle but responds to other controls	Throttle not at idle and/or throttle trim too high	Reset controls with throttle stick and throttle trim at lowest setting
	Throttle servo travel is lower than 100%	Make sure throttle servo travel is 100% or greater
	Throttle channel is reversed	Reverse throttle channel on transmitter
	Motor disconnected from ESC	Make sure motor is connected to the ESC
Excessive impeller noise or Excessive vibration	Damaged impeller, nose cone, collet or motor	Replace damaged parts
	Impeller is out of balance	Balance or replace impeller
	Impeller nut is too loose	Tighten the impeller nut
Reduced flight time or aircraft under-powered	Flight battery charge is low	Completely recharge flight battery
	Flight battery damaged	Replace flight battery and follow flight battery instructions
	Flight conditions may be too cold	Make sure battery is not cold before use (Do not apply heat to the battery)
	Battery capacity too low for flight conditions	Replace battery or use a larger capacity battery
Aircraft will not Bind (during binding) to transmitter	Transmitter too near aircraft during binding process	Move powered transmitter a few feet from aircraft, disconnect and reconnect flight battery to aircraft
	Aircraft or transmitter is too close to large metal object, wireless source or another transmitter	Move aircraft and transmitter to another location and attempt binding again
	The bind plug is not installed correctly in the bind port	Install bind plug in bind port and bind the aircraft to the transmitter
	Flight battery/transmitter battery charge is too low	Replace/recharge batteries
	Bind switch or button not held long enough during bind process	Power off transmitter and repeat bind process. Hold transmitter bind button or switch until receiver is bound
Aircraft will not connect (after binding) to transmitter	Transmitter too near aircraft during connecting process	Move powered transmitter a few feet from aircraft, disconnect and reconnect flight battery to aircraft
	Aircraft or transmitter is too close to large metal object, wireless source or another transmitter	Move aircraft and transmitter to another location and attempt connecting again
	Bind plug left installed in bind port	Rebind transmitter to the aircraft and remove the bind plug before cycling power
	Aircraft bound to different model memory (ModelMatch™ radios only)	Select correct model memory on transmitter
	Flight battery/Transmitter battery charge is too low	Replace/recharge batteries
	Transmitter may have been bound to a different aircraft using different DSM protocol	Bind aircraft to transmitter
Control surface does not move	Control surface, control horn, linkage or servo damage	Replace or repair damaged parts and adjust controls
	Wire damaged or connections loose	Do a check of wires and connections, connect or replace as needed
	Transmitter is not bound correctly or the incorrect airplanes was selected	Re-bind or select correct airplanes in transmitter
	Flight battery charge is low	Fully recharge flight battery
	BEC (Battery Elimination Circuit) of the ESC is damaged	Replace ESC
Controls reversed	Transmitter settings are reversed	Perform the Control Direction Test and adjust the controls on transmitter appropriately
Motor power pulses then motor loses power	ESC uses default soft Low Voltage Cutoff (LVC)	Recharge flight battery or replace battery that is no longer performing
	Weather conditions might be too cold	Postpone flight until weather is warmer
	Battery is old, worn out, or damaged	Replace battery
	Battery C rating might be too small	Use recommended battery

Replacement Parts

Part #	Description
EFL7576	Wing Set: HAVOC 80mm Sport EDF Jet
EFL7577	Fuselage: HAVOC 80mm Sport EDF Jet
EFL7578	Horizontal Stabilizers: HAVOC 80mm Sport EDF Jet
EFL7580	Canopy: HAVOC 80mm Sport EDF Jet
EFL7581	Linkage Set: HAVOC 80mm Sport EDF Jet
EFL7582	Wheel Set: HAVOC 80mm Sport EDF Jet
EFL7583	Screw Set: HAVOC 80mm Sport EDF Jet
EFL7584	Ventral Fin Set: HAVOC 80mm EDF Sport Jet
EFL7585	Decal Set: HAVOC 80mm Sport EDF Jet
EFLA10100AEC5	100-Amp Pro Switch-Mode BEC Brushless ESC 270mm Lead
EFLA8012DF	Ducted Fan Unit: 80mm 12 Bladed EDF
EFLA8012R	Ducted Fan Rotor: 80mm 12-Blade EDF
EFLG340	E-Retract Unit: Nose Gear 80mm EDF
EFLG341	E-Retract Unit: Main Gear 80mm EDF
EFLG342	Nose Strut: HAVOC 80mm EDF Sport Jet
EFLG343	Main Strut: HAVOC 80mm EDF Sport Jet
EFLM2000DF	Brushless Inrunner Motor: 3270-2000kV
SPMAR636	AR636 6-Channel AS3X Sport Receiver
SPMSA450	Servo: 13g Analog Metal Gear
SPMSA450R	Servo: 13g Analog Metal Gear Reversed

Optional Parts

Part #	Description
EFLA250	Park Flyer Tool Assortment, 5 pc
SPMA3065	AS3X Programming Cable - USB Interface
SPMBT1000	AS3X Bluetooth Programming Module
SPMXBC100	SMART Battery Checker and Servo Driver (IC3 - use SPMXCA507)
EFLA111	Li-Po Cell Voltage Checker
DYN1405	Li-Po Charge Protection Bag, Large
DYN1400	Li-Po Charge Protection Bag, Small
SPMR12000	iX12 12 Channel Transmitter Only
SPMR6750	DX6 Transmitter Only MD2 G3
SPMR8000	DX8 Transmitter Only MD2
SPMR8100	DX8e 8CH Transmitter Only
SPMR9910	DX9 Black Transmitter Only MD2
SPMX50006S30	22.2V 5000mAh 6S 30C Smart LiPo, IC5
SPMX70006S30	22.2V 7000mAh 6S 30C Smart LiPo, IC5
EFLB50006S40	Thrust VSI 22.2V 5000mAh 6S 40C LiPo Battery: EC5
EFLB44006S30	E-flite 4400mAh 6S 22.2V 30C LiPo, 10AWG: EC5
EFLB50006S30	E-flite 5000mAh 6S 22.2V 30C LiPo, 10AWG: EC5
EFLB50006S50	E-flite 5000mAh 6S 22.2V 50C LiPo, 10AWG: EC5
SPMXC1000	Smart S1200 DC Charger, 1x200W (IC3 - use SPMXCA507)
SPMXC1010	Smart S2100 AC Charger, 2x100W (IC3 - use SPMXCA507)
SPMXCA507	Spektrum IC3 Battery to IC5 Device

Recommended Receivers (PNP)

Part Number	Description
SPMAR620	AR620 6-Channel Sport Air Receiver
	Telemetry Equipped Receivers
SPMAR6600T	AR6600T 6-Channel Air Integrated Telemetry Receiver
SPMAR6270T	AR6270T 6-Channel Carbon Fuse Integrated Telemetry Receiver
SPMAR8010T	AR8010T 8-Channel Air Integrated Telemetry Receiver
SPMAR9030T	AR9030T 9-Channel Air Integrated Telemetry Receiver
	AS3X Equipped Receivers
SPMAR636	AR636 6-Channel AS3X Sport Receiver
	AS3X and Telemetry Equipped Receivers
SPMAR7350	AR7350 7-Channel AS3X Receiver with Integrated Telemetry
SPMAR9350	AR9350 9-Channel AS3X Receiver with Integrated Telemetry
	Telemetry Sensors*
SPMA9574	Aircraft Telemetry Airspeed Indicator
SPMA9589	Aircraft Telemetry Altitude and Variometer Sensor
SPMA9558	Brushless RPM Sensor
SPMA9605	Aircraft Telemetry Flight Pack Battery Energy Sensor
SPMA9587	Aircraft Telemetry GPS Sensor

*Not compatible with BNF, Telemetry receiver required

AMA National Model Aircraft Safety Code

Effective January 1, 2014

A. GENERAL

A model aircraft is a non-human-carrying aircraft capable of sustained flight in the atmosphere. It may not exceed limitations of this code and is intended exclusively for sport, recreation, education and/or competition. All model flights must be conducted in accordance with this safety code and any additional rules specific to the flying site.

1. Model aircraft will not be flown:
 - (a) In a careless or reckless manner.
 - (b) At a location where model aircraft activities are prohibited.
2. Model aircraft pilots will:
 - (a) Yield the right of way to all man carrying aircraft.
 - (b) See and avoid all aircraft and a spotter must be used when appropriate. (AMA Document #540-D.)
 - (c) Not fly higher than approximately 400 feet above ground level within three (3) miles of an airport, without notifying the airport operator.
 - (d) Not interfere with operations and traffic patterns at any airport, heliport or seaplane base except where there is a mixed use agreement.
 - (e) Not exceed a takeoff weight, including fuel, of 55 pounds unless in compliance with the AMA Large Model Aircraft program. (AMA Document 520-A.)
 - (f) Ensure the aircraft is identified with the name and address or AMA number of the owner on the inside or affixed to the outside of the model aircraft. (This does not apply to model aircraft flown indoors).
 - (g) Not operate aircraft with metal-blade propellers or with gaseous boosts except for helicopters operated under the provisions of AMA Document #555.
 - (h) Not operate model aircraft while under the influence of alcohol or while using any drug which could adversely affect the pilot's ability to safely control the model.
 - (i) Not operate model aircraft carrying pyrotechnic devices which explode or burn, or any device which propels a projectile or drops any object that creates a hazard to persons or property.

Exceptions:

 - Free Flight fuses or devices that burn producing smoke and are securely attached to the model aircraft during flight.
 - Rocket motors (using solid propellant) up to a G-series size may be used provided they remain attached to the model during flight. Model rockets may be flown in accordance with the National Model Rocketry Safety Code but may not be launched from model aircraft.
 - Officially designated AMA Air Show Teams (AST) are authorized to use devices and practices as defined within the Team AMA Program Document (AMA Document #718).
 - (j) Not operate a turbine-powered aircraft, unless in compliance with the AMA turbine regulations. (AMA Document #510-A).
3. Model aircraft will not be flown in AMA sanctioned events, air shows or model demonstrations unless:
 - (a) The aircraft, control system and pilot skills have successfully demonstrated all maneuvers intended or anticipated prior to the specific event.
 - (b) An inexperienced pilot is assisted by an experienced pilot.
4. When and where required by rule, helmets must be properly worn and fastened. They must be OSHA, DOT, ANSI, SNELL or NOCSAE approved or comply with comparable standards.

B. RADIO CONTROL

1. All pilots shall avoid flying directly over unprotected people, vessels, vehicles or structures and shall avoid endangerment of life and property of others.
2. A successful radio equipment ground-range check in accordance with manufacturer's recommendations will be completed before the first flight of a new or repaired model aircraft.
3. At all flying sites a safety line(s) must be established in front of which all flying takes place (AMA Document #706.)
 - (a) Only personnel associated with flying the model aircraft are allowed at or in front of the safety line.
 - (b) At air shows or demonstrations, a straight safety line must be established.
 - (c) An area away from the safety line must be maintained for spectators.
 - (d) Intentional flying behind the safety line is prohibited.
4. RC model aircraft must use the radio-control frequencies currently allowed by the Federal Communications Commission (FCC). Only individuals properly licensed by the FCC are authorized to operate equipment on Amateur Band frequencies.
5. RC model aircraft will not operate within three (3) miles of any pre-existing flying site without a frequency-management agreement (AMA Documents #922 and #923.)
6. With the exception of events flown under official AMA Competition Regulations, excluding takeoff and landing, no powered model may be flown outdoors closer than 25 feet to any individual, except for the pilot and the pilot's helper(s) located at the flight line.
7. Under no circumstances may a pilot or other person touch a model aircraft in flight while it is still under power, except to divert it from striking an individual.
8. RC night flying requires a lighting system providing the pilot with a clear view of the model's attitude and orientation at all times. Hand-held illumination systems are inadequate for night flying operations.
9. The pilot of a RC model aircraft shall:
 - (a) Maintain control during the entire flight, maintaining visual contact without enhancement other than by corrective lenses prescribed for the pilot.
 - (b) Fly using the assistance of a camera or First-Person View (FPV) only in accordance with the procedures outlined in AMA Document #550.
 - (c) Fly using the assistance of autopilot or stabilization system only in accordance with the procedures outlined in AMA Document #560.

Please see your local or regional modeling association's guidelines for proper, safe operation of your model aircraft.

Limited Warranty

What this Warranty Covers

Horizon Hobby, LLC, (Horizon) warrants to the original purchaser that the product purchased (the "Product") will be free from defects in materials and workmanship at the date of purchase.

What is Not Covered

This warranty is not transferable and does not cover (i) cosmetic damage, (ii) damage due to acts of God, accident, misuse, abuse, negligence, commercial use, or due to improper use, installation, operation or maintenance, (iii) modification of or to any part of the Product, (iv) attempted service by anyone other than a Horizon Hobby authorized service center, (v) Product not purchased from an authorized Horizon dealer, or (vi) Product not compliant with applicable technical regulations, or (vii) use that violates any applicable laws, rules, or regulations.

OTHER THAN THE EXPRESS WARRANTY ABOVE, HORIZON MAKES NO OTHER WARRANTY OR REPRESENTATION, AND HEREBY DISCLAIMS ANY AND ALL IMPLIED WARRANTIES, INCLUDING, WITHOUT LIMITATION, THE IMPLIED WARRANTIES OF NON-INFRINGEMENT, MERCHANTABILITY AND FITNESS FOR A PARTICULAR PURPOSE. THE PURCHASER ACKNOWLEDGES THAT THEY ALONE HAVE DETERMINED THAT THE PRODUCT WILL SUITABLY MEET THE REQUIREMENTS OF THE PURCHASER'S INTENDED USE.

Purchaser's Remedy

Horizon's sole obligation and purchaser's sole and exclusive remedy shall be that Horizon will, at its option, either (i) service, or (ii) replace, any Product determined by Horizon to be defective. Horizon reserves the right to inspect any and all Product(s) involved in a warranty claim. Service or replacement decisions are at the sole discretion of Horizon. Proof of purchase is required for all warranty claims. SERVICE OR REPLACEMENT AS PROVIDED UNDER THIS WARRANTY IS THE PURCHASER'S SOLE AND EXCLUSIVE REMEDY.

Limitation of Liability

HORIZON SHALL NOT BE LIABLE FOR SPECIAL, INDIRECT, INCIDENTAL OR CONSEQUENTIAL DAMAGES, LOSS OF PROFITS OR PRODUCTION OR COMMERCIAL LOSS IN ANY WAY, REGARDLESS OF WHETHER SUCH CLAIM IS BASED IN CONTRACT, WARRANTY, TORT, NEGLIGENCE, STRICT LIABILITY OR ANY OTHER THEORY OF LIABILITY, EVEN IF HORIZON HAS BEEN ADVISED OF THE POSSIBILITY OF SUCH DAMAGES. Further, in no event shall the liability of Horizon exceed the individual price of the Product on which liability is asserted. As Horizon has no control over use, setup, final assembly, modification or misuse, no liability shall be assumed nor accepted for any resulting damage or injury. By the act of use, setup or assembly, the user accepts all resulting liability. If you as the purchaser or user are not prepared to accept the liability associated with the use of the Product, purchaser is advised to return the Product immediately in new and unused condition to the place of purchase.

Law

These terms are governed by Illinois law (without regard to conflict of law principals). This warranty gives you specific legal rights, and you may also have other rights which vary from state to state. Horizon reserves the right to change or modify this warranty at any time without notice.

WARRANTY SERVICES

Questions, Assistance, and Services

Your local hobby store and/or place of purchase cannot provide warranty support or service. Once assembly, setup or use of the Product has been started, you must contact your local distributor or Horizon directly. This will enable Horizon to better answer your questions and service you in the event that you may need any assistance. For questions or assistance, please visit our website at www.horizonhobby.com, submit a Product Support Inquiry, or call the toll free telephone number referenced in the Warranty and Service Contact Information section to speak with a Product Support representative.

Inspection or Services

If this Product needs to be inspected or serviced and is compliant in the country you live and use the Product in, please use the Horizon Online Service Request submission process found on our website or call Horizon to obtain a Return Merchandise Authorization (RMA) number. Pack the Product securely using a shipping carton. Please note that original boxes may be included, but are not designed to withstand the rigors of shipping without additional protection. Ship via a carrier that provides tracking and insurance for lost or damaged parcels, as Horizon is not responsible for merchandise until it arrives and is accepted at our facility. An Online Service Request is available at http://www.horizonhobby.com/content/_service-center_render-service-center. If you do not have internet access, please contact Horizon Product Support to obtain a RMA number along with instructions for submitting your product for service. When calling Horizon, you will be asked to provide your complete name, street address, email address and phone number where you can be reached during business hours. When sending product into Horizon, please include your RMA number, a list of the included items, and a brief summary of the problem. A copy of your original sales receipt must be included for warranty consideration. Be sure your name, address, and RMA number are clearly written on the outside of the shipping carton.

NOTICE: Do not ship LiPo batteries to Horizon. If you have any issue with a LiPo battery, please contact the appropriate Horizon Product Support office.

Warranty Requirements

For Warranty consideration, you must include your original sales receipt verifying the proof-of-purchase date. Provided warranty conditions have been met, your Product will be serviced or replaced free of charge. Service or replacement decisions are at the sole discretion of Horizon.

Non-Warranty Service

Should your service not be covered by warranty, service will be completed and payment will be required without notification or estimate of the expense unless the expense exceeds 50% of the retail purchase cost.

By submitting the item for service you are agreeing to payment of the service without notification. Service estimates are available upon request. You must include this request with your item submitted for service. Non-warranty 10/15 service estimates will be billed a minimum of ½ hour of labor. In addition you will be billed for return freight. Horizon accepts money orders and cashier's checks, as well as Visa, MasterCard, American Express, and Discover cards. By submitting any item to Horizon for service, you are agreeing to Horizon's Terms and Conditions found on our website http://www.horizonhobby.com/content/_service-center_render-service-center.

ATTENTION: Horizon service is limited to Product compliant in the country of use and ownership. If received, a non-compliant Product will not be serviced. Further, the sender will be responsible for arranging return shipment of the un-serviced Product, through a carrier of the sender's choice and at the sender's expense. Horizon will hold non-compliant Product for a period of 60 days from notification, after which it will be discarded.

10/15

Contact Information

Country of Purchase	Horizon Hobby	Contact Information	Address
United States of America	Horizon Service Center (Repairs and Repair Requests)	servicecenter.horizonhobby.com/RequestForm/	2904 Research Rd Champaign, Illinois, 61822 USA
	Horizon Product Support (Product Technical Assistance)	productsupport@horizonhobby.com 877-504-0233	
	Sales	websales@horizonhobby.com 800-338-4639	
European Union	Horizon Technischer Service	service@horizonhobby.eu	Hanskampring 9 D 22885 Barsbüttel, Germany
	Sales: Horizon Hobby GmbH	+49 (0) 4121 2655 100	

FCC Information

FCC ID: BRWDASRX15

FCC Information

This device complies with part 15 of the FCC rules. Operation is subject to the following two conditions: (1) This device may not cause harmful interference, and (2) this device must accept any interference received, including interference that may cause undesired operation.

 **CAUTION:** Changes or modifications not expressly approved by the party responsible for compliance could void the user's authority to operate the equipment.

This product contains a radio transmitter with wireless technology which has been tested and found to be compliant with the applicable regulations governing a radio transmitter in the 2.400GHz to 2.4835GHz frequency range.

Supplier's Declaration of Conformity

Havoc 80mm EDF BNF Basic with AS3X and SAFE Select

EFL7550

 This device complies with part 15 of the FCC Rules. Operation is subject to the following two conditions: (1) This device may not cause harmful interference, and (2) this device must accept any interference received, including interference that may cause undesired operation.

 **CAUTION:** Changes or modifications not expressly approved by the party responsible for compliance could void the user's authority to operate the equipment.

NOTE: This equipment has been tested and found to comply with the limits for a Class B digital device, pursuant to part 15 of the FCC Rules. These limits are designed to provide reasonable protection against harmful interference in a residential installation. This equipment generates, uses and can radiate radio frequency energy and, if not installed and used in accordance with the instructions, may cause harmful interference to radio communications. However, there is no guarantee that interference will not occur in a particular installation. If this equipment does cause harmful interference to radio or television reception, which can be determined by turning the equipment off and on, the user is encouraged to try to correct the interference by one or more of the following measures:

- Reorient or relocate the receiving antenna.
- Increase the separation between the equipment and receiver.
- Connect the equipment into an outlet on a circuit different from that to which the receiver is connected.
- Consult the dealer or an experienced radio/TV technician for help.

Horizon Hobby, LLC

2904 Research Rd.,

Champaign, IL 61822

Email: compliance@horizonhobby.com

Web: HorizonHobby.com

IC Information

CAN ICES-3 (B)/NMB-3(B)

IC: 6157A-AMRX15

This device complies with Industry Canada licence-exempt RSS standard(s). Operation is subject to the following two conditions: (1) this device may not cause interference, and (2) this device must accept any interference, including interference that may cause undesired operation of the device.

Compliance Information for the European Union

EU Compliance Statement:



EFL7575 Havoc Xe 80mm EDF PNP; Horizon Hobby, LLC hereby declares that this product is in compliance with the essential requirements and other relevant provisions of the EMC Directive.

EFL7550 Havoc Xe 80mm EDF BNF BASIC; Horizon Hobby, LLC hereby declares that this product is in compliance with the essential requirements and other relevant provisions of the RED and EMC Directives.

A copy of the EU Declaration of Conformity is available online at: <http://www.horizonhobby.com/content/support-render-compliance>.

Instructions for disposal of WEEE by users in the European Union



This product must not be disposed of with other waste. Instead, it is the user's responsibility to dispose of their waste equipment by handing it over to a designated collections point for the recycling of waste electrical and electronic equipment. The separate collection and recycling of your waste equipment at the time of disposal will help to conserve natural resources and make sure that it is recycled in a manner that protects human health and the environment. For more information about where you can drop off your waste equipment for recycling, please contact your local city office, your household waste disposal service or where you purchased the product.





© 2020 Horizon Hobby, LLC.

E-flite, AS3X, DSM, DSM2, DSMX, Spektrum Airware, Bind-N-Fly, BNF, the Bind-N-Fly logo, Plug-N-Play, SAFE, the SAFE logo, ModelMatch, and the Horizon Hobby logo are trademarks or registered trademarks of Horizon Hobby, LLC.

The Spektrum trademark is used with permission of Bachmann Industries, Inc.

The Elite Aerosports logo and Havoc Xe name and design are trademarks or registered trademarks of Elite Aerosports, Inc., used under license.

Futaba is a registered trademark of Futaba Denshi Kogyo Kabushiki Kaisha Corporation of Japan.

All other trademarks, service marks and logos are property of their respective owners.

US 8,672,726. US 9,056,667. US 9,753,457. US 10,078,329. US 9,930,567. US 10,419,970.