

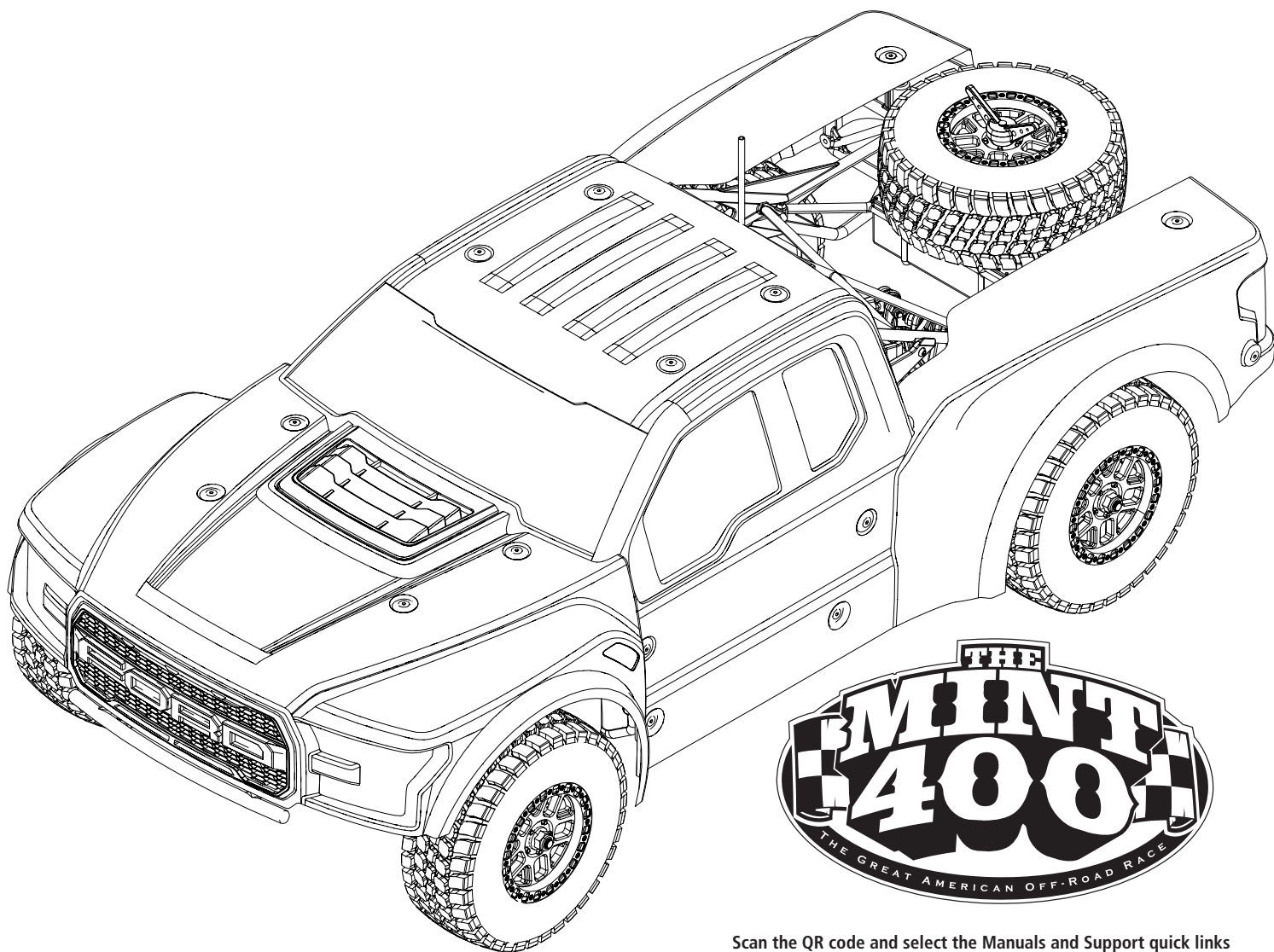

RTR  
READY-TO-RUN



# BAJAREY®



Scan the QR code and select the Manuals and Support quick links from the product page for the most up-to-date manual information. Scannez le code QR et sélectionnez les liens rapides Manuals and Support sur la page du produit pour obtenir les informations les plus récentes sur le manuel.

**INSTRUCTION MANUAL  
MANUEL D'UTILISATION**

Before operating this vehicle, please read all printed materials thoroughly. Horizon Hobby is not responsible for inadvertent errors in this manual.

**HORIZON**  
H O B B Y

## NOTICE

All instructions, warranties and other collateral documents are subject to change at the sole discretion of Horizon Hobby, LLC. For up-to-date product literature, visit [www.horizonhobby.com](http://www.horizonhobby.com) or [www.towerhobbies.com](http://www.towerhobbies.com) and click on the support or resources tab for this product.

## MEANING OF SPECIAL LANGUAGE

The following terms are used throughout the product literature to indicate various levels of potential harm when operating this product:

**WARNING:** Procedures, which if not properly followed, create the probability of property damage, collateral damage, and serious injury OR create a high probability of superficial injury.

**CAUTION:** Procedures, which if not properly followed, create the probability of physical property damage AND a possibility of serious injury.

**NOTICE:** Procedures, which if not properly followed, create a possibility of physical property damage AND a little or no possibility of injury.

 **WARNING:** Read the ENTIRE instruction manual to become familiar with the features of the product before operating. Failure to operate the product correctly can result in damage to the product, personal property and cause serious injury.

This is a sophisticated hobby product. It must be operated with caution and common sense and requires some basic mechanical ability. Failure to operate this Product in a safe and responsible manner could result in injury or damage to the product or other property. This product is not intended for use by children without direct adult supervision. Do not use with incompatible components or alter this product in any way outside of the instructions provided by Horizon Hobby, LLC. This manual contains instructions for safety, operation and maintenance. It is essential to read and follow all the instructions and warnings in the manual, prior to assembly, setup or use, in order to operate correctly and avoid damage or serious injury.

 **WARNING AGAINST COUNTERFEIT PRODUCTS** Always purchase from a Horizon Hobby, LLC authorized dealer to ensure authentic high-quality Spektrum product. Horizon Hobby, LLC disclaims all support and warranty with regards, but not limited to, compatibility and performance of counterfeit products or products claiming compatibility with DSM or Spektrum technology.

**Age Recommendation: Not for children under 14 years. This is not a toy.**

## SAFETY PRECAUTIONS AND WARNINGS

As the user of this product, you are solely responsible for operating in a manner that does not endanger yourself and others or result in damage to the product or property of others.

This model is controlled by a radio signal subject to interference from many sources outside your control. This interference can cause momentary loss of control, so always keep a safe distance in all directions around your model as this margin will help avoid collisions or injury.

- Never operate your model with low transmitter batteries.
- Always operate your model in open spaces away from full-size vehicles, traffic and people.
- Never operate the model in the street or in populated areas for any reason.
- Carefully follow the directions and warnings for this and any optional support equipment (chargers, rechargeable battery packs, etc.) you use.
- Keep all chemicals, small parts and anything electrical out of the reach of children.
- Never lick or place any portion of the model in your mouth as it could cause serious injury or even death.

- Exercise caution when using tools and sharp instruments.
- Take care during maintenance as some parts may have sharp edges.
- Immediately after using your model, do NOT touch equipment such as the motor, electronic speed control and battery, because they generate high temperatures. You may burn yourself seriously touching them.
- Do not put fingers or any objects inside rotating and moving parts, as this may cause damage or serious injury.
- Always turn on your transmitter before you turn on the receiver in the car. Always turn off the receiver before turning your transmitter off.
- Keep the wheels of the model off the ground when checking the operation of the radio equipment.

## WATER-RESISTANT VEHICLE WITH WATERPROOF ELECTRONICS

Your new Horizon Hobby vehicle has been designed and built with a combination of waterproof and water-resistant components to allow you to operate the product in many "wet conditions," including puddles, creeks, wet grass, snow and even rain.

While the entire vehicle is highly water-resistant, it is not completely waterproof and your vehicle should NOT be treated like a submarine. The various electronic components used in the vehicle, such as the Electronic Speed Control (ESC), servo(s) and receiver are waterproof, however, most of the mechanical components are water-resistant and should not be submerged.

Metal parts, including the bearings, hinge pins, screws and nuts, as well as the contacts in the electrical cables, will be susceptible to corrosion if additional maintenance is not performed after running in wet conditions. To maximize the long-term performance of your vehicle and to keep the warranty intact, the procedures described in the "Wet Conditions Maintenance" section below must be performed regularly if you choose to run in wet conditions. If you are not willing to perform the additional care and maintenance required, then you should not operate the vehicle in those conditions.

 **CAUTION:** Failure to exercise caution while using this product and complying with the following precautions could result in product malfunction and/or void the warranty.

### GENERAL PRECAUTIONS

- Read through the wet conditions maintenance procedures and make sure that you have all the tools you will need to properly maintain your vehicle.
- Not all batteries can be used in wet conditions. Consult the battery manufacturer before use. Caution should be taken when using Li-Po batteries in wet conditions.
- Most transmitters are not water-resistant. Consult your transmitter's manual or the manufacturer before operation.
- Never operate your transmitter or vehicle where lightning may be present.
- Do not operate your vehicle where it could come in contact with salt water (ocean water or water on salt-covered roads), contaminated or polluted water. Salt water is very conductive and highly corrosive, so use caution.
- Even minimal water contact can reduce the life of your motor if it has not been certified as water-resistant or waterproof. If the motor becomes excessively wet, apply very light throttle until the water is mostly removed from the motor. Running a wet motor at high speeds may rapidly damage the motor.

- Driving in wet conditions can reduce the life of the motor. The additional resistance of operating in water causes excess strain. Alter the gear ratio by using a smaller pinion or larger spur gear. This will increase torque (and motor life) when running in mud, deeper puddles, or any wet conditions that will increase the load on the motor for an extended period of time.

### WET CONDITIONS MAINTENANCE

- Drain any water that has collected in the tires by spinning them at high speed. With the body removed, place the vehicle upside down and pull full throttle for a few short bursts until the water has been removed.

 **CAUTION:** Always keep hands, fingers, tools and any loose or hanging objects away from rotating parts when performing the above drying technique.

- Remove the battery pack(s) and dry the contacts. If you have an air compressor or a can of compressed air, blow out any water that may be inside the recessed connector housing.
- Remove the tires/wheels from the vehicle and gently rinse the mud and dirt off with a garden hose. Avoid rinsing the bearings and transmission.

**NOTICE:** Never use a pressure washer to clean your vehicle.

- Use an air compressor or a can of compressed air to dry the vehicle and help remove any water that may have gotten into small crevices or corners.
- Spray the bearings, drive train, fasteners and other metal parts with a water-displacing light oil. Do not spray the motor.
- Let the vehicle air dry before you store it. Water (and oil) may continue to drip for a few hours.
- Increase the frequency of disassembly, inspection and lubrication of the following:
  - Front and rear axle hub assembly bearings.
  - All transmission cases, gears and differentials.
  - Motor—clean with an aerosol motor cleaner and re-oil the bushings with lightweight motor oil.

## BOX CONTENTS

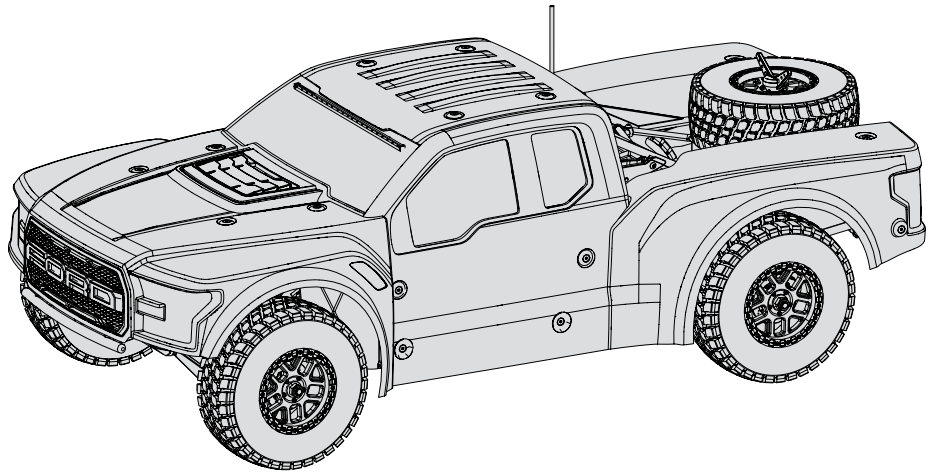
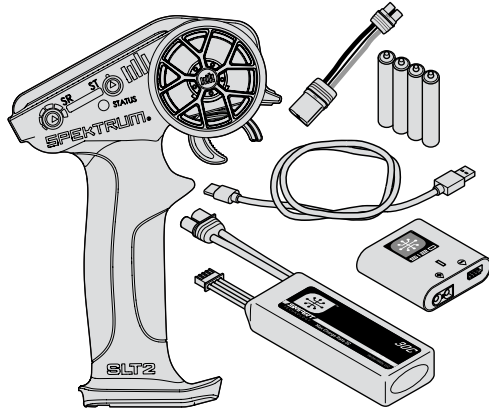

## TABLE OF CONTENTS

SAFETY PRECAUTIONS AND WARNINGS.....	2
WATER-RESISTANT VEHICLE WITH WATERPROOF ELECTRONICS .....	2
BOX CONTENTS.....	3
COMPONENTS.....	3
QUICK START.....	3
CHARGING WARNINGS.....	3
CHARGING THE BATTERY.....	4
INSTALLING THE BATTERY.....	4
SLT2 TRANSMITTER.....	5
BINDING.....	5
CONTROL TEST.....	6
DRIVING PRECAUTIONS.....	6
RUN TIME.....	6
GETTING STARTED.....	6
OPERATION.....	6
SPEKTRUM™ FIRMA™ SMART 130A BRUSHLESS ESC.....	7
SPEKTRUM™ FIRMA™ 3800KV BRUSHLESS MOTOR.....	8
TUNING, ADJUSTING AND MAINTAINING THE VEHICLE.....	8
SERVICE/REPAIR.....	8
TROUBLESHOOTING GUIDE.....	8

LIMITED WARRANTY.....	9
WARRANTY AND SERVICE CONTACT INFORMATION.....	10
FCC INFORMATION.....	10
IC INFORMATION.....	10
COMPLIANCE INFORMATION FOR THE EUROPEAN UNION.....	10
REPLACEMENT PARTS.....	11
OPTIONAL PARTS.....	11
EXPLODED VIEW.....	22–26

## COMPONENTS

- Losi® Ford Raptor Baja Rey® RTR: 1/10-Scale 4WD Desert Truck, The Mint 400 Limited Edition
- Spektrum™ SLT2 2-CH Transmitter (SPMRSLT200)
- Spektrum™ SLR300 3-Channel SLT Receiver Single Protocol (SPMSLR300)
- Spektrum™ Firma 130A Brushless Smart ESC, 2S–4S (SPMXSE1130)
- Spektrum™ Firma 3800Kv 4-Pole BL Motor (SPMXSM2900)
- Spektrum™ S614S 15kg Steel Gear WP Servo 23T (SPMS614S)
- Spektrum™ 7.4V 5000mAh 2S 50C Smart Hardcase LiPo Battery: IC5 (SPMX50002S50H5)
- Spektrum™ S120 USB-C Smart Charger 1x20W (SPMXC1020)
- 4 AA Batteries (for transmitter)

## QUICK START

Please read the entire manual to gain a full understanding of the Ford Raptor Baja Rey Mint 400 vehicle, fine-tuning the setup and performing maintenance.

1. Read the safety precautions found in this manual.
2. Charge the battery. Refer to the included charging warnings and instructions for battery charging information.
3. Install the AA batteries in the transmitter. Only use alkaline or rechargeable batteries.
4. Install a fully charged battery in the vehicle.
5. Power ON the transmitter and then the vehicle. Always power the transmitter ON before the vehicle and power it OFF after the vehicle has been powered OFF.
6. Check the steering and throttle control directions. Verify that the servos are moving in the correct direction.
7. Drive your vehicle.
8. Perform any necessary maintenance.

## CHARGING WARNINGS

**CAUTION:** All instructions and warnings must be followed exactly. Mishandling of Li-Po batteries can result in a fire, personal injury, and/or property damage.

- NEVER LEAVE CHARGING BATTERIES UNATTENDED.
- NEVER CHARGE BATTERIES OVERNIGHT.
- By handling, charging or using the included Li-Po battery, you assume all risks associated with lithium batteries.
- If at any time the battery begins to balloon or swell, discontinue use immediately. If charging or discharging, discontinue and disconnect. Continuing to use, charge or discharge a battery that is ballooning or swelling can result in fire.
- Always store the battery at room temperature in a dry area for best results.
- Always transport or temporarily store the battery in a temperature range of 40–120° F (5–49° C). Do not store battery or aircraft in a car or direct sunlight. If stored in a hot car, the battery can be damaged or even catch fire.
- Always charge batteries away from flammable materials.
- Always inspect the battery before charging and never charge dead or damaged batteries.
- Always disconnect the battery after charging, and let the charger cool between charges.
- Always constantly monitor the temperature of the battery pack while charging.
- ONLY USE A CHARGER SPECIFICALLY DESIGNED TO CHARGE LI-PO BATTERIES. Failure to charge the battery with a compatible charger may cause fire resulting in personal injury and/or property damage.
- Never discharge Li-Po cells to below 3V under load.
- Never cover warning labels with hook and loop strips.
- Never charge batteries outside recommended levels.
- Never attempt to dismantle or alter the charger.
- Never allow minors under the age of 14 to charge battery packs.
- Never charge batteries in extremely hot or cold places (recommended between 40–120° F or 5–49° C) or place in direct sunlight.

## CHARGING THE BATTERY

The recommended battery for the Ford Raptor Baja Rey is an 7.4V, 5000mAh 2S 7.4V 50C Smart Technology LiPo battery with an IC5™ connector (SPMX50002S50H5). If using a different battery, it should be of similar capacity, dimension and weight. Ensure the battery chosen is compatible with an IC5 connector. Follow the chosen battery and battery charger instructions to charge the battery.

### SMART TECHNOLOGY BATTERY AND CHARGER, SPECIFICATIONS AND OPERATION

The included Spektrum S120 Smart Technology battery charger is compatible only with Spektrum Smart 2–3 cell LiPo batteries or 6–7 cell NiMH batteries. It is not compatible with any other battery chemistries or non-SMART batteries.

A USB power source is required for use. A USB-C QC type power source is recommended for the fastest charge times.

S120 Specifications	
Input	USB Type C, power source not included
Input Voltage	5V–12V
Charge Power	18W max (dependant on power supply)
Compatible USB Power Adaptor	5V/1A, 5V/2A, USB Quick Charge (QC) 2.0/3.0
Battery Connector	IC3™ and balance connector
Battery Types	LiPo, NiMH (Spektrum Smart Batteries only)
Cell Count	2–3 cell LiPo, 6–7 cell NiMH
Max Output Voltage	13.05V
Max Output Current	Up to 2A

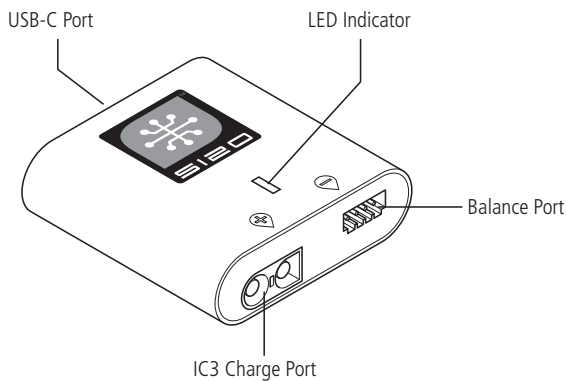

To charge the included battery:

- Using the supplied Type-C USB cable, connect the charger to a USB power source (**not included**).

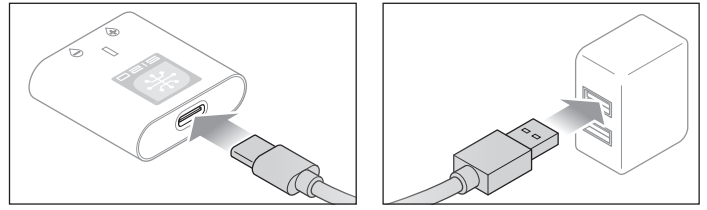

- Connect the Spektrum™ IC3/IC5 adapter (SPMXCA507) (**A**) to the SMART Battery IC5™ connector. Insert the IC3/IC5 adapter (**B**) into the charger IC3 port, and insert the battery balance lead (**C**) into the charger balance port. Both the IC3 and balance connectors must be connected for the charging process to begin. The battery may be disconnected from the charger at any time to stop the charging process.
- Disconnect the IC3 and balance connectors when the charge and balance cycles are complete, as indicated by the LED.
- The LED indicator will glow solid red to indicate a charging error. Follow the operation steps to ensure proper connection is used to charge the battery.

**IMPORTANT:** NiMH batteries do not have a balance connector.

Refer to the LED indicator table for charger status.

**IMPORTANT:** Connecting a non-SMART battery will cause a charge error and the S120 will not recognize or charge the battery.

LED Indicator		
<b>Power On</b>	USB 5V: White LED	
	USB Quick Charge 2.0/3.0: Blue LED	
<b>LiPo: Purple LED</b> <b>NiMH: Yellow LED</b>	Battery Capacity	
	Less Than 25%	Single Flash
	25% – 75%	Double Flash
	76% – 99%	Triple Flash
<b>Charge Complete</b>	Green LED (Solid)	
<b>Error</b>	Red LED (Solid)	

## INSTALLING THE BATTERY

- Ensure the ESC is powered OFF.
- Slide the button to the right to release the battery door.
- Install the fully charged battery in the vehicle.
- Connect the battery to the ESC.
- Close the battery door and slide the battery door button to the left to secure it.
- Power ON the transmitter, then the vehicle.

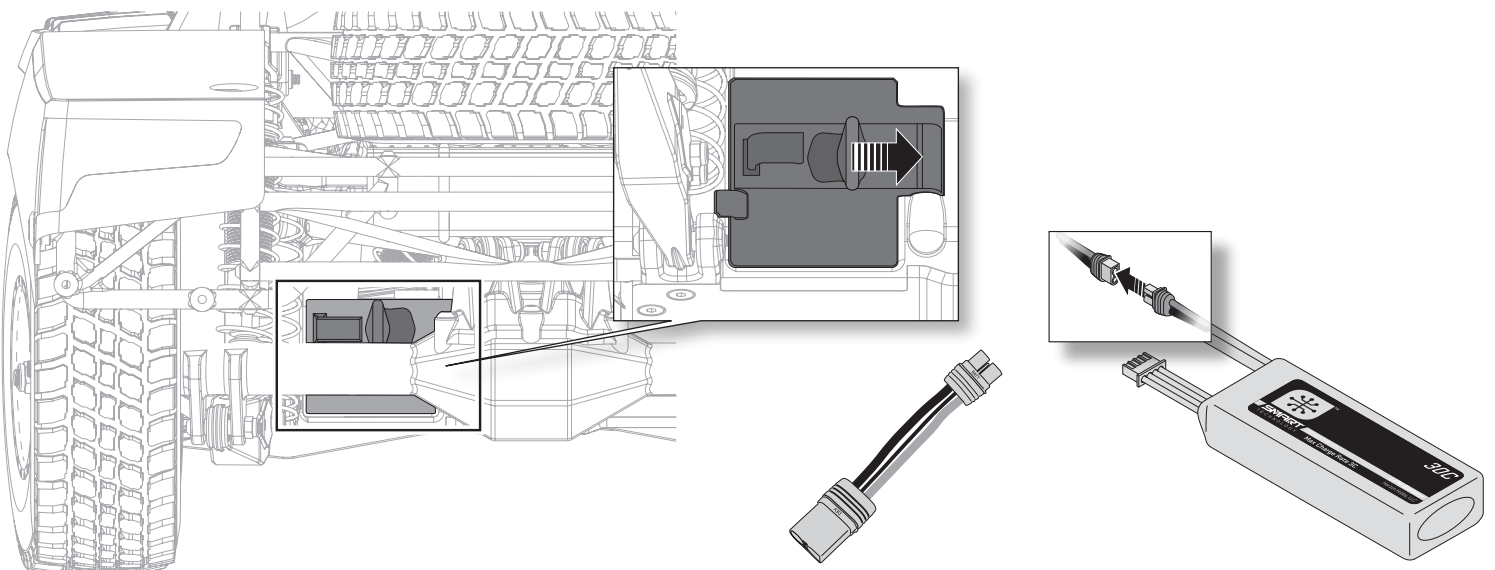

## SLT2 TRANSMITTER

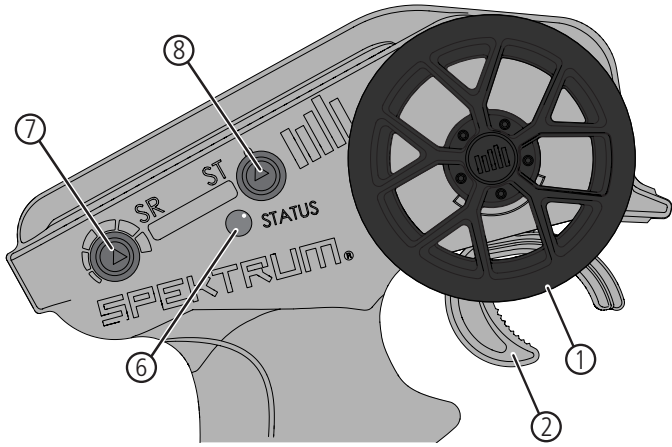

1. **Steering Wheel** Controls direction (left/right) of the model
2. **Throttle Trigger** Controls speed and direction (forward/brake/reverse) of the model
3. **Power Button** Turns the power ON/OFF
4. **Steering (ST-R) Servo Reversing** Reverses the steering channel
5. **Throttle Limit** Limits throttle output to 50/75/100%  
Select 50% or 75% for less experienced drivers or when you are driving the vehicle in a small area
6. **Indicator Lights**
  - **Solid red light**—Indicates radio connectivity and adequate battery power
  - **Flashing red light**—Indicates the battery voltage is critically low. Replace the batteries
7. **Steering Rate** Adjusts the steering end points
8. **Steering Trim** Adjusts the steering center point

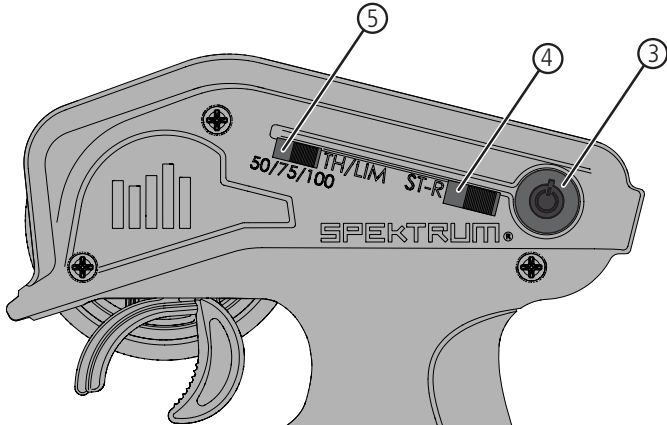

## INSTALLING THE TRANSMITTER BATTERIES

This transmitter requires 4 AA batteries.

1. Remove the battery cover from the transmitter.
2. Install the batteries as shown.
3. Install the battery cover.

**CAUTION:** Never remove the transmitter batteries while the model is powered ON. Loss of model control, damage, or injury may occur.

**CAUTION:** If using rechargeable batteries, charge only rechargeable batteries. Charging non-rechargeable batteries may cause the batteries to burst, resulting in injury to persons and/or damage to property.

**CAUTION:** Risk of explosion if battery is replaced by an incorrect type. Dispose of used batteries according to national regulations.

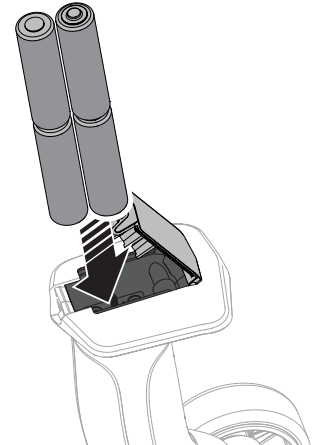

## BINDING

Binding is the process of programming the receiver to recognize the GUID (Globally Unique Identifier) code of a single specific transmitter. **The transmitter and receiver are bound at the factory.** If you need to rebind, follow the instructions below:

1. Insert the bind plug into the bind port of the receiver.
2. Connect a fully charged battery to the ESC.
3. Power on the ESC

4. Power ON the transmitter. The receiver's red LED will turn solid when the bind is successful.
5. Power OFF the ESC to save the settings.
6. Power OFF the transmitter.

You must rebind when binding the receiver to a different transmitter.

**NOTICE:** Do not attempt to bind the transmitter and receiver if there are other compatible transmitters in bind mode within 400 feet. Doing so may result in unexpected binding.

## CONTROL TEST

Perform a control test with the vehicle wheels off the ground. If the wheels rotate after the vehicle is powered ON, adjust the Throttle Trim until they stop. To make the wheels move forward, pull the trigger. To reverse them, wait for the wheels to stop, then push the trigger. When moving forward, the wheels should maintain a straight line without any steering wheel input. If not, adjust the Steering Trim, so the wheels maintain a straight line without having to turn the steering wheel.

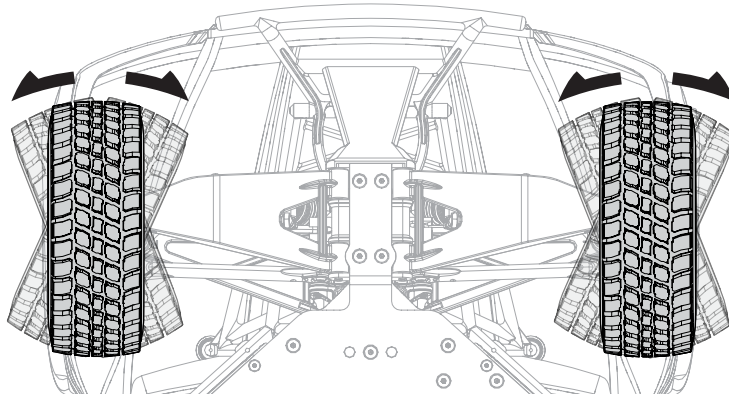
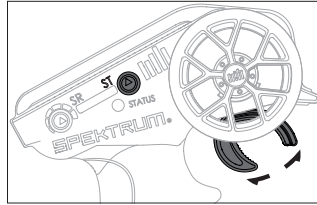

## DRIVING PRECAUTIONS

- Maintain sight of the vehicle at all times.
- Inspect the vehicle for loose wheel hardware.
- Inspect the steering assembly for any loose hardware. Driving the vehicle off-road can cause fasteners to loosen over time.
- Do not drive the vehicle in tall grass. Doing so can damage the vehicle or electronics.
- Stop driving the vehicle when you notice a lack of power. Driving the vehicle when the battery is discharged can cause the receiver to power off. You may lose control of the vehicle.
- Do not apply the throttle in forward or reverse if the vehicle is stuck. Applying throttle in this instance can damage the motor or ESC.
- After driving the vehicle, allow the electronics to cool to ambient temperature before using the next battery pack.

## RUN TIME

The condition of a battery pack is also an important factor in both run time and speed. The battery connectors may become hot during driving. Batteries will lose performance and capacity over time.

Driving the vehicle from a stop to full speed repeatedly will damage the batteries and electronics over time. Sudden acceleration will also lead to shorter run times.

### TO IMPROVE RUN TIMES

- Keep your vehicle clean and well maintained.
- Allow more airflow to the ESC and motor.
- Change the gearing to a lower ratio. A lower ratio lowers the operating temperature of the electronics. Use a smaller pinion gear or larger spur gear to lower the gear ratio.

## GETTING STARTED

1. Power on the transmitter.

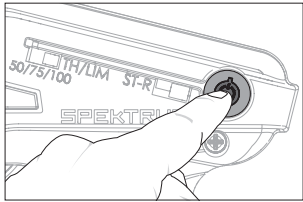

2. Power on the ESC.

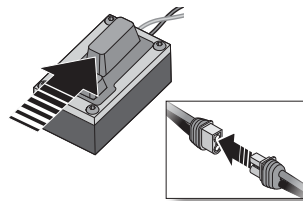

3. Perform a test of the transmitter's control of the vehicle with the vehicle's wheels off the ground.

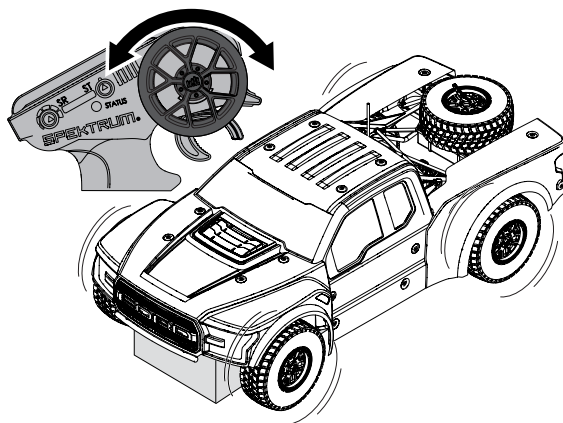

4. Start driving slowly, and, if the vehicle does not go straight, adjust the steering trim dial on the transmitter.

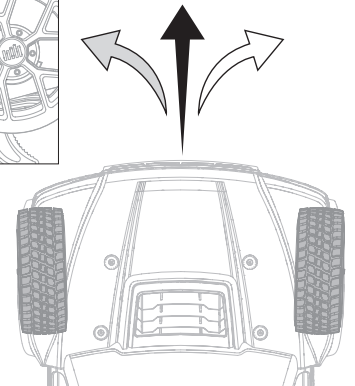
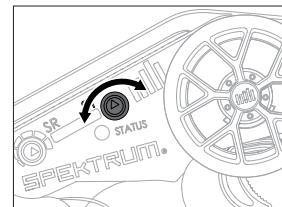

## OPERATION

- **ALWAYS** turn on your transmitter before you turn on the receiver in the vehicle. Always power off the receiver before turning your transmitter off.
- **ALWAYS** operate your vehicle in a wide open area. Operating the vehicle in a small space or indoors can cause overheating at low speeds. Operating at low speed increases heat in the electronic speed control (ESC). Overheating can damage the vehicle and failure may result.

# SPEKTRUM™ FIRMA™ SMART 130A BRUSHLESS ESC (SPMXSE1130)

## SPECIFICATIONS

Type	Sensorless, SMART Throttle Compatible
Output	130A/760A
Function	Forward/Brake–Forward/Brake Reverse
Input Voltage	7.4V–14.8V
BEC Output	6V/4A
Dimensions (LxWxH)	57.5mm x 46mm x 38mm
Weight	154 g

## ESC LED STATUS

- No ESC LEDs will glow when there is no throttle input from the transmitter.
- The red ESC LED glows when there is any throttle input from the transmitter.

## AUDIBLE WARNING TONES

- Input Voltage:** The ESC checks the input voltage when it is powered ON. If a voltage problem is detected, the ESC continuously sounds 2 beeps with a 1 second pause (xx-xx-xx). Power OFF the ESC and ensure the connections are secure and that the battery power is not too low for safe operation.
- Radio Connection:** The ESC checks radio signal input when it is powered ON. If a problem is detected, the ESC continuously sounds 1 beep with a 2 second pause (x-x-x). Power OFF the ESC and ensure the radio system is operating correctly.

**NOTICE:** Always disconnect the battery from the ESC after operating your vehicle. The ESC's switch only controls power to the receiver and servos. The ESC will continue to draw current when connected to the battery, resulting in possible damage to the battery through over discharge.

## ESC CALIBRATION PROCEDURE

Complete the transmitter/receiver binding procedure prior to calibrating the ESC.

- Set the transmitter throttle channel to 100% travel and center the throttle trim.
- Connect a battery to the ESC battery lead.
- Power on the transmitter.
- Press and hold the SET button while turning on the ESC. Release the SET button when the **red** LED begins to flash, indicating the ESC is in calibration mode. The ESC will enter programming mode if the button is held for more than three seconds.

**TIP:** The red LED should be flashing when the ESC enters calibration mode. If the green LED is flashing the ESC has entered programming mode. Power off the ESC and repeat step 4, releasing the SET button when the red LED begins to flash.

- With the transmitter throttle trigger at the neutral position, press and release the ESC SET button. The red LED will stop flashing, the green LED will flash one time and the motor will make a tone to indicate the neutral position has been accepted.
- While holding the throttle trigger at the full throttle position, press and release the ESC SET button. The green LED will flash twice and the motor will make two tones to indicate the full throttle position has been accepted.
- While holding the throttle trigger at the full brake position, press and release the SET button. The green LED will flash three times and the motor will make three tones to indicate the full brake position has been accepted.

The motor will operate normally after calibration is completed.

## ESC FUNCTIONS AND MODES

The ESC includes programming options so you can adjust the way your vehicle performs. Refer to the included programming table to adjust the ESC for your driving conditions.

## PROGRAMMING TABLE

PROGRAMMING ITEMS	PROGRAMMING VALUE								
	1	2	3	4	5	6	7	8	9
1. Running Mode	Forward w/ brake	Forward/Reverse w/ brake	Forward/Reverse						
2. Drag Brake Force	0%	5%	10%	20%	40%	60%	80%	100%	
3. Low Voltage Cutoff	non-protection	2.6V/Cell	2.8V/Cell	3.0V/Cell	3.2V/Cell	3.4V/Cell			
4. Start Mode	Level 1	Level 2	Level 3	Level 4	Level 5	Level 6	Level 7	Level 8	Level 9
5. Max Brake Force	25%	50%	75%	100%	disable				
6. Max Reverse Force	25%	50%	75%	100%					
7. Initial Brake Force	= Drag Brake	0%	20%	40%					
8. Neutral Range	6% (Narrow)	9% (Normal)	12% (Wide)						
9. Timing	0.00°	3.75°	7.50°	11.25°	15.00°	18.75°	22.50°	26.25°	
10. Motor Rotation	Counterclockwise	Clockwise							
11. Li-Po Cells	Auto Calculate	2 Cells	3 Cells	4 Cells	5 Cells	6 Cells			

## DESCRIPTIONS

### 1. Running Mode

- Forward Only with Brake*  
Intended for competition use, this mode allows only forward and brake controls.
- Forward/Reverse with Brake*

This mode is the basic all-around mode, allowing forward, reverse and brake controls. To engage reverse while moving forward, apply the brake until the vehicle has come to a complete stop, release brake, then apply the brake again. While braking or in reverse, engaging the throttle will result in the vehicle immediately accelerating forward.

### 2. Drag Brake Force

Adjusts the amount of brake automatically applied when the throttle is returned to the neutral position. This simulates the engine braking effect of a full-scale vehicle, allowing improved turn-in and your vehicle's general response to controls.

### 3. Low Voltage Cutoff

This function helps to prevent battery over-discharge. The ESC continuously monitors the battery's voltage. If the voltage falls below the voltage threshold for 2 seconds, the output power shuts off and the red LED flashes twice repeatedly.

The cutoff threshold calculation is based on individual Li-Po cell voltage. For Ni-MH batteries, if the voltage battery pack is higher than 9.0V, it will be treated as a 3-cell Li-Po battery pack; if it is lower than 9.0V, it will be treated as a 2-cell Li-Po battery pack. Example: for a 8.0V Ni-MH battery pack used with a 2.6V/cell threshold, it will be treated as a 2-cell Li-Po battery pack and the low-voltage cut-off threshold will be 5.2V (2.6x2=5.2).

### 4. Start Mode (Punch)

Sets the initial throttle punch when the car accelerates. Level 1 gives a very soft initial acceleration and level 4 gives a stronger initial acceleration.

### 5. Max Brake Force

Adjusts the maximum braking force. A higher value provides stronger braking, but can also cause the wheels to lock, resulting in loss of control of the car.

### 6. Max Reverse Force

This parameter adjusts the maximum power when travelling in reverse.

### 7. Initial Brake Force (minimum brake)

Adjusts the minimum amount of braking power when the brakes engage. The default value is equal to the drag brake value. A high value can lock the wheels when the brake is used.

### 8. Neutral Range

Adjusts the throttle sensitivity around the neutral point. A higher value results in the throttle having to be moved more for the vehicle to move forward, backward or brake.

### 9. Timing

Adjusts the motor drive current timing. More timing gives more performance, but can lower efficiency and cause damage to the motor and/or ESC by overload or overheating.

**NOTICE:** Always ensure the motor timing is set correctly. Failure to set the motor timing correctly can result in damage to the motor and ESC. Refer to the manufacturer instructions for recommended timing settings.

### 10. Motor Rotation

Allows you to make this change in the ESC so no wires need to be changed between the ESC and the motor.

### 11. Li-Po Cells

Allows the ESC to automatically detect or manually set the number of cells in your Li-Po battery back.

## ESC PROGRAMMING PROCEDURE

Programming is accomplished using the SET button on the ON/OFF switch\*.

1. Connect a fully charged battery to the ESC.
2. Power on the transmitter.
3. Power on the ESC.
4. Hold the SET button until the green LED flashes. Release the set button to enter programming mode.

**TIP:** To reset all programming items to the default values, press and hold the set button for five seconds

5. Press and release the set button as needed to cycle through the programming items. The number of times the green LED flashes equals the programming item number given in the programming table.
6. When at the desired programming item, press and hold the set button until the red LED flashes to select the item.
7. Press and release the SET button to cycle through the values available for the programming item based on the number of times the LED flashes. Refer to the programming table.
8. Save the setting by pressing and holding the SET button for 3 seconds.
9. Power off the ESC to exit programming mode or to change other programming items.

\*Other programming options include the Spektrum SMART Firma ESC Programming Box (SPMXCA200) and the SmartLink USB updating and programmer application. See SpektrumRC.com for more details about Spektrum SMART Firma ESCs.

## SPEKTRUM™ FIRMA™ 3800KV BRUSHLESS MOTOR

### PRECAUTIONS

- Never touch moving parts.
- Never disassemble while the batteries are installed.
- Always let parts cool before touching.

### GEARING

Your vehicle has been equipped with the optimal gearing for the stock platform. It offers an ideal balance between speed, power and efficiency. Should you decide to customize your vehicle with optional batteries or motors, it may be necessary for you to change the pinion or spur gear.

## TUNING, ADJUSTING AND MAINTAINING THE VEHICLE

- Examine your vehicle on a regular basis.
- Use a brush to remove dirt and dust.
- Look for damage to the suspension arms and other molded parts.
- Re-glue the tires to the wheels, if necessary.
- Use suitable tools to tighten fasteners.
- Make sure the camber and steering linkages are not bent. Replace any bent linkages.
- Adjust the Toe and Camber settings, if necessary.
- Remove the shocks and inspect them for damage. Rebuild the shocks if oil is leaking.
- Inspect electronics and batteries for exposed wires. Repair exposed wires with shrink-wrap or replace the wire.
- Make sure the ESC and receiver are secure on the chassis. Replace the double-sided tape, if necessary.
- Power on your transmitter. If the blue light is flashing, replace the AA batteries in the transmitter.
- Check the spur gear for wear.

## SERVICE/REPAIR

### RADIO/SPEED CONTROL AND MOTOR

If any problems other than those covered in the troubleshooting section arise, please call the appropriate electronics service department. They will be able to give the problem additional specific attention and provide instructions for the solution.

### MAINTENANCE

If any questions other than those covered in the troubleshooting or maintenance sections arise, please call the appropriate Horizon product support department.

### CLEANING

Performance can be hindered if dirt gets in any of the moving suspension parts. Use compressed air, a soft paintbrush, or a toothbrush to remove dust or dirt. Avoid using solvents or chemicals as they can actually wash dirt into the bearings or moving parts, as well as cause damage to the electronics.

## TROUBLESHOOTING GUIDE

PROBLEM	POSSIBLE CAUSE	SOLUTION
Vehicle does not operate	Battery not charged or plugged in	Charge battery/plug in
	ESC switch not "On"	Turn on ESC switch
	Transmitter not "On" or low battery	Turn on/replace batteries
Motor runs but wheels do not rotate	Pinion not meshing with spur gear	Adjust pinion/spur mesh
	Pinion spinning on motor shaft	Tighten pinion gear setscrew on motor shaft flat spot
	Transmission gears stripped	Replace transmission gears
	Drive pin broken	Check and replace drive pin
Steering does not work	Servo plug not in receiver properly	Make sure the steering servo plug is connected to the receiver steering channel, noting proper polarity
	Servo gears or motor damaged	Replace or repair servo
Will not turn one direction	Servo gears damaged	Replace or repair servo
Motor does not run	Motor wire solder joint is damaged	Resolder the motor wire with the proper equipment
	Motor wire broken	Repair or replace as needed
	ESC damaged	Contact Horizon Hobby Product Support
ESC gets hot	Motor over-gear	Use smaller pinion or larger spur gear
	Driveline bound up	Check wheels and transmission for binding
Poor run time and/or sluggish acceleration	Battery pack not fully charged	Recharge battery
	Charger not allowing full charge	Try another charger
	Driveline bound up	Check wheels, transmission for binding
Poor range and/or glitching	Transmitter batteries low	Check and replace
	Vehicle battery low	Recharge battery
	Loose plugs or wires	Check all wire connections and plugs



## LIMITED WARRANTY

**What this Warranty Covers**—Horizon Hobby, LLC, (Horizon) warrants to the original purchaser that the product purchased (the "Product") will be free from defects in materials and workmanship for a period of 2 years from the date of purchase.

**What is Not Covered**—This warranty is not transferable and does not cover (i) cosmetic damage, (ii) damage due to acts of God, accident, misuse, abuse, negligence, commercial use, or due to improper use, installation, operation or maintenance, (iii) modification of or to any part of the Product, (iv) attempted service by anyone other than a Horizon Hobby authorized service center, (v) Product not purchased from an authorized Horizon dealer, or (vi) Product not compliant with applicable technical regulations or (vii) use that violates any applicable laws, rules, or regulations.

OTHER THAN THE EXPRESS WARRANTY ABOVE, HORIZON MAKES NO OTHER WARRANTY OR REPRESENTATION, AND HEREBY DISCLAIMS ANY AND ALL IMPLIED WARRANTIES, INCLUDING, WITHOUT LIMITATION, THE IMPLIED WARRANTIES OF NON-INFRINGEMENT, MERCHANTABILITY AND FITNESS FOR A PARTICULAR PURPOSE. THE PURCHASER ACKNOWLEDGES THAT THEY ALONE HAVE DETERMINED THAT THE PRODUCT WILL SUITABLY MEET THE REQUIREMENTS OF THE PURCHASER'S INTENDED USE.

**Purchaser's Remedy**—Horizon's sole obligation and purchaser's sole and exclusive remedy shall be that Horizon will, at its option, either (i) service, or (ii) replace, any Product determined by Horizon to be defective. Horizon reserves the right to inspect any and all Product(s) involved in a warranty claim. Service or replacement decisions are at the sole discretion of Horizon. Proof of purchase is required for all warranty claims. SERVICE OR REPLACEMENT AS PROVIDED UNDER THIS WARRANTY IS THE PURCHASER'S SOLE AND EXCLUSIVE REMEDY.

**Limitation of Liability**—HORIZON SHALL NOT BE LIABLE FOR SPECIAL, INDIRECT, INCIDENTAL OR CONSEQUENTIAL DAMAGES, LOSS OF PROFITS OR PRODUCTION OR COMMERCIAL LOSS IN ANY WAY, REGARDLESS OF WHETHER SUCH CLAIM IS BASED IN CONTRACT, WARRANTY, TORT, NEGLIGENCE, STRICT LIABILITY OR ANY OTHER THEORY OF LIABILITY, EVEN IF HORIZON HAS BEEN ADVISED OF THE POSSIBILITY OF SUCH DAMAGES. Further, in no event shall the liability of Horizon exceed the individual price of the Product on which liability is asserted. As Horizon has no control over use, setup, final assembly, modification or misuse, no liability shall be assumed nor accepted for any resulting damage or injury. By the act of use, setup or assembly, the user accepts all resulting liability. If you as the purchaser or user are not prepared to accept the liability associated with the use of the Product, purchaser is advised to return the Product immediately in new and unused condition to the place of purchase.

**Law**—These terms are governed by Illinois law (without regard to conflict of law principals). This warranty gives you specific legal rights, and you may also have other rights which vary from state to state. Horizon reserves the right to change or modify this warranty at any time without notice.

### WARRANTY SERVICES

**Questions, Assistance, and Services**—Your local hobby store and/or place of purchase cannot provide warranty support or service. Once assembly, setup or use of the Product has been started, you must contact your local distributor or Horizon directly. This will enable Horizon to better answer your questions and service you in the event that you may need any

assistance. For questions or assistance, please visit our website at [www.horizonhobby.com](http://www.horizonhobby.com), submit a Product Support Inquiry, or call the toll free telephone number referenced in the Warranty and Service Contact Information section to speak with a Product Support representative.

**Inspection or Services**—If this Product needs to be inspected or serviced and is compliant in the country you live and use the Product in, please use the Horizon Online Service Request submission process found on our website or call Horizon to obtain a Return Merchandise Authorization (RMA) number. Pack the Product securely using a shipping carton. Please note that original boxes may be included, but are not designed to withstand the rigors of shipping without additional protection. Ship via a carrier that provides tracking and insurance for lost or damaged parcels, as Horizon is not responsible for merchandise until it arrives and is accepted at our facility. An Online Service Request is available at [http://www.horizonhobby.com/content/\\_service-center\\_render-service-center](http://www.horizonhobby.com/content/_service-center_render-service-center). If you do not have internet access, please contact Horizon Product Support to obtain a RMA number along with instructions for submitting your product for service. When calling Horizon, you will be asked to provide your complete name, street address, email address and phone number where you can be reached during business hours. When sending product into Horizon, please include your RMA number, a list of the included items, and a brief summary of the problem. A copy of your original sales receipt must be included for warranty consideration. Be sure your name, address, and RMA number are clearly written on the outside of the shipping carton.

**NOTICE: Do not ship Li-Po batteries to Horizon. If you have any issue with a Li-Po battery, please contact the appropriate Horizon Product Support office.**

**Warranty Requirements**—For Warranty consideration, you must include your original sales receipt verifying the proof-of-purchase date. Provided warranty conditions have been met, your Product will be serviced or replaced free of charge. Service or replacement decisions are at the sole discretion of Horizon.

**Non-Warranty Service**—Should your service not be covered by warranty, service will be completed and payment will be required without notification or estimate of the expense unless the expense exceeds 50% of the retail purchase cost. By submitting the item for service you are agreeing to payment of the service without notification. Service estimates are available upon request. You must include this request with your item submitted for service. Non-warranty service estimates will be billed a minimum of ½ hour of labor. In addition you will be billed for return freight. Horizon accepts money orders and cashier's checks, as well as Visa, MasterCard, American Express, and Discover cards. By submitting any item to Horizon for service, you are agreeing to Horizon's Terms and Conditions found on our website [http://www.horizonhobby.com/content/service-center\\_render-service-center](http://www.horizonhobby.com/content/service-center_render-service-center).



**ATTENTION: Horizon service is limited to Product compliant in the country of use and ownership. If received, a non-compliant Product will not be serviced. Further, the sender will be responsible for arranging return shipment of the un-serviced Product, through a carrier of the sender's choice and at the sender's expense. Horizon will hold non-compliant Product for a period of 60 days from notification, after which it will be discarded.**

## WARRANTY AND SERVICE CONTACT INFORMATION

Country of Purchase	Horizon Hobby	Contact Information	Address
United States of America	Horizon Service Center (Repairs and Repair Requests)	servicecenter.horizonhobby.com/RequestForm/	2904 Research Road Champaign, Illinois 61822 USA*
	Horizon Product Support (Product Technical Assistance)	productsupport@horizonhobby.com 877-504-0233	
	Sales	websales@horizonhobby.com 800-338-4639	
European Union	Horizon Technischer Service	service@horizonhobby.eu +49 (0) 4121 2655 100	Hanskampring 9 D 22885 Barsbüttel, Germany
	Sales: Horizon Hobby GmbH		

\*For the most up-to-date customer service contact information, please visit: [www.horizonhobby.com/content/service-center-render-service-center](http://www.horizonhobby.com/content/service-center-render-service-center)

## FCC INFORMATION

### FCC ID: BRWSPMSLR300 // BRWSPMSLT200F

This equipment complies with FCC and IC radiation exposure limits set forth for an uncontrolled environment. This equipment should be installed and operated with minimum distance 20cm between the radiator and/or antenna and your body (excluding fingers, hands, wrists, ankles and feet). This transmitter must not be co-located or operating in conjunction with any other antenna or transmitter.

### Supplier's Declaration of Conformity

#### Losi Ford Raptor Baja Rey, 2022 Mint 400 LE (LOS03048)

This device complies with part 15 of the FCC Rules. Operation is subject to the following

**FCC** two conditions: (1) This device may not cause harmful interference, and (2) this device must accept any interference received, including interference that may cause undesired operation.

**CAUTION:** Changes or modifications not expressly approved by the party responsible for compliance could void the user's authority to operate the equipment.

**NOTE:** This equipment has been tested and found to comply with the limits for a Class B digital device, pursuant to part 15 of the FCC Rules. These limits are designed to provide reasonable protection against harmful interference in a residential installation.

This equipment generates, uses and can radiate radio frequency energy and, if not installed and used in accordance with the instructions, may cause harmful interference to radio communications. However, there is no guarantee that interference will not occur in a particular installation. If this equipment does cause harmful interference to radio or television reception, which can be determined by turning the equipment off and on, the user is encouraged to try to correct the interference by one or more of the following measures:

- Reorient or relocate the receiving antenna.
- Increase the separation between the equipment and receiver.
- Connect the equipment into an outlet on a circuit different from that to which the receiver is connected.
- Consult the dealer or an experienced radio/TV technician for help.

Horizon Hobby, LLC  
2904 Research Rd., Champaign, IL 61822  
Email: [compliance@horizonhobby.com](mailto:compliance@horizonhobby.com)  
Web: [HorizonHobby.com](http://HorizonHobby.com)

## IC INFORMATION

### CAN ICES-3 (B)/NMB-3(B)

#### IC: 6157A-SPMSLR300 // 6157A-SPMSLT200F

This device contains license-exempt transmitter(s)/receiver(s) that comply with Innovation, Science, and Economic Development Canada's license-exempt RSS(s). Operation is subject to the following 2 conditions:

1. This device may not cause interference.
2. This device must accept any interference, including interference that may cause undesired operation of the device.

## COMPLIANCE INFORMATION FOR THE EUROPEAN UNION

### EU Compliance Statement:

**Losi Ford Raptor Baja Rey, 2022 Mint 400 LE (LOS03048)**  
Hereby, Horizon Hobby, LLC declares that the device is in compliance with the following: Low Voltage Directive (LVD) 2014/35/EU, 2014/30/EU EMC Directive, Radio Equipment Directive (RED) 2014/53/EU, RoHS 2 Directive 2011/65/EU, RoHS 3 Directive - Amending 2011/65/EU Annex II 2015/863.

The full text of the EU declaration of conformity is available at the following internet address: <https://www.horizonhobby.com/content/support-render-compliance>.

**NOTE:** This product contains batteries that are covered under the 2006/66/EC European Directive, which cannot be disposed of with normal household waste. Please follow local regulations.

### Wireless Frequency Range and Wireless Output Power:

**Transmitter:**  
2410MHz—2480MHz  
23.23dB

### EU Manufacturer of Record:

Horizon Hobby, LLC  
2904 Research Road  
Champaign, IL 61822 USA

### EU Importer of Record:

Horizon Hobby, GmbH  
Hanskampring 9  
22885 Barsbüttel Germany

### WEEE NOTICE:



This appliance is labeled in accordance with European Directive 2012/19/EU concerning waste of electrical and electronic equipment (WEEE). This label indicates that this product should not be disposed of with household waste. It should be deposited at an appropriate facility to enable recovery and recycling.



## Replacement Parts

Part #	Description
LOSA3573	1.0 Module Pitch Pinion, 13T
LOSA6250	Set Screws, 4mm & 5mm (6)
LOSA6937	5x10mm Sealed Ball Bearing (2)
LOSA6940	6x12mm Sealed Ball Bearing (4)
LOSA6956	12x18x4mm Sealed Ball Bearing (2)
LOSA6957	10x15x4mm Bearing
LOS3008	3x6x2.5mm Ball Bearing (2)
LOS43025	Alpine Wheel and Tire Mounted (2)
LOS230010	Roll Cage Sides L&R
LOS230011	Top Bar, X-Bar,Cover & Tire Moun
LOS230012	Front Bar, Rear Body Mount Bar, Bumper, Tower Support
LOS230013	Body Button Base & Top (22)
LOS230020	Interior Set with Helmets, Clear
LOS230066	King Shocks Raptor Body Set
LOS230067	Black Rhino Raptor Body Set
LOS230068	Ford Raptor Body Adaptor Set
LOS230069	Rear Red LED Light Bar
LOS231005	Rear Bulkhead,Fan Panel, Mudguards
LOS231006	Battery Tray,Door, Lock, 2S Spacer
LOS231007	Front Upper Arm/Shock Mount, RR Chassis Brace
LOS231008	Servo Mount, Steering Servo Set Plastic
LOS231010	Chassis Plate & Motor Cover Plate
LOS231011	Center Chassis Brace & Standoffs
LOS231012	Motor Mount
LOS231013	Steering Hardware Set
LOS231058	Front Bumper Set
LOS232002	Center Transmission Housing
LOS232003	Front Gear Box/Bulkhead
LOS232004	HD Diff Housing & Internals: Baja Rey
LOS232005	Rear Driveshaft Set: Baja Rey
LOS232006	Hex, Rotor, Caliper & Pin Set (4)
LOS232007	Center Transmission Gear Set
LOS232008	40T Ring & 14T Pinion Gear FR/RR
LOS232009	Front Axle Set (2)
LOS232010	Center Drive Shaft
LOS232012	Center Outdrive Set
LOS232013	Front Outdrive Set
LOS232014	Rear Axle Shaft Set
LOS232051	Open Rear Diff Gear Set
LOS232072	Axle Housing Set; Rear
LOS233001	Shock Ends, Tops, Piston
LOS233002	FR/RR Shock Body & Collar Set
LOS233003	FR/RR Shock Shaft Set & Hardware
LOS233004	FR/RR Shock Seal & Limiter Set
LOS233005	Front and Rear Spring Set
LOS234002	Shock Tower, Upper/Track Rod Mounts, Rear

## Optional Parts

Part #	Description
LOS43006	Wheels (4)
LOS43011	Desert Claws Tires Soft w/Foam (2)
LOS230009	Body Set, Clear
LOS230026	Sticker Sheet
LOS232011	Rear Diff Locker
LOS321009	Front Bumper & Skid Plate: Baja Rey
LOS330001	LED Roof Light Bar Set
LOS330005	Body Set, Clear
LOS331001	Aluminum Steering Servo Mount
LOS331002	Aluminum Bellcrank Servo Saver Set
LOS331003	Adjustable Turnbuckle Set
LOS331004	Aluminum Rear Upper Link & Space Set

Part #	Description
LOS234003	Trailing Arm, Steering, Upper, Drag Link St
LOS234004	Front Suspension Arm Set Upper/Lower
LOS234005	Steering Spindle Set & Hardware
LOS234006	Front & Rear Sway Bar Links
LOS234007	Front Hinge Pins & Brace Set
LOS234008	7mm Steel Pivot Ball Double Boss (10)
LOS235001	Cap Head Screws M2 x 6mm (10)
LOS235002	Cap Head Screws M2.5 x 10mm (10)
LOS235003	Cap Head Screws M3 x 6mm (10)
LOS235004	Cap Head Screws M3 x 25mm (10)
LOS235005	Button Head Screws M2.5x6mm (10)
LOS235006	Button Head Screws M2.5x 20mm (10)
LOS235007	Button Head Screws M4 x 12mm (10)
LOS235008	Flat Head Screws M2.5 x 5mm (10)
LOS235009	Flat Head Screws M2.5 x 8mm (10)
LOS235010	Flat Head Screws M2.5 x 12mm (10)
LOS235011	Set Screw, M3 x 3mm Cup Point (10)
LOS235012	Set Screw, M4 x 4mm Cup Point (10)
LOS235013	Flat Nut, M3 x 0.5 x 5mm (10)
LOS235014	Lock Nut, M2 x 0.4 x4mm (10)
LOS235015	Lock Nut, Flanged M5 x 0.8 (10)
LOS236002	Differential Shim Kit
LOS236003	Screw Pin Clip Post (10)
LOS255024	Flat Nut, M4 x 0.7 x 7mm (10)
SPMS614	S614 Waterproof Metal Gear Surface Servo, 23T
SPMXSE1130	Firma 130A Brushless Smart ESC, 2S-4S
SPMXSM2900	Firma 3800Kv 4-Pole BL Motor
TLR5909	Button Head Screws, M3 x 0.5mm x 16mm, Stainless, BZ
TLR5910	Button Head Screws, M3 x 0.5mm x 14mm, Stainless, BZ
TLR5911	Button Head Screws, M3 x 0.5mm x 20mm, Stainless, BZ
TLR5913	Button Head Screws, M2.5 x 0.45mm x 12mm, Stainless, BZ
TLR5932	Cap Head Screws, M3 x 0.5mm x 10mm, Stainless, BZ
TLR5933	Cap Head Screws, M3 x 12mm (10)
TLR5934	Cap Head Screws, M3 x 0.5mm x 16mm, Stainless, BZ
TLR5935	Cap Head Screws, M3 x 0.5mm x 20mm, Stainless, BZ
TLR5961	Screw, M3 x 0.5mm x 8mm, Flat Head, Stainless, BZ
TLR5963	Screw, M3 x 0.5mm x 12mm, Flat Head, Stainless, BZ
TLR5964	Screw, M3 x 0.5mm x 16mm, Flat Head, Stainless, BZ
TLR5965	Screw, M3 x 0.5mm x 20mm, Flat Head, Stainless, BZ
TLR6312	Locknut, M2.5x.45 x 5mm (6)
TLR6313	Nut, M3 x 0.5mm x 5.5mm, Nylock, Stainless, Clear Zinc
TLR6352	Washer, 3.2mm x 7mm x 0.5mm, Stainless, Clear Zinc
TLR74006	Silicone Shock Oil, 30wt, 2oz.
TLR245017	M4 Flanged Lock Nuts (10)
TLR255007	Button Head Screws M4 x .07mm x 12mm (10)

Part #	Description
LOS331005	Aluminum Servo Arm, 23T
LOS331006	Aluminum Servo Arm, 24T
LOS331007	Aluminum Servo Arm, 25T
LOS332001	Al Lightened Hex Adapter Set, 12mm x 6mm
LOS332003	Lightened Front Outdrive Set
LOS334001	Aluminum Front Spindle Set
LOS334002	AL Axle Housing Upper Track Rod Mount
LOS334003	Aluminum Upper Lower Bulkhead Track Rod Mounts
LOS334004	Aluminum Rear Shock Tower Set
LOS334005	Aluminum Front Shock Tower
LOS334006	Aluminum Lower Rear Trailing Arm Set



**WWW.LOSI.COM**

©2021 Horizon Hobby, LLC.

Losi, Baja Rey, DSM, DSM2, DSMR, IC3, Dynamite, Fuze, Prophet and the Horizon Hobby logo are trademarks or registered trademarks of Horizon Hobby, LLC. The Spektrum trademark is used with permission of Bachmann Industries, Inc.

Ford Motor Company Trademarks and Trade Dress are used under license to Horizon Hobby.

The Mint 400 logo is property of The Mint 400 Race Corp. and is used with permission.

US 9,930,567. US 10,419,970. US 10,849,013. D829,831. CN201721563463.4. Other patents pending.

Updated 10/21

225835 | LOS03048

