

Leader 480 ARF

Assembly Manual



Notice

All instructions, warranties and other collateral documents are subject to change at the sole discretion of Horizon Hobby, Inc. For up-to-date product literature, visit <http://www.horizonhobby.com> and click on the support tab for this product.

Meaning of Special Language

The following terms are used throughout the product literature to indicate various levels of potential harm when operating this product:

NOTICE: Procedures, which if not properly followed, create a possibility of physical property damage AND a little or no possibility of injury.

CAUTION: Procedures, which if not properly followed, create the probability of physical property damage AND a possibility of serious injury.

WARNING: Procedures, which if not properly followed, create the probability of property damage, collateral damage, and serious injury OR create a high probability of superficial injury.

 **WARNING:** Read the ENTIRE instruction manual to become familiar with the features of the product before operating. Failure to operate the product correctly can result in damage to the product, personal property and cause serious injury.

This is a sophisticated hobby product and NOT a toy. It must be operated with caution and common sense and requires some basic mechanical ability. Failure to operate this Product in a safe and responsible manner could result in injury or damage to the product or other property. This product is not intended for use by children without direct adult supervision. Do not attempt disassembly, use with incompatible components or augment product in any way without the approval of Horizon Hobby, Inc. This manual contains instructions for safety, operation and maintenance. It is essential to read and follow all the instructions and warnings in the manual, prior to assembly, setup or use, in order to operate correctly and avoid damage or serious injury.

Warnings

Read and follow all instructions and safety precautions before use. Improper use can result in fire, serious injury and damage to property.

Age Recommendation: Not for Children under 14 years. This is not a toy.

COMPONENTS

Use only with compatible components. Should any compatibility questions exist please refer to the product instructions, the component instructions or contact Horizon Hobby, Inc.

FLIGHT

Fly only in open areas to ensure safety. It is recommended flying be done at AMA (Academy of Model Aeronautics) approved flying sites. Consult local laws and ordinances before choosing a location to fly your aircraft.

PROPELLER

Keep loose items that can get entangled in the propeller away from the prop, including loose clothing, or other objects such as pencils and screwdrivers. Especially keep your hands away from the propeller as injury can occur.

BATTERIES

Notes on Lithium Polymer Batteries

When misused, lithium polymer batteries are significantly more volatile than alkaline or Ni-Cd/ Ni-MH batteries used in RC applications. Always follow the manufacturer's instructions when using and disposing of any batteries. Mishandling of Li-Po batteries can result in fire causing serious injury and damage.

SMALL PARTS

This kit includes small parts and should not be left unattended near children as choking and serious injury could result.

SAFETY PRECAUTIONS

- Check all control surfaces prior to each takeoff.
- Do not fly your model near spectators, parking areas or any other area that could result in injury to people or damage of property.
- Do not fly during adverse weather conditions. Poor visibility can cause disorientation and loss of control of your aircraft. Strong winds can cause similar problems.
- Do not take chances. If at any time during flight you observe any erratic or abnormal operation, land immediately and do not resume flight until the cause of the problem has been ascertained and corrected. Safety can never be taken lightly.
- Do not fly near power lines.

Table of Contents

Notice	2
Meaning of Special Language	2
Warnings	2
Introduction	3
Important Information Regarding Warranty Information	3
Specifications	3
Using the Manual	3
Contents of Kit/Parts Layout	3
Covering Colors	3
Hardware/Accessory Sizes	4
Recommended Radio Equipment	4
480 Motor Setup	4
Optional Accessories	4
Required Tools and Adhesives	4
Before Starting Assembly	4
Hinging the Ailerons	5
Aileron Servo Installation	6
Rudder and Elevator Servo Installation	8
Nose Gear Installation	10
Receiver Installation	11
Motor and Speed Control Installation	12
Cowling and Spinner Installation	13
Main Landing Gear Installation	15
Wing Installation	16
Stabilizer Installation	17
Vertical Fin Installation	18
Rudder and Elevator Installation	19
Motor Battery Installation	22
Optional Pilot Installation	22
Center of Gravity	23
Control Throws	24
Preflight	24
Range Test Your Radio	25
Flying Your Model	25
Daily Flight Checks	26
Warranty and Repair Policy	26
Warranty Services	27
Compliance Information for the European Union	27
Academy of Model Aeronautics National Model Aircraft Safety Code	28

Introduction

The nimble Leader 480 park flyer is a fun-to-fly sport plane that is ideal for anyone interested in precision aerobatics. Its light wing loading will put any intermediate pilot at ease when flying the slow side of the envelope. But if you really want to wring it out, its symmetrical airfoil and classic pattern plane lines will allow you to fly precision aerobatics with the best of them.

Assembly is so simple, you could easily have it flight-ready in a single evening. Plus, it's small enough you can put it in the backseat or trunk of your car and fly it most anywhere park flyers are allowed.

Important Information Regarding Warranty Information

Please read our Warranty and Liability Limitations section before building this product. If you as the Purchaser or user are not prepared to accept the liability associated with the use of this Product, you are advised to return this Product immediately in new and unused condition to the place of purchase.

Specifications

Wingspan:	43.0 in (1100mm)
Length:	42.4 in (1080mm)
Wing Area:	414 sq in (26.7 sq dm)
Weight with Battery:	39–41 oz (1110–1170 g)
Weight w/o Battery:	33–35 oz (935–990 g)

Using the Manual

This manual is divided into sections to help make assembly easier to understand, and to provide breaks between each major section. In addition, check boxes have been placed next to each step to keep track of its completion. Steps with a single circle (○) are performed once, while steps with two or more circles (○○) indicate the step will require repeating, such as for a right or left wing panel, two servos, etc.

Remember to take your time and follow the directions.

Contents of Kit/Parts Layout

Replacement Parts

EFL300001	Fuselage
EFL300002	Wing Set
EFL300003	Tail Set
EFL300004	Cowling
EFL300005	Landing Gear Strut Set
EFL300006	Canopy Hatch
EFL300007	Main Wheel Set
EFL300008	Wing Tube
EFL300009	Hardware Package
EFL300010	Pushrod Set



Covering Colors

True Red	HANU866
Deep Blue	HANU873
White	HANU870

Hardware/Accessory Sizes

Wheel diameter	2-in (51mm)
Wing bolts	3mm x 10mm socket head cap screw

Recommended Radio Equipment

You will need a minimum 4-channel transmitter, receiver and four servos. You can choose to purchase a complete radio system. If you are using an existing transmitter, just purchase the other required equipment separately. We recommend the crystal-free, interference-free Spektrum™ DX6 2.4GHz DSM® 6-channel system. If using your own transmitter, we recommend the following radio equipment.

If you own the Spektrum DX6i radio, or you are using a different DSM2™ radio, just add the AR6115 6-channel DSMX microlite receiver and four E-flite® DS76 servos.

Complete Radio System

SPM6610	DX6i DSMX 6CH system
---------	----------------------

Or Purchase Separately

SPMAR6115	AR6115 6CH DSMX™ Microlite Receiver
EFLRDS76	DS76 Digital Servo (4)
EFLREX3L	3-inch (76mm) Servo Extension
EFLREX6L	6-inch (152mm) Servo Extension (3)

480 Motor Setup

EFLM1515	Park 480
EFLA1040L	40-Amp Pro Lite SB Brushless ESC
EFLB21003S30	2100mAh 3S 11.1V 30C Li-Po, 12AWG EC3
APC12060E	12 x 6E Electric Propeller

Optional Accessories

EFLA110	Power Meter
EFLC505	Intelligent 1- to 5-Cell Balancing Charger
EFLAEC312	Charge Lead with 12-inch Wire and Jacks, 16AWG
EFLSP175	1 ³ / ₄ -inch Aluminum Spinner with 4mm and 5mm Collets
EFLA156	1/9 Civilian Pilot, Blue with Glasses

Required Tools and Adhesives

Tools & Equipment

Box wrench: 10mm	Felt-tipped pen
Flat file	Hex wrench: 1.5mm, 2.5mm
Low-tack tape	Pin vise
Ruler	Scissors
Side cutter	Square
T-pins	Two-sided tape
String or dental floss	
Drill bit: 1/16-inch (1.5mm), 5/64-inch (2mm)	
Hobby knife with #11 blade	
Phillips screwdriver: #0, #1, #2	

Optional Tools & Equipment

Balancing stand (optional)

Adhesives

Medium CA	PAAPT02
Thin CA	PAAPT08
Threadlock	PAAPT42

Before Starting Assembly

Before beginning the assembly of your model, remove each part from its bag for inspection. Closely inspect the fuselage, wing panels, rudder and stabilizer for damage. If you find any damaged or missing parts, contact the place of purchase.

If you find any wrinkles in the covering, use a heat gun (HAN100) and covering glove (HAN150) or covering iron (HAN101) with a sealing iron sock (HAN141) to remove them. Use caution while working around areas where the colors overlap to prevent separating the colors.



During the course of building your model we suggest you use a soft base for the building surface.

Such things as a foam stand, large piece of bedding foam or a thick bath towel will work well and help protect the model from damage during assembly. This is not shown in the instructions to provide the greatest detail in the photos.

Hinging the Ailerons

Required Parts

Wing panel with aileron (left and right)

Required Tools and Adhesives

Thin CA
Pin vise
T-pins
Drill bit: 1/16-inch (1.5mm)

- 1. Separate the aileron from the wing. Set the five CA hinges aside.



- 2. Use a pin vise and 1/16-inch (1.5mm) drill bit to drill a hole in the center of each hinge slot in the wing to create a tunnel for the CA to wick into. This will allow the CA to penetrate the hinge, creating a better bond between the hinge and surrounding wood.

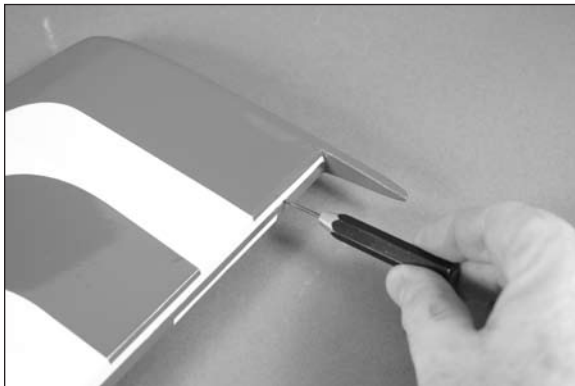

- 3. Place a T-pin in the center of each of the five hinges. This will center the hinges equally in the aileron and wing when they are installed.

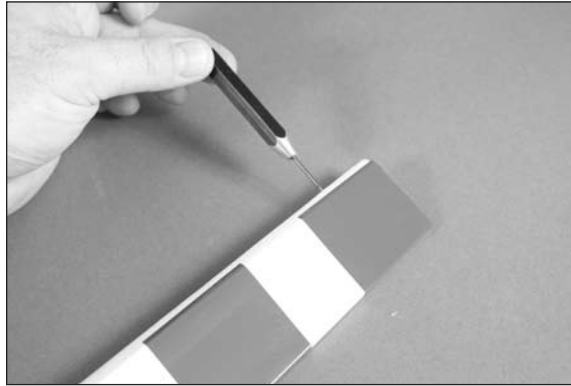

- 4. Insert the hinges in the ailerons. The T-pin will rest on the edge of the aileron bevel.

- 5. Slide the aileron back into position. Center the aileron so the gap at the ends is equal.

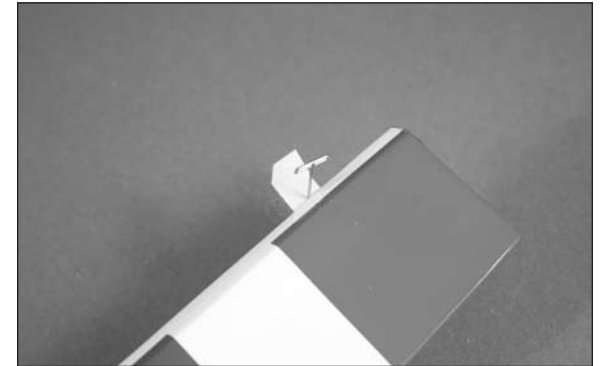

- 6. Saturate each hinge with thin CA. Apply CA to both the top and bottom of the hinge.

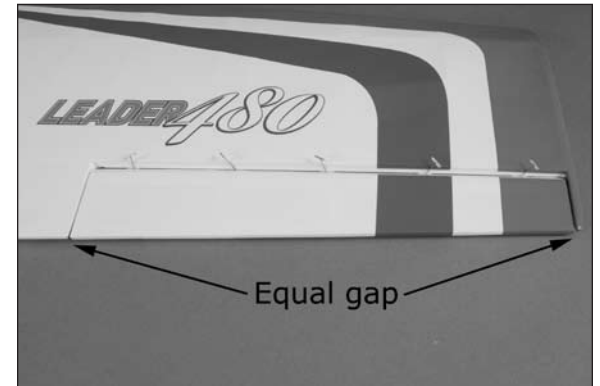

- 7. Saturate each hinge with thin CA. Apply CA to both the top and bottom of the hinge.



E-tips

Do not use CA accelerator when gluing the hinges. The CA must be allowed to soak into the hinge for the best bond between the hinge and surrounding wood.

- ○ 7. Once the CA has cured, gently pull on the control surface and wing to make sure the hinges are glued securely. If not, apply CA to those hinges that are not glued and recheck.



- ○ 8. Move the aileron through its range of motion several times to break in the hinges. This will reduce the initial load on the servo during your first flights.



- ○ 9. Repeat steps 1 through 8 to hinge the remaining aileron.

Aileron Servo Installation

Required Parts

Transmitter Receiver
Receiver battery Servo with hardware (2)
Assembled wing panel (left and right)
Nylon control horn (2)
6-inch (152mm) servo extension (2)
Micro screw-lock connector (2)
1mm x 180mm pushrod (2)

Required Tools and Adhesives

Side cutter Phillips screwdriver: #0, #1
Pin vise Thin CA
Medium CA String or dental floss
Threadlock Ruler
T-pins
Drill bit: 1/16-inch (1.5mm), 5/64-inch (2mm)

- ○ 1. Use side cutters to trim the length of the control horn to 1/4-inch (6mm) as shown.

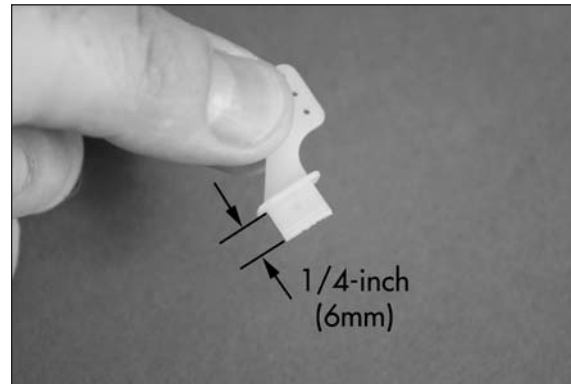

- ○ 2. Use medium CA to glue the control horn in the slot made in the bottom of the aileron.

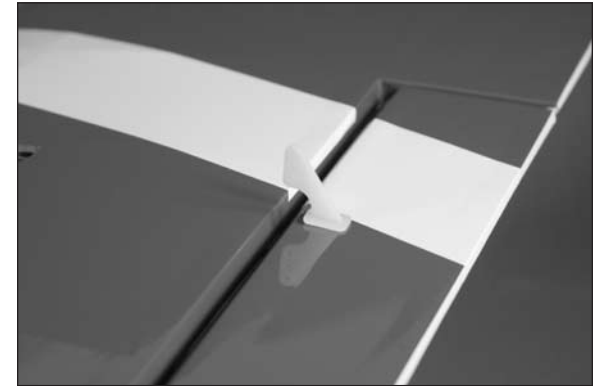

E-tips

Always use threadlock on metal-to-metal fasteners to prevent them from vibrating loose.

- ○ 3. Prepare the servo horn by enlarging the outermost hole in a long single-sided servo horn using a pin vise and 5/64-inch (2mm) drill bit. Secure the micro screw-lock connector to the servo horn using the hardware provided with the connector. Make sure to use threadlock on the nut to prevent it from vibrating loose.



- ○ 4. Connect a 6-inch (152mm) servo extension to the servo lead. Use string of dental floss to secure the leads so they do not accidentally disconnect inside the wing. Use a #0 Phillips screwdriver to remove the servo horn from the servo.

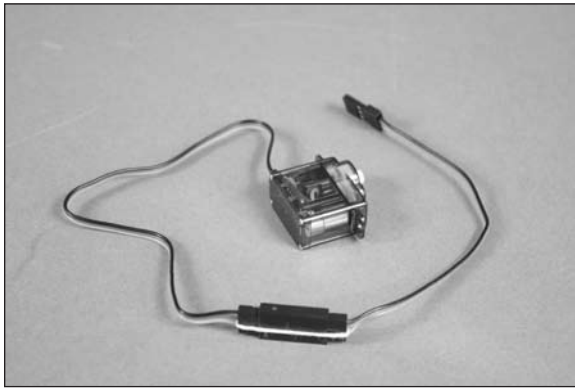

- ○ 5. Insert the servo lead into the wing. Tip the wing tip up and guide the lead out of the wing at the wing root.

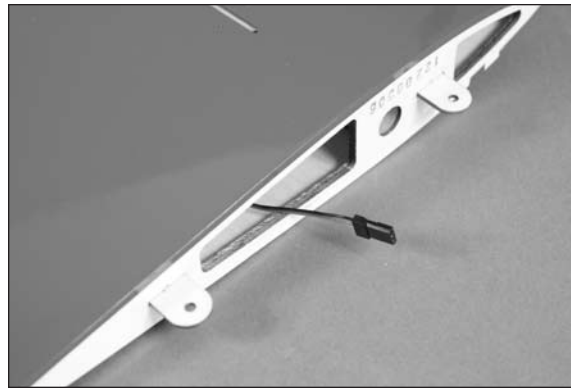

- ○ 6. Use a T-pin to puncture the covering, locating the openings for the servo mounting screws.

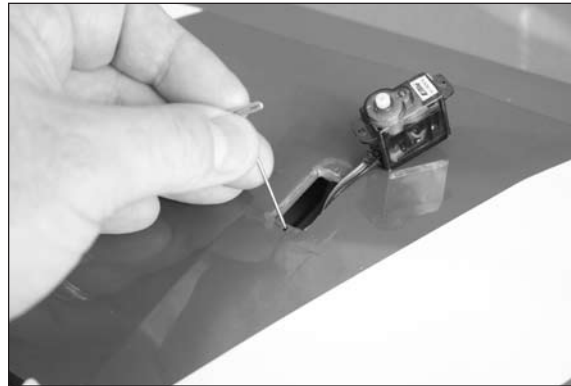

- ○ 7. Use a #1 Phillips screwdriver to thread a servo mounting screw into each of the holes to cut threads in the surrounding wood. Remove the screw before moving to the next step.



- ○ 8. Apply 2-3 drops of thin CA in each of the holes to harden the surrounding wood. This will harden the threads so the screws do not easily strip the surrounding wood.

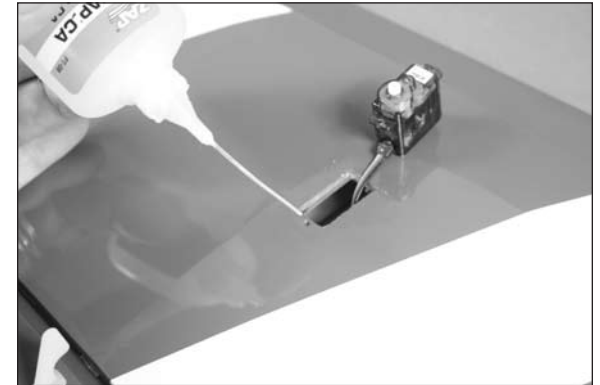

- ○ 9. Secure the servo in the wing using the screws provided with the servo and a #1 Phillips screwdriver. The output shaft of the servo faces toward the aileron as shown. Center the aileron servo using the radio system. Attach the servo horn prepared in step 3 using the screw removed in step 4 and a #0 Phillips screwdriver. Note that the servo horn is parallel to the aileron hinge line.

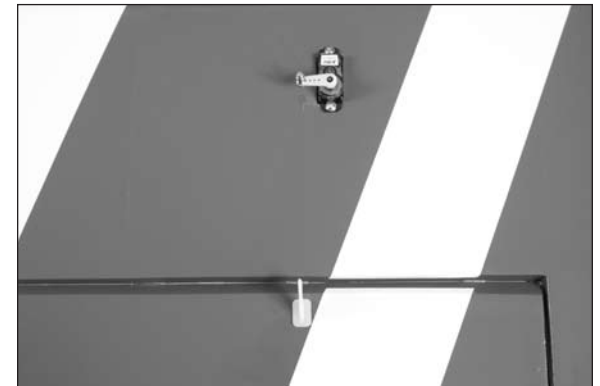

Note: It may be necessary to trim the servo opening for the servo used.

- ○ 10. Pass the Z-bend in the 1mm x 180mm pushrod through the outer hole of the aileron control horn.



E-tips

Always use threadlock on metal-to-metal fasteners to prevent them from vibrating loose.

- ○ 11. The pushrod wire will pass through the hole in the micro screw-lock connector. With the aileron and aileron servo centered, use side cutters to trim the pushrod so it is 1/4 inch (6mm) past the connector as shown. Pass pushrod through micro screw-lock connector. Use a #1 Phillips screwdriver to tighten the screw in the connector to secure the pushrod wire.

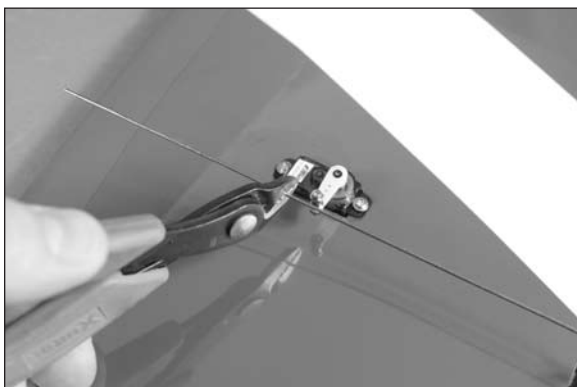

E-tips

Use a small piece of low-tack tape to hold the aileron in position when installing the linkage. Remove the tape once the linkage has been installed.

- 12. Repeat steps 1 through 11 to install the remaining aileron servo and pushrod.



Rudder and Elevator Servo Installation

Required Parts

Fuselage	Servo with hardware (2)
Transmitter	Receiver
Receiver battery	Micro screw-lock connector (3)

Required Tools and Adhesives

Pin vise	Phillips screwdriver: #0, #1
Thin CA	Drill bit: 5/64-inch (2mm)
Threadlock	

- 1. Remove the canopy from the fuselage. Lift the canopy at the front to disconnect the magnets. The rear is held in position using tabs that key into the fuselage.



- 2. Use a #1 Phillips screwdriver to thread a servo mounting screw into each of the holes to cut threads in the surrounding wood. Remove the screw before moving to the next step. Prepare all four mounting holes at this time.

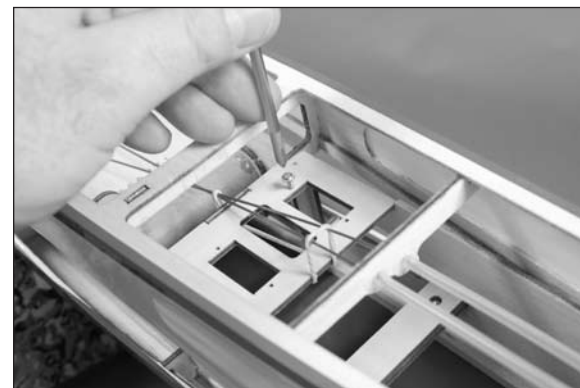

- 3. Apply 2–3 drops of thin CA in each of the holes to harden the surrounding wood. This will harden the threads so the screws do not easily strip the surrounding wood. Prepare all four mounting holes at this time.



- 4. Secure the elevator servo in the fuselage using the screws provided with the servo and a #1 Phillips screwdriver. The output shaft of the servo faces the rear of the fuselage when installed. Remove the servo horn from the servo using a #0 Phillips screwdriver.

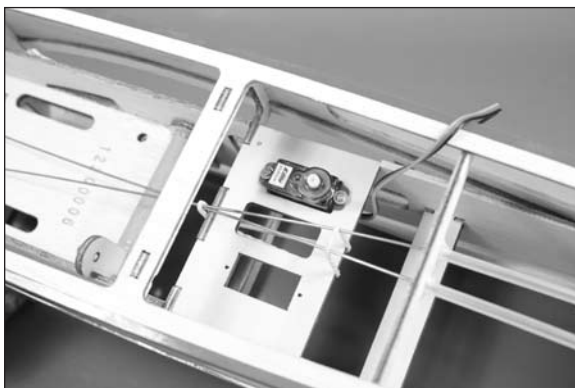

- 5. Repeat step 4 to install the rudder servo in the fuselage. The output of the rudder servo faces the rear of the fuselage when installed.

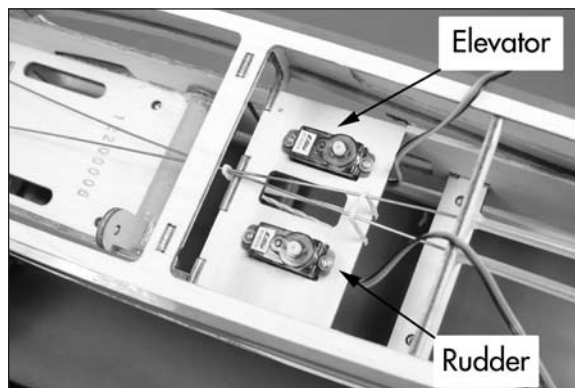

E-tips

Always use threadlock on metal-to-metal fasteners to prevent them from vibrating loose.

- 6. Prepare the rudder and elevator servo horns by enlarging the outermost hole in a long single-sided (elevator) or long double-sided (rudder) servo horn using a pin vise and 5/64-inch (2mm) drill bit. Secure micro screw-lock connectors to the servo horns using the hardware provided with the connectors. Make sure to use threadlock on the nuts to prevent them from vibrating loose.

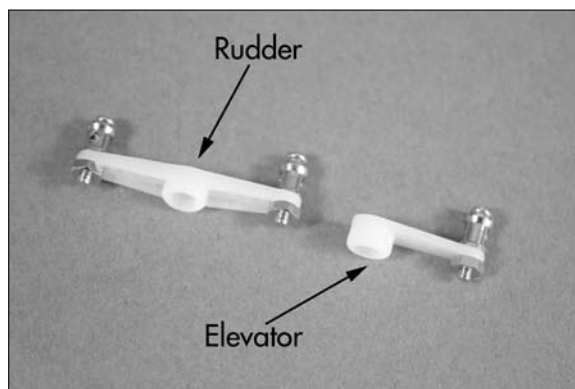

- 7. Use the radio system to center the rudder and elevator servos. Attach the servo horns prepared in step 6 on the rudder and elevator servos using the screw previously removed from the servos and a #0 Phillips screwdriver. Remove the rubber band that holds the pushrod in the fuselage. Pass the pushrod through the connectors and tighten the screws to prevent the pushrod from falling out of the fuselage accidentally.



Nose Gear Installation

Required Parts

Fuselage assembly Nose wheel steering arm
51 mm foam wheel Pre-formed nose gear wire
Transmitter Receiver
Receiver battery
2.5mm wheel collar with setscrew (2)
1 mm x 445mm pushrod with guide tube

Required Tools and Adhesives

Thin CA Phillips screwdriver: #2
Flat file Hex wrench: 1.5mm
Threadlock Side cutter
Sandpaper

- 1. Slide the pushrod guide tube in the fuselage as shown. Use sandpaper to scuff the tube where it passes the mounts in the fuselage so the CA will adhere to the tube. The end of the tube will protrude from the fuselage by 1/32-inch (1mm) use thin CA to glue the tube in the fuselage at the positions shown.

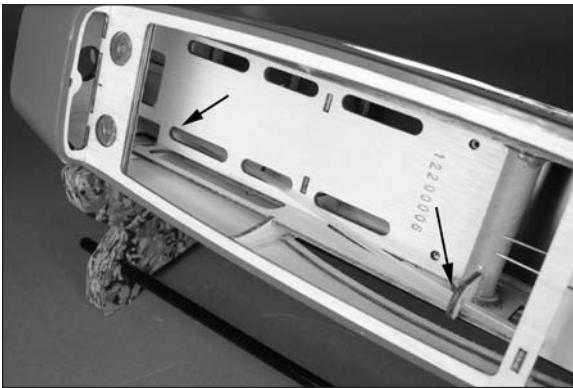

- 2. Insert the Z-bend of the pushrod wire into the nose gear steering arm as shown.

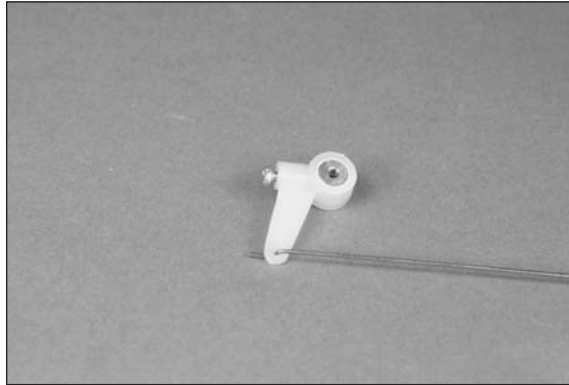

- 3. Slide the pushrod wire through the tube and into the fuselage. Guide the wire through the connector on the rudder servo horn. The steering arm will fit in the bracket as shown.



- 4. Use a flat file to make a 1/4-inch (6mm) wide flat on the bottom of the nose gear wire. This will provide a place to tighten the setscrew when the wheel collar is installed.

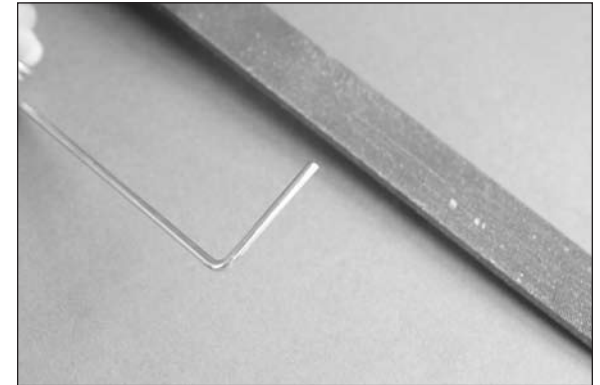

E-tips

Always use threadlock on metal-to-metal fasteners to prevent them from vibrating loose.

- 5. Attach the wheel to the nose gear wire using two 2.5mm wheel collars and setscrews. Tighten the setscrews using a 1.5mm hex wrench.

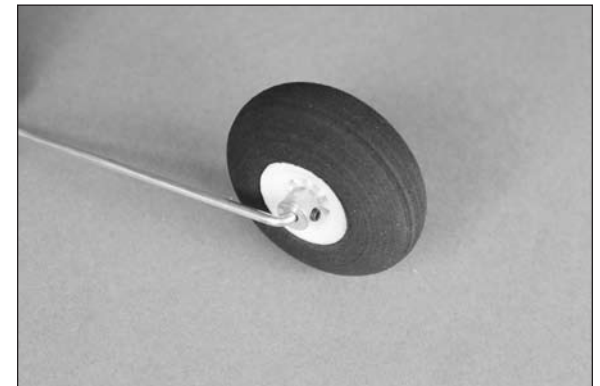

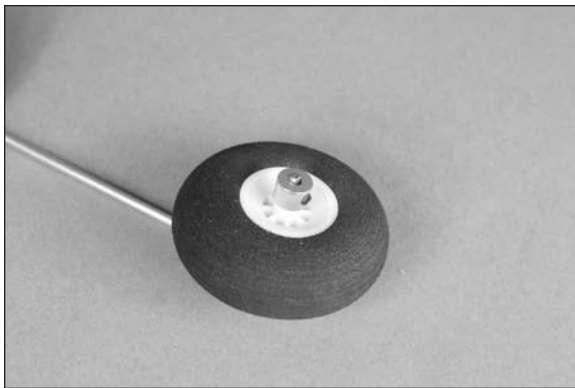

E-tips

Always use threadlock on metal-to-metal fasteners to prevent them from vibrating loose.

- 6. Slide the nose gear wire into the bracket and steering arm. Use a #2 Phillips screwdriver to tighten the screw in the steering arm on the flat of the nose gear wire.



E-tips

Always use threadlock on metal-to-metal fasteners to prevent them from vibrating loose.

- 7. Use the radio system to center the rudder servo. Align the nose gear so the wheel is parallel to the fuselage centerline. Tighten the screw in the pushrod connector to secure the pushrod wire. Use side cutters to trim the excess pushrod wire 1/4-inch (6mm) past the connector as shown.



E-tips

When trimming the airplane to track straight on the ground, the adjustment is made in the linkage for the nose wheel steering, not with the rudder trim. This will cause the rudder to become out of trim in the air.

Receiver Installation

Required Parts

Fuselage assembly Receiver
3-inch (76mm) servo extension
Hook and loop tape (not included)

Required Tools and Adhesives

Scissors

- 1. Plug the rudder and elevator servos into the appropriate ports of the receiver. Also plug a 3-inch (76mm) servo extension into the port for the left aileron.



- 2. Use scissors to cut a piece of hook and loop tape (not included) the size of the receiver. Use the tape to secure the receiver inside the fuselage.



Motor and Speed Control Installation

Required Parts

Fuselage assembly Motor with hardware
Speed control 3mm washer (4)
3mm lock washer (4)
Two-sided tape (not included)
6-inch (152mm) servo extension
3mm x 30mm socket head cap screw (4)
Aluminum motor standoff, 18mm (4)

Required Tools and Adhesives

Phillips screwdriver: #1
Hex wrench: 2.5mm

Etips

Always use threadlock on metal-to-metal fasteners to prevent them from vibrating loose.

- 1. Attach the X-mount to the motor using the hardware included with the motor and a #1 Phillips screwdriver



- 2. Secure the motor to the firewall using the four 18mm aluminum motor standoffs, four 3mm x 30mm socket head cap screws, four 3mm washers and four 3mm lock washers. Use a 2.5mm hex wrench to tighten the screws. Make sure to use threadlock on these screws as well to prevent them from vibrating loose.



- 3. Place the speed control in the fuselage. It will fit between the side and sub-side of the fuselage as shown. Pass the leads for the motor through the opening at the top of the firewall as shown in the following step. Use two-sided tape to secure the speed control in the fuselage.



Etips

Matching the colors between the ESC and motor when they are connected results in the correct motor direction if using all E-flite components.

- 4. Connect the leads from the motor to the speed control. Once connected, tuck the leads back in the fuselage to prevent them from interfering with the operation of the motor.

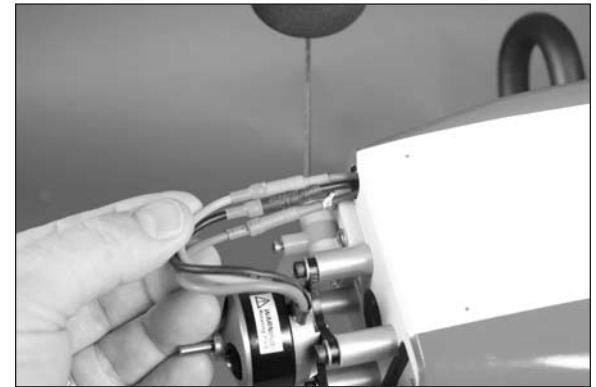

- 5. Plug the lead from the speed control into the throttle port of the receiver at this time.

Cowling and Spinner Installation

Required Parts

Fuselage assembly Spinner (optional)
Cowling Propeller
#0 Phillips head wood screw (4)

Required Tools and Adhesives

Low-tack tape Pin vise
Thin CA Phillips screwdriver: #1
Box wrench: 10mm
Hex wrench: 2.5mm
Drill bit: 1/16-inch (1.5mm), 5/64-inch (2mm)

Etips

Always balance your propeller. An unbalanced propeller can cause vibrations to be transmitted into the airframe, which could damage the airframe or other components as well as produce unwanted flight characteristics.

Etips

We recommend using the optional spinner to enhance the looks of your model.

- 1. Install the propeller on the spinner assembly. Do not tighten the propeller nut so the assembly can be placed on the motor shaft.



- 2. Slide the cowling on the fuselage.



Etips

Place a piece of 3/32-inch (2.5mm) thick two-sided tape (not included) between the cowling and spinner backplate to set the spacing. This will also hold the cowling in position at the front so it can be positioned easily at the rear to match the paint lines from the cowl to the fuselage.

- 3. Slide the propeller/spinner on the motor shaft. Position the cowl so there is a gap of 3/32-inch (2mm) between the spinner backplate and cowl.



- 4. Use low-tack tape to hold the cowling in position for the following step. Make sure the propeller can rotate without the backplate rubbing against the cowling.



- 5. Measure 3/16-inch (5mm) forward of the edge of the cowl, and in 3/16-inch (5mm) from the paint lines on the cowl. Use a pin vise with a 1/16-inch (1.5mm) drill bit to drill four holes through the cowling and fuselage side for the cowl mounting screws.

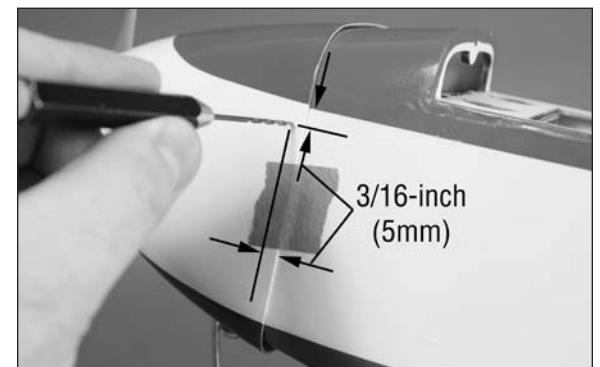
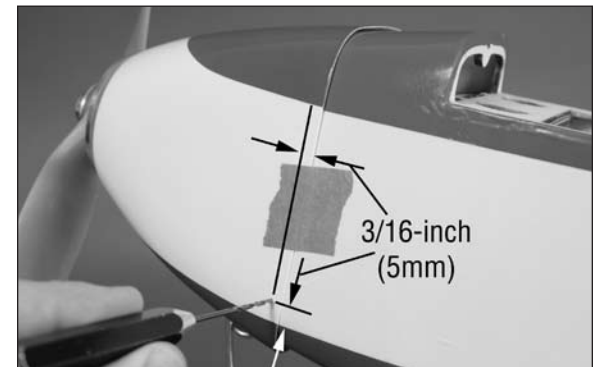

- 6. Remove the propeller and cowl from the fuselage. Enlarge the holes in the cowl using a pin vise and 5/64-inch (2mm) drill bit.

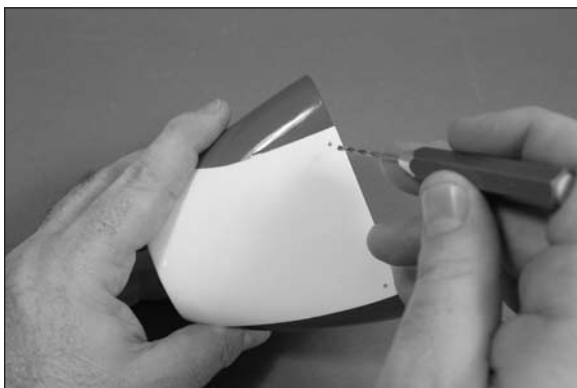

- 7. Use a #1 Phillips screwdriver to thread a #0 Phillips head wood screw into each of the holes to cut threads in the surrounding wood. Remove the screw before moving to the next step. Prepare all four mounting holes at this time.

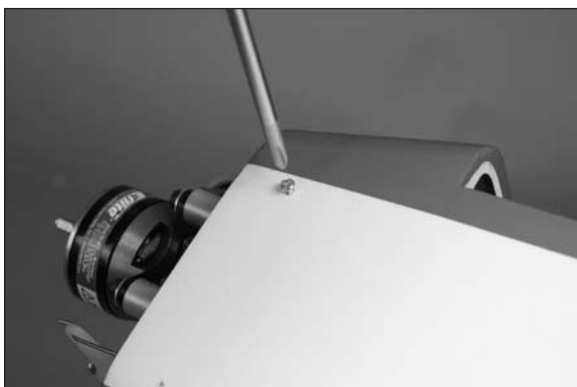

- 8. Apply 2–3 drops of thin CA in each of the holes to harden the surrounding wood. This will harden the threads so the screws do not easily strip the surrounding wood. Prepare all four mounting holes at this time.



- 9. Once the CA has cured, use four #0 Phillips head wood screws and a #1 Phillips screwdriver to secure the cowl to the fuselage.

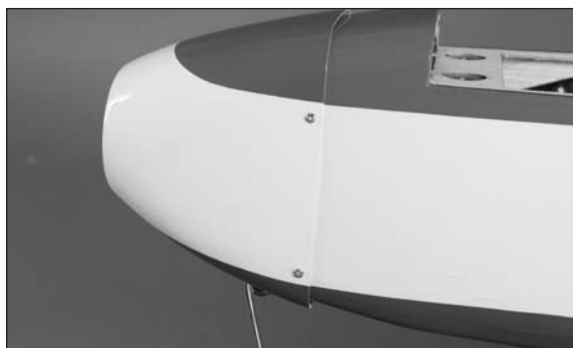

- 10. Slide the propeller/spinner on the motor shaft. Use a 10mm box wrench to tighten the nut securing the assembly to the motor shaft.



- 11. Place the spinner cone on the propeller. Use the screw included with the spinner assembly and a 2.5mm hex wrench to secure the cone in position.



Main Landing Gear Installation

Required Parts

Wing panel assembly (left and right)
Pre-bent main landing gear (2)
#2 Phillips head wood screw (8)
Nylon landing gear strap (4)
51mm foam wheel (2)
2.5mm wheel collar with setscrew (4)

Required Tools and Adhesives

Flat file Hex wrench: 1.5mm
Threadlock Phillips screwdriver: #2
Thin CA

- 1. Use a #1 Phillips screwdriver to thread a #0 Phillips head wood screw into each of the holes to cut threads in the surrounding wood. Remove the screw before moving to the next step. Prepare all four mounting holes at this time.

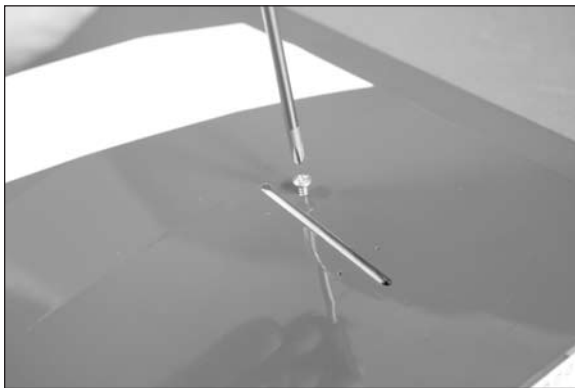

- 2. Apply 2–3 drops of thin CA in each of the holes to harden the surrounding wood. This will harden the threads so the screws do not easily strip the surrounding wood. Prepare all four mounting holes at this time.

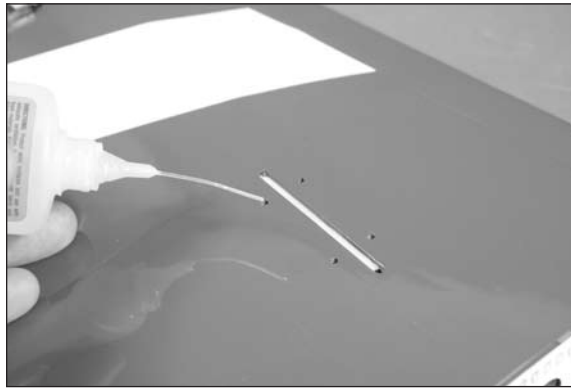

- 3. Use a flat file to make a 1/4-inch (6mm) wide flat area on the bottom of the landing gear wire. This will provide a place to tighten the setscrew when the wheel collar is installed.

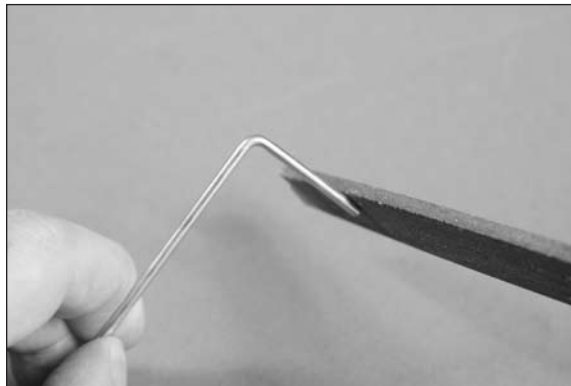

- 4. Insert the landing gear wire into the wing. It will rest flush with the wing as shown in the second photo when installed.

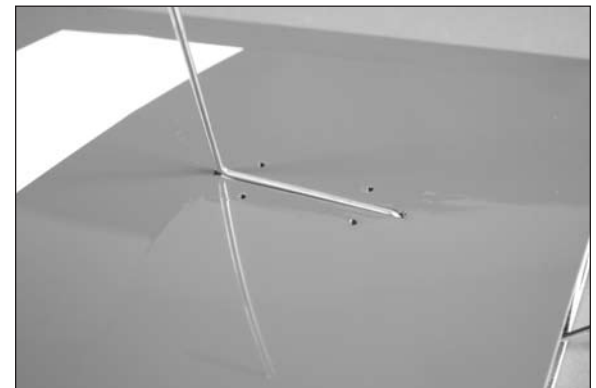

- 5. Use two nylon landing gear straps and four #2 Phillips head wood screws to secure the main landing gear to the wing.

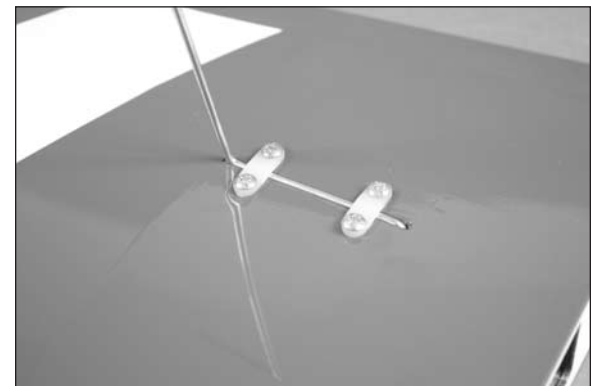

Etips

Always use threadlock on metal-to-metal fasteners to prevent them from vibrating loose.

- ○ 6. Use two 2.5mm wheel collars to secure the 51mm foam wheel to the landing gear. The setscrews are tightened using a 1.5mm hex wrench.



- ○ 7. Repeat steps 1 through 6 to install the remaining landing gear and wheel.

Wing Installation

Required Parts

Wing panel with aileron (left and right)
Aluminum wing tube
3mm x 10mm socket head cap screw (4)
3mm washer (4)

Required Tools and Adhesives

Hex wrench: 2.5mm

- 1. Slide the aluminum wing tube into the socket in the wing panel. The tube will slide in easily, so do not force it in any farther than it will easily slide.



- 2. Slide the tube into the socket in the fuselage. Make sure to guide the lead for the aileron servo in the fuselage when positioning the wing.



- ○ 3. Use two 3mm x 10mm socket head cap screws and two 3mm washers to secure the position of the wing. Use a 2.5mm hex wrench to tighten the screws. Plug the aileron servo into the receiver if you are preparing your model for flight.



- 4. Repeat step 3 to install the second wing panel.

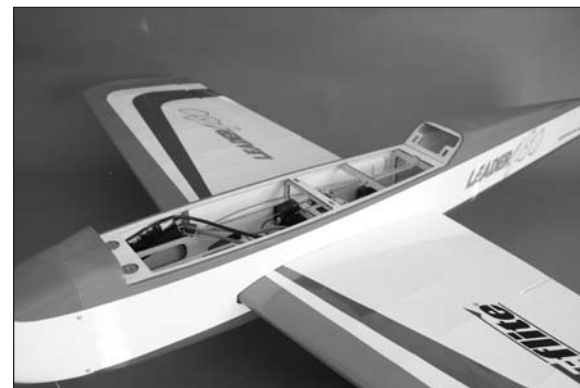

Stabilizer Installation

Required Parts

Fuselage assembly Stabilizer

Required Tools and Adhesives

Thin CA Felt-tipped pen
Ruler Hobby knife with #11 blade

- 1. Remove the elevator from the stabilizer. Set the elevator and four CA hinges aside until later. Use a felt-tipped pen and ruler to mark a center on the trailing edge of the stabilizer. This will provide a starting point when checking the alignment of the stabilizer.

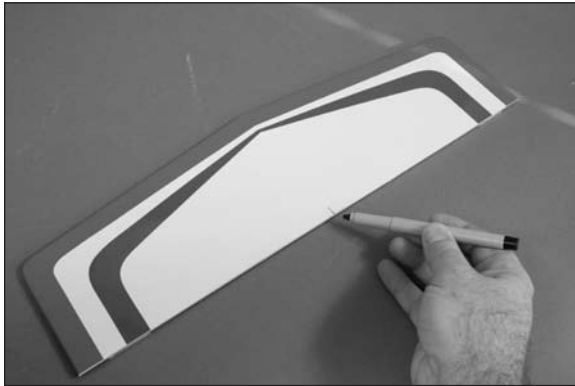

E-tips

It is important to check the alignment of the stabilizer in relationship to the wing. Not doing so may cause your airplane to require excessive amounts of trim to correct for poor alignment, resulting in poor flight performance.

- 2. Measure the distance from each stabilizer tip to the fuselage centerline to make sure the stabilizer is centered on the fuselage.

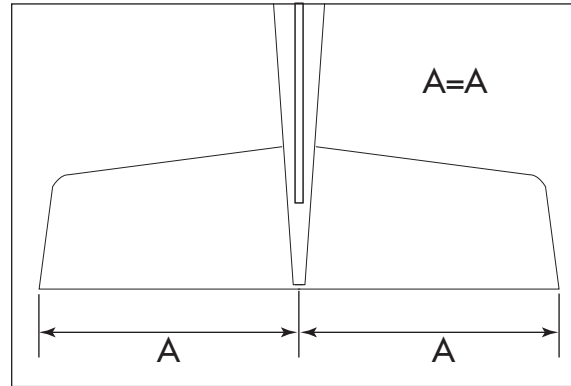

- 3. Stand back 8–10 feet (2–3 meters) and view the aircraft from the rear. Check the alignment between the wing and stabilizer. They must be equal distance on each side as shown. If not, lightly sand the stabilizer saddle to correct any alignment problems.

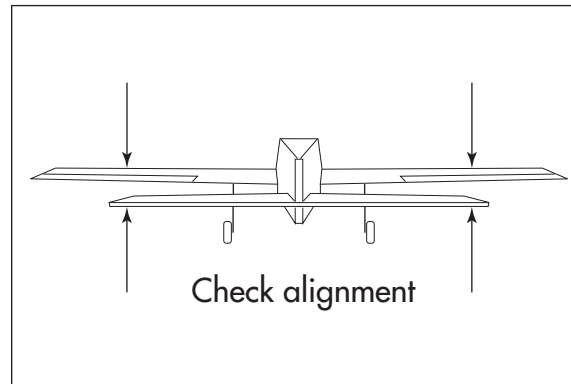

- 4. Measure the distance from each stabilizer tip to the outside corner of the aileron hinge line. These measurements must match as close as possible. Adjust the position of the stabilizer if necessary to position the stabilizer.

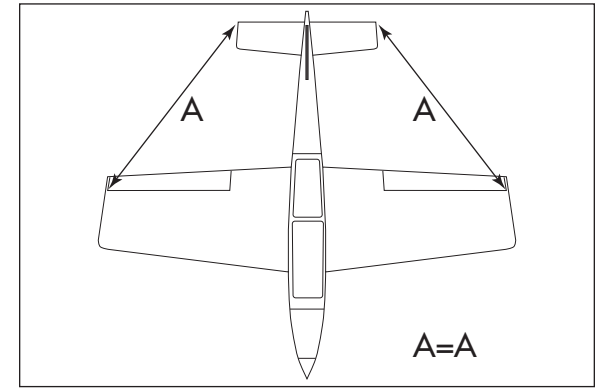

- 5. Once the stabilizer has been aligned to the wing, use a felt-tipped pen to trace the outline of the fuselage on the bottom of the stabilizer.



E-tips

When cutting through the covering, use a new #11 blade and light pressure to avoid cutting into the underlying wood, which could weaken the underlying structure, causing it to fail in flight. We also recommend using a hot knife to melt through the covering to help reduce damaging the underlying wood.

- 6. Remove the stabilizer from the fuselage. Use a hobby knife and #11 blade to trim the covering inside the lines drawn in the previous step by 1/16-inch (1.5mm). Remove the covering, exposing the bare wood. The lines can be removed using a paper towel and rubbing alcohol.



E-tips

Do not use CA accelerator when gluing the stabilizer to the fuselage. The CA must be allowed to soak into the fuselage and stabilizer for the best bond between the two surfaces.

- 7. Place the stabilizer back on the fuselage. Recheck the alignment. Wick thin CA into the joint between the stabilizer and fuselage. Allow the CA to fully cure before proceeding.



Vertical Fin Installation

Required Parts

Fuselage assembly Fin

Required Tools and Adhesives

Felt-tipped pen Thin CA
Square Hobby knife with #11 blade

- 1. Remove the rudder from the fin. Set the rudder and three CA hinges aside until later. Place the fin in the slot on the top of the fuselage.



- 2. Use a felt-tipped pen to trace the outline of the fuselage on the bottom of the fin.



E-tips

When cutting through the covering, use a new #11 blade and light pressure to avoid cutting into the underlying wood, which could weaken the underlying structure, causing it to fail in flight. We also recommend using a hot knife to melt through the covering to help reduce damaging the underlying wood.

- 3. Remove the fin from the fuselage. Use a hobby knife and #11 blade to trim the covering below the lines drawn in the previous step by 1/16-inch (1.5mm). Remove the covering, exposing the bare wood. The lines can be removed using a paper towel and rubbing alcohol.

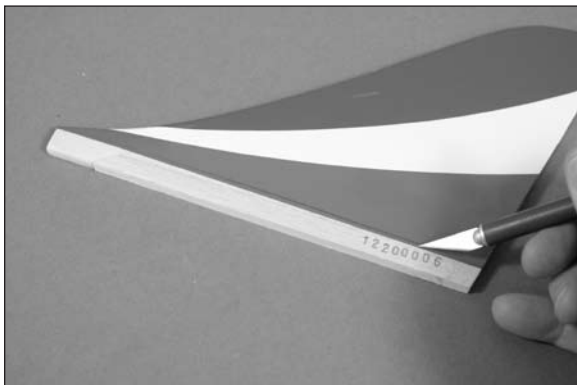

- 4. Place the fin back in the slot on the top of the fuselage. Use a square to make sure the fin is positioned 90-degrees to the stabilizer. If not, lightly sand the exposed wood on the bottom of the fin to correct its alignment.

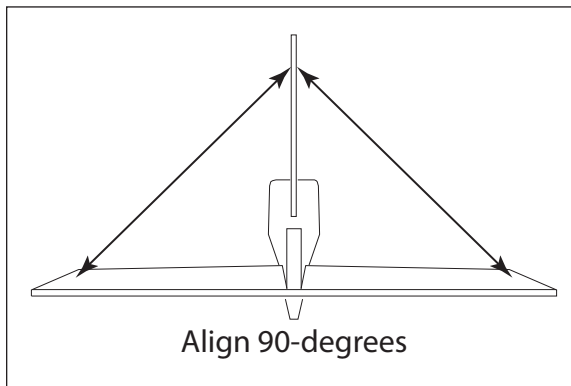

E-tips

Do not use CA accelerator when gluing the fin to the fuselage. The CA must be allowed to soak into the fuselage and fin for the best bond between the two surfaces.

- 5. Once aligned, wick thin CA into the joint between the fin and fuselage. Allow the CA to fully cure before proceeding.



Rudder and Elevator Installation

Required Parts

Fuselage assembly	Rudder
Elevator	Control horn with backplate (2)
CA hinge (7)	

Required Tools and Adhesives

Thin CA	T-pins
Pin vise	Drill bit: 1/16-inch (1.5mm)
Threadlock	Side cutter

- 1. Use a pin vise and 1/16-inch (1.5mm) drill bit to drill a hole in the center of each hinge slot to create a tunnel for the CA to wick into. This will allow the CA to penetrate the hinge, creating a better bond between the hinge and surrounding wood. Prepare the rudder and fin at this time.

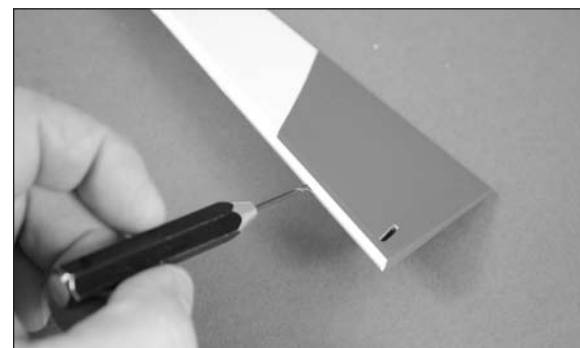

- 2. Place T-pin in the center of each of the three rudder (or four elevator) hinges. This will center the hinges equally in each surface when they are installed.

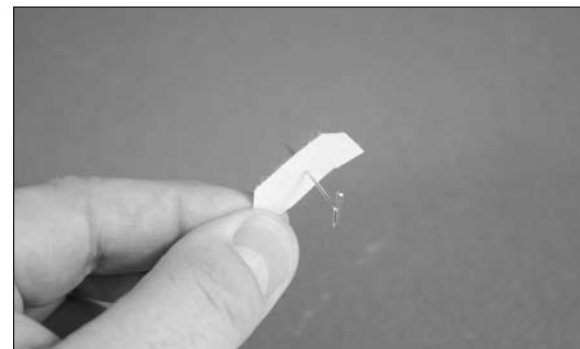

- 3. Insert the hinges in the rudder (or elevator). The T-pin will rest on the edge of the bevel of the control surface.

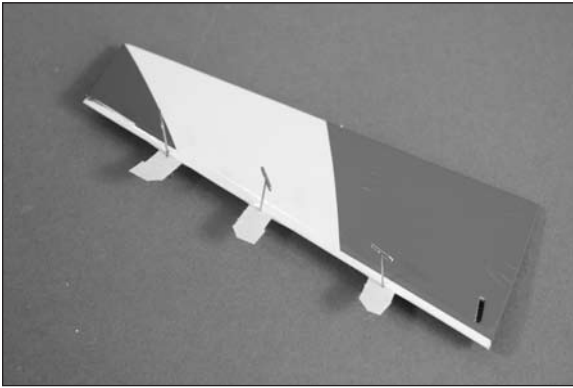

- 4. Slide the rudder (or elevator) into position. Make sure the tip of the control surface is aligned with the tip of the fixed surface.

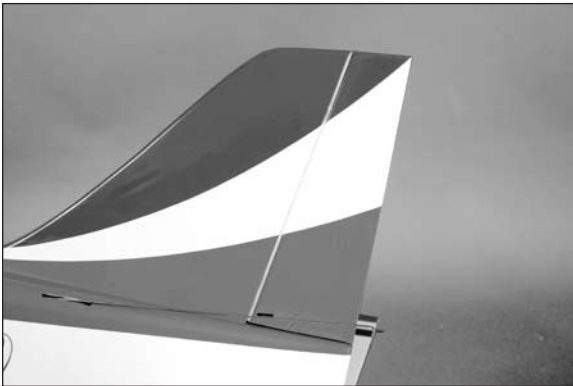

- 5. Saturate each hinge with thin CA. Apply CA to both side of the hinge.

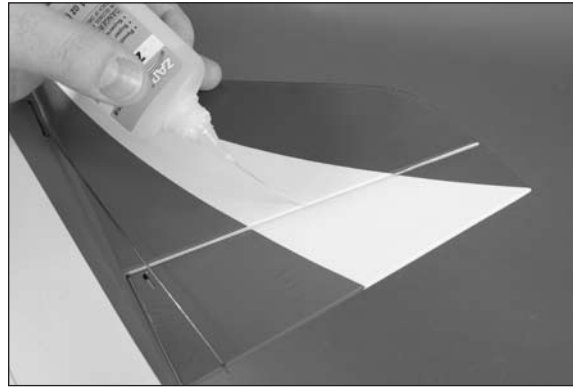

E-tips

Do not use CA accelerator when gluing the hinges. The CA must be allowed to soak into the hinge for the best bond between the hinge and surrounding wood.

- 6. Once the CA has cured, gently pull on the control surface and fin to make sure the hinges are glued securely. If not, apply CA to those hinges that are not glued and recheck.

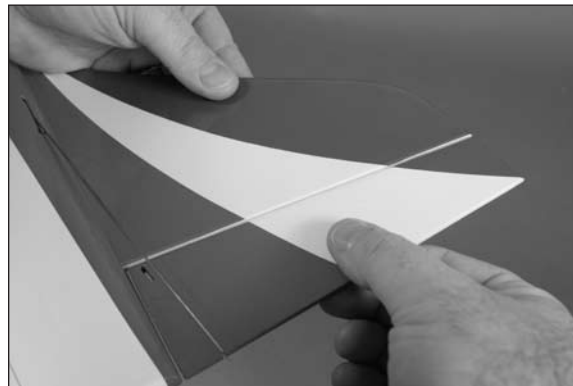

- 7. Move the rudder through its range of motion a number of times to break in the hinges. This will reduce the initial load on the servo during your first flights.

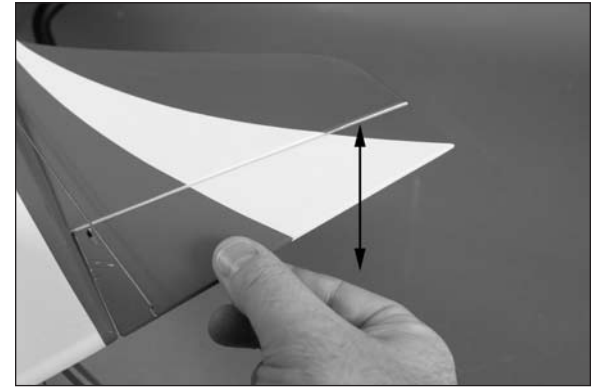

- 8. Pass the Z-bend in the rudder (or elevator) pushrod through the outer hole of the control horn.



- ○ 9. Insert the control horn in the slit in the rudder (or elevator).



- ○ 10. Slide the control horn backplate over the end of the control horn from the opposite side of the control surface. Snap the backplate so the horn is held tightly in position. Apply 2–3 drops of thin CA to the backplate where it contacts the control horn to keep it from accidentally coming loose in flight.



Etips

Before gluing the backplate in position, trim the front edge of the backplate so it does not cause binding in extreme throws. Temporarily snap the backplate into position and mark the backplate along the bevel with a felt tipped pin. Remove the backplate and use side cutters to trim the backplate. Use sandpaper to sand the backplate to its final shape before gluing it in position.

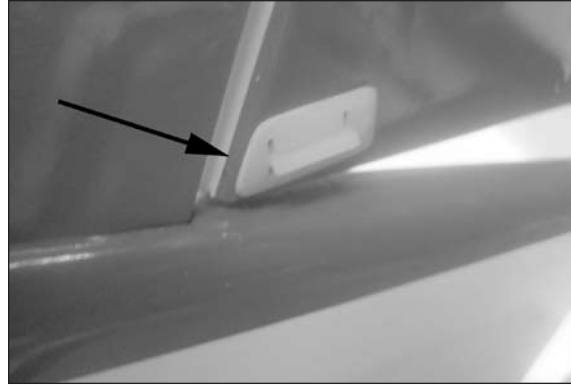

Etips

Always use threadlock on metal-to-metal fasteners to prevent them from vibrating loose.

- ○ 11. Use the radio system to center the rudder servo. Center the rudder so it is aligned with the fin (or the elevator to the stabilizer). Tighten the screw in the pushrod connector to secure the pushrod wire. Use side cutters to trim the excess length of wire that extends beyond the connector as shown.



- 12. Repeat steps 1 through 11 to install the elevator and associated hardware.

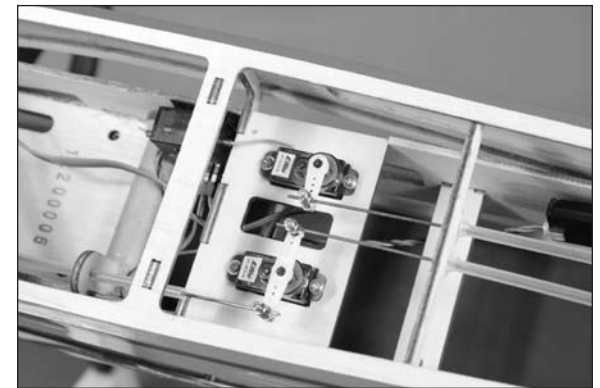

Motor Battery Installation

Required Parts

Fuselage assembly Motor battery
Hook and loop strap (not included) (2)
Hook and loop tape (not included)

- 1. Secure the motor battery in the fuselage using two hook and loop straps (not included). We recommend using hook and loop tape between the battery and battery tray to keep the battery from sliding on the tray during flight.

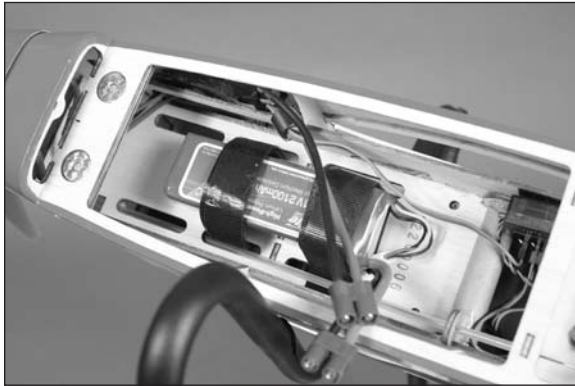

E-tips

Make sure not to wrap the hook and loop strap around any wires or pushrods. Wrapping it around the steering pushrod will increase the load on the rudder servo, which could cause the servo to fail due to the increased loads.

Optional Pilot Installation

Required Parts

Canopy Pilot (optional)
Balsa stiffener (2)

Required Tools and Adhesives

Felt-tipped pen Ruler
Razor saw Medium CA
Sanding block Medium grit sandpaper
Hobby knife with #11 blade

- 1. Use a felt-tipped pen to mark the pilot 1/2-inch (13mm) up from the bottom as shown.

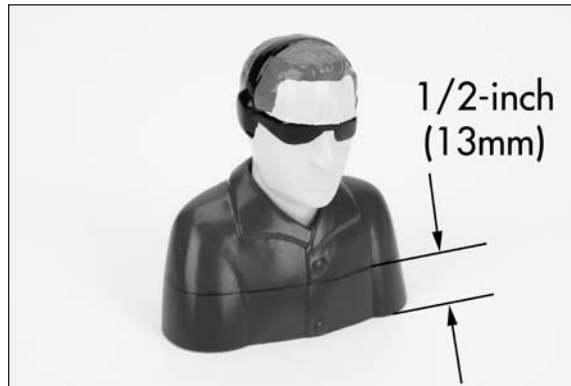

- 2. Use a razor saw to trim the pilot along the line made in the previous step. Use a sanding block and medium grit sandpaper to smooth the bottom of the pilot flat.



- 3. Remove the balsa plate from the inside of the portion of the pilot trimmed in the previous step. Fit the plate into the bottom of the pilot. You may need to lightly sand the plate to fit. Once fit, use medium CA to glue the plate in the pilot. Allow the CA to fully cure before proceeding.



- 4. Use medium CA to glue the two balsa stiffeners to the bottom of the pilot. These will keep the pilot from falling into the canopy, and provide a way to secure the pilot.





- 5. Use a hobby knife and #11 blade to remove the covering from the canopy. Test fit the pilot into the canopy. It may be necessary to lightly sand to opening to fit the pilot.



- 6. Once satisfied with the fit, use medium CA to glue the pilot in the canopy. Apply the glue to the stiffeners to keep the pilot in the canopy.



Center of Gravity

Required Parts

Assembled airframe

Required Tools and Adhesives

Felt-tipped pen Ruler

Phillips screwdriver: #2

Balancing stand (optional)

An important part of preparing the aircraft for flight is properly balancing the model.



CAUTION: Do not inadvertently skip this step or property damage and injury could occur.

- 1. Assemble your model in preparation for flight, making sure the wing is on securely and the motor battery is installed as instructed in this manual.
- 2. The recommended Center of Gravity (CG) location for your model is $3\frac{3}{8}$ to $3\frac{3}{4}$ inches (85 to 95mm) back from the leading edge of the wing as shown with the battery pack installed. Mark the location of the CG on the top of the wing with a felt-tipped pen.

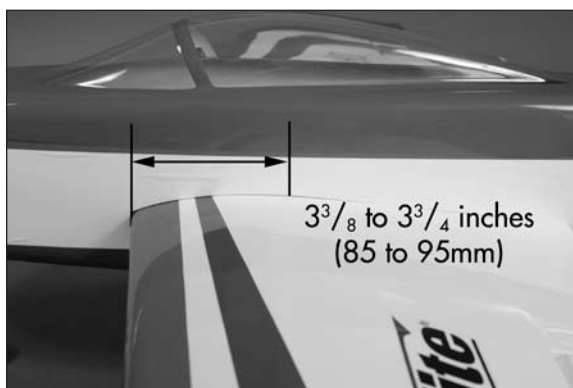

- 3. When balancing your model, support the plane inverted at the marks made on the top of the wing with your fingers or a commercially available balancing stand. This is the correct balance point for your model. Make sure your model is assembled and ready for flight before balancing.

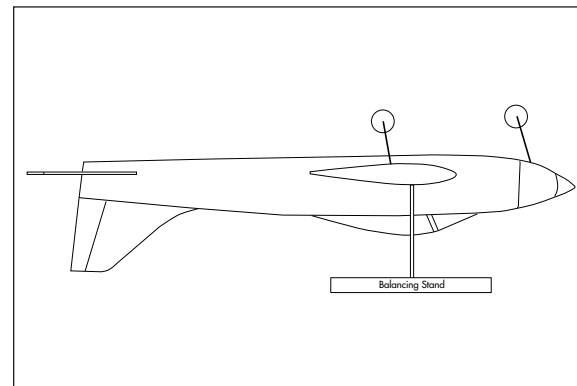

Adjust the motor battery as necessary so the model is level or slightly nose down. This is the correct balance point for your model. You should find the CG to be very close with the battery installed as shown in this manual. Mark the location of the battery on the battery tray using a felt-tipped pen so it can be returned to this position if it is removed from your model.

After the first flights, the CG position can be adjusted for your personal preference.

Control Throws

- 1. Turn on the transmitter and receiver of your model. Check the movement of the rudder using the transmitter. When the stick is moved right, the rudder should also move right. Reverse the direction of the servo at the transmitter if necessary.
- 2. Check the movement of the elevator with the radio system. Moving the elevator stick toward the bottom of the transmitter makes the airplane elevator move up.
- 3. Check the movement of the ailerons with the radio system. Moving the aileron stick right makes the right aileron move up and the left aileron move down.
- 4. Use a ruler to adjust the throw of the elevator, ailerons and rudder. Adjust the position of the pushrod at the control horn to achieve the following measurements when moving the sticks to their endpoints.

Elevator High Rate (100%) (30% Exponential)

Up 23/32-inch (18mm)
Down 25/32-inch (20mm)

Elevator Low Rate (20% Exponential)

Up 5/16-inch (8mm)
Down 11/32-inch (9mm)

Aileron High Rate (100%) (40% Exponential)

Up 25/32-inch (20mm)
Down 25/32-inch (20mm)

Aileron Low Rate (33% Exponential)

Up 19/32-inch (15mm)
Down 19/32-inch (15mm)

Rudder High Rate (100%) (30% Exponential)

Right 1³/₁₆-inch (30mm)
Left 1³/₁₆-inch (30mm)

Rudder Low Rate (20% Exponential)

Right 25/32-inch (20mm)
Left 25/32-inch (20mm)

E-tips

Measurements are taken at the inner or widest point on the control surface.

These are general guidelines measured from our own flight tests. You can experiment with higher rates to match your preferred style of flying.

E-tips

Travel Adjust and Sub-Trims are not listed and should be adjusted according to each individual model and preference. Always install the control horns 90-degrees to the servo centerline. Use sub-trim as a last resort to center the servos.

E-tips

We highly recommend re-binding the radio system once all the control throws are set. This will keep the servos from moving to their endpoints until the transmitter and receiver connect.

Preflight

Check Your Radio

Before going to the field, be sure your batteries are fully charged per the instructions included with your radio. Charge the transmitter and motor battery for your airplane. Use the recommended charger supplied with your particular radio system, following the instructions provided with the radio. In most cases, the radio should be charged the night before going out flying.

Before each flying session, be sure to range check your radio. See your radio manual for the recommended range and instructions for your radio system. Each radio manufacturer specifies different procedures for their radio systems. Next, run the motor. With the model securely anchored, check the range again. The range test should not be significantly affected. If it is, don't attempt to fly! Have your radio equipment checked out by the manufacturer.

Double-check that all controls (aileron, elevator, rudder and throttle) move in the correct direction.

Check the radio installation and make sure all the control surfaces are moving correctly (i.e., the correct direction and with the recommended throws).

Check all the control horns, servo horns, and clevises to make sure they are secure and in good condition.

Range Test Your Radio

Before each flying session, and especially with a new model, it is important to perform a range check. It is helpful to have another person available to assist during the range check. If you are using a Spektrum transmitter, please refer to your transmitter's manual for detailed instructions on the range check process.

- 1. With the model resting on the ground, stand 30 paces (approximately 90 feet) away from the model.
- 2. Face the model with the transmitter in your normal flying position. Be sure the throttle is in the full down position and plug the flight battery into the speed control.
- 3. As you move the controls, watch to be sure the airplane's motor and controls operate smoothly. You should have total control of the model at 30 paces (90 feet).
- 4. If control issues exist, call the appropriate Horizon Product Support office (see page 43) or go to horizonhobby.com to find a local Spektrum distributor in your country for service if using a Spektrum radio system.

Flying Your Model

The Leader 480 is an extremely well mannered low-wing park flyer with the heart of a pattern plane.

Its ground handling characteristics are very forgiving due to the tricycle landing gear arrangement. Set the throttle trim such that the propeller is spinning over at a very low RPM. Taxi out to the runway and line up with the centerline and check to ensure that the controls are moving in the correct directions and that your rate switches are set to their proper positions. Smoothly advance the throttle and hold slight back pressure on the elevator. Use very small rudder corrections to keep the airplane tracking straight down the runway, and the Leader should gently break ground after a short takeoff roll and settle into a moderate climb angle. Once at altitude, set cruise power to between $\frac{1}{2}$ to $\frac{3}{4}$ throttle and trim for straight and level flight. After trimming and making a few passes, try some slow flight. Point the nose into the wind and reduce power and feed up elevator to maintain level flight. The airplane will slow down to a crawl and break straight ahead.

Now for the fun part. With the light weight of the airframe, and the power of the Park 480 motor, the Leader 480 is a very capable aerobatic performer. Due to the force arrangement and the generous tail moment, the Leader tracks incredible lines. Big loops, slow axial rolls, snap rolls, inverted flight, spins, stall turns, and more are well within this agile flyer's realm of capability. Use your imagination to create your own aerobatic sequence for endless fun.

When the time comes bring this bird back to earth, fly parallel to the runway downwind and slowly reduce power. Begin to bleed off airspeed and descend. Once lined up with the runway, use the elevator to control airspeed and power to control rate of descent and establish a stable glidepath to the approach end of the runway. Once you are a few feet above the runway, begin to shallow your descent rate and reduce power completely. Once you settle into ground effect, it will settle onto the runway in a slightly nose-high attitude. If the nose is kept high during the roll out, speed will bleed off much quicker. Just as with the takeoff, use small rudder corrections to keep the airplane tracking straight down the runway.

Congratulations, you have just flown your Leader 480! We wish you many more happy flights with this model. Now grab a battery and do it again!

Happy Landings!

Daily Flight Checks

- 1. Check the battery voltage of the transmitter battery. Do not fly below the manufacturer's recommended voltage. To do so can crash your aircraft.

E-tips

When you check these batteries, ensure you have the polarities correct on your expanded scale voltmeter.

- 2. Check all hardware (linkages, screws, nuts, and bolts) prior to each day's flight. Be sure that binding does not occur and that all parts are properly secured.
- 3. Ensure all surfaces are moving in the proper manner.
- 4. Perform a ground range check before each day's flying session.
- 5. Prior to starting your aircraft, turn off your transmitter, then turn it back on. Do this each time you start your aircraft. If any critical switches are on without your knowledge, the transmitter alarm will sound a warning at this time.
- 6. Check that all trim levers are in the proper location.
- 7. All servo pigtails and switch harness plugs should be secured in the receiver. Make sure the switch harness moves freely in both directions.

Warranty and Repair Policy

WARRANTY PERIOD

Exclusive Warranty- Horizon Hobby, Inc., (Horizon) warranties that the Products purchased (the "Product") will be free from defects in materials and workmanship at the date of purchase by the Purchaser.

LIMITED WARRANTY

Horizon reserves the right to change or modify this warranty without notice and disclaims all other warranties, express or implied.

(a) This warranty is limited to the original Purchaser ("Purchaser") and is not transferable. REPAIR OR REPLACEMENT AS PROVIDED UNDER THIS WARRANTY IS THE EXCLUSIVE REMEDY OF THE PURCHASER. This warranty covers only those Products purchased from an authorized Horizon dealer. Third party transactions are not covered by this warranty. Proof of purchase is required for all warranty claims.

(b) Limitations- HORIZON MAKES NO WARRANTY OR REPRESENTATION, EXPRESS OR IMPLIED, ABOUT NON-INFRINGEMENT, MERCHANTABILITY OR FITNESS FOR A PARTICULAR PURPOSE OF THE PRODUCT. THE PURCHASER ACKNOWLEDGES THAT THEY ALONE HAVE DETERMINED THAT THE PRODUCT WILL SUITABLY MEET THE REQUIREMENTS OF THE PURCHASER'S INTENDED USE.

(c) Purchaser Remedy- Horizon's sole obligation hereunder shall be that Horizon will, at its option, (i) repair or (ii) replace, any Product determined by Horizon to be defective. In the event of a defect, these are the Purchaser's exclusive remedies. Horizon reserves the right to inspect any and all equipment involved in a warranty claim. Repair or replacement decisions are at the sole discretion of Horizon. This warranty does not cover cosmetic damage or damage due to acts of God, accident, misuse, abuse, negligence, commercial use, or modification of or to any part of the Product. This warranty does not cover damage due to improper installation, operation, maintenance, or attempted repair by anyone other than Horizon. Return of any Product by Purchaser must be approved in writing by Horizon before shipment.

DAMAGE LIMITS

HORIZON SHALL NOT BE LIABLE FOR SPECIAL, INDIRECT OR CONSEQUENTIAL DAMAGES, LOSS OF PROFITS OR PRODUCTION OR COMMERCIAL LOSS IN ANY WAY CONNECTED WITH THE PRODUCT, WHETHER SUCH CLAIM IS BASED IN CONTRACT, WARRANTY, NEGLIGENCE, OR STRICT LIABILITY. Further, in no event shall the liability of Horizon exceed the individual price of the Product on which liability is asserted. As Horizon has no control over use, setup, final assembly, modification or misuse, no liability shall be assumed nor accepted for any resulting damage or injury. By the act of use, setup or assembly, the user accepts all resulting liability.

If you as the Purchaser or user are not prepared to accept the liability associated with the use of this Product, you are advised to return this Product immediately in new and unused condition to the place of purchase.

Law: These Terms are governed by Illinois law (without regard to conflict of law principals).

Warranty Services

QUESTIONS, ASSISTANCE, AND REPAIRS

Your local hobby store and/or place of purchase cannot provide warranty support or repair. Once assembly, setup or use of the Product has been started, you must contact Horizon directly. This will enable Horizon to better answer your questions and service you in the event that you may need any assistance. For questions or assistance, please direct your email to productsupport@horizonhobby.com, or call 877.504.0233 toll free to speak to a Product Support representative. You may also find information on our website at www.horizonhobby.com.

INSPECTION OR REPAIRS

If this Product needs to be inspected or repaired, please use the Horizon Online Repair Request submission process found on our website or call Horizon to obtain a Return Merchandise Authorization (RMA) number. Pack the Product securely using a shipping carton. Please note that original boxes may be included, but are not designed to withstand the rigors of shipping without additional protection. Ship via a carrier that provides tracking and insurance for lost or damaged parcels, as Horizon is not responsible for merchandise until it arrives and is accepted at our facility. An Online Repair Request is available at www.horizonhobby.com <http://www.horizonhobby.com> under the Repairs tab. If you do not have internet access, please contact Horizon Product Support to obtain a RMA number along with instructions for submitting your product for repair. When calling Horizon, you will be asked to provide your complete name, street address, email address and phone number where you can be reached during business hours. When sending product into Horizon, please include your RMA number, a list of the included items, and a brief summary of the problem. A copy of your original sales receipt must be included for warranty consideration. Be sure your name, address, and RMA number are clearly written on the outside of the shipping carton.

Notice: Do not ship batteries to Horizon. If you have any issue with a battery, please contact the appropriate Horizon Product Support office.

WARRANTY INSPECTION AND REPAIRS

To receive warranty service, you must include your original sales receipt verifying the proof-of-purchase date. Provided warranty conditions have been met, your Product will be repaired or replaced free of charge. Repair or replacement decisions are at the sole discretion of Horizon.

NON-WARRANTY REPAIRS

Should your repair not be covered by warranty the repair will be completed and payment will be required without notification or estimate of the expense unless the expense exceeds 50% of the retail purchase cost. By submitting the item for repair you are agreeing to payment of the repair without notification. Repair estimates are available upon request. You must include this request with your repair. Non-warranty repair estimates will be billed a minimum of ½ hour of labor. In addition you will be billed for return freight. Horizon accepts money orders and cashiers checks, as well as Visa, MasterCard, American Express, and Discover cards. By submitting any item to Horizon for inspection or repair, you are agreeing to Horizon's Terms and Conditions found on our website under the Repairs tab.

UNITED STATES

(Electronics and engines)
Horizon Service Center
4105 Fieldstone Rd
Champaign, Illinois
61822 USA
877-504-0233

Online Repair Request visit:
www.horizonhobby.com/repairs

(All other products)
Horizon Product Support
4105 Fieldstone Rd
Champaign, Illinois
61822 USA
productsupport@horizonhobby.com
877-504-0233

UNITED KINGDOM

Horizon Hobby Limited
Units 1-4 Ployters Rd
Staple Tye
Harlow, Essex
CM18 7NS
United Kingdom
sales@horizonhobby.co.uk
+44 (0) 1279 641 097

GERMANY

Horizon Technischer Service
Hamburger Str. 10
25335 Elmshorn
Germany
service@horizonhobby.de
+49 4121 46199 66

FRANCE

Horizon Hobby SAS
14 Rue Gustave Eiffel
Zone d'Activité du Réveil Matin
91230 Montgeron
infofrance@horizonhobby.com
+33 (0) 1 60 47 44 70

Compliance Information for the European Union



INSTRUCTIONS FOR DISPOSAL OF WEEE BY USERS IN THE EUROPEAN UNION

This product must not be disposed of with other waste. Instead, it is the user's responsibility to dispose of their waste equipment by handing it over to a designated collection point for the recycling of waste electrical and electronic equipment. The separate collection and recycling of your waste equipment at the time of disposal will help to conserve natural resources and ensure that it is recycled in a manner that protects human health and the environment. For more information about where you can drop off your waste equipment for recycling, please contact your local city office, your household waste disposal service or where you purchased the product.

Academy of Model Aeronautics National Model Aircraft Safety Code

Effective January 1, 2011

A. GENERAL

A model aircraft is a non-human-carrying aircraft capable of sustained flight in the atmosphere. It may not exceed limitations of this code and is intended exclusively for sport, recreation and/or competition. All model flights must be conducted in accordance with this safety code and any additional rules specific to the flying site.

1. Model aircraft will not be flown:
 - (a) In a careless or reckless manner.
 - (b) At a location where model aircraft activities are prohibited.
2. Model aircraft pilots will:
 - (a) Yield the right of way to all man carrying aircraft.
 - (b) See and avoid all aircraft and a spotter must be used when appropriate. (AMA Document #540-D-See and Avoid Guidance.)
 - (c) Not fly higher than approximately 400 feet above ground level within three (3) miles of an airport, without notifying the airport operator.
 - (d) Not interfere with operations and traffic patterns at any airport, heliport or seaplane base except where there is a mixed use agreement.
 - (e) Not exceed a takeoff weight, including fuel, of 55 pounds unless in compliance with the AMA Large Model Aircraft program. (AMA Document 520-A)
 - (f) Ensure the aircraft is identified with the name and address or AMA number of the owner on the inside or affixed to the outside of the model aircraft. (This does not apply to model aircraft flown indoors).
 - (g) Not operate aircraft with metal-blade propellers or with gaseous boosts except for helicopters operated under the provisions of AMA Document #555.
 - (h) Not operate model aircraft while under the influence of alcohol or while using any drug which could adversely affect the pilot's ability to safely control the model.

(i) Not operate model aircraft carrying pyrotechnic devices which explode or burn, or any device which propels a projectile or drops any object that creates a hazard to persons or property.

Exceptions:

- Free Flight fuses or devices that burn producing smoke and are securely attached to the model aircraft during flight.
 - Rocket motors (using solid propellant) up to a G-series size may be used provided they remain attached to the model during flight. Model rockets may be flown in accordance with the National Model Rocketry Safety Code but may not be launched from model aircraft.
 - Officially designated AMA Air Show Teams (AST) are authorized to use devices and practices as defined within the Team AMA Program Document (AMA Document #718).
 - (i) Not operate a turbine-powered aircraft, unless in compliance with the AMA turbine regulations. (AMA Document #510-A).
3. Model aircraft will not be flown in AMA sanctioned events, air shows or model demonstrations unless:
 - (a) The aircraft, control system and pilot skills have successfully demonstrated all maneuvers intended or anticipated prior to the specific event.
 - (b) An inexperienced pilot is assisted by an experienced pilot.
 4. When and where required by rule, helmets must be properly worn and fastened. They must be OSHA, DOT, ANSI, SNELL or NOCSAE approved or comply with comparable standards.

B. RADIO CONTROL (RC)

1. All pilots shall avoid flying directly over unprotected people, vessels, vehicles or structures and shall avoid endangerment of life and property of others.
2. A successful radio equipment ground-range check in accordance with manufacturer's recommendations will be completed before the first flight of a new or repaired model aircraft.

3. At all flying sites a safety line(s) must be established in front of which all flying takes place (AMA Document #706-Recommended Field Layout):
 - (a) Only personnel associated with flying the model aircraft are allowed at or in front of the safety line.
 - (b) At air shows or demonstrations, a straight safety line must be established.
 - (c) An area away from the safety line must be maintained for spectators.
 - (d) Intentional flying behind the safety line is prohibited.
4. RC model aircraft must use the radio-control frequencies currently allowed by the Federal Communications Commission (FCC). Only individuals properly licensed by the FCC are authorized to operate equipment on Amateur Band frequencies.
5. RC model aircraft will not operate within three (3) miles of any pre-existing flying site without a frequency-management agreement (AMA Documents #922- Testing for RF Interference; #923- Frequency Management Agreement)
6. With the exception of events flown under official AMA Competition Regulations, excluding takeoff and landing, no powered model may be flown outdoors closer than 25 feet to any individual, except for the pilot and the pilot's helper(s) located at the flight line.
7. Under no circumstances may a pilot or other person touch a model aircraft in flight while it is still under power, except to divert it from striking an individual. This does not apply to model aircraft flown indoors.
8. RC night flying requires a lighting system providing the pilot with a clear view of the model's attitude and orientation at all times.
9. The pilot of a RC model aircraft shall:
 - (a) Maintain control during the entire flight, maintaining visual contact without enhancement other than by corrective lenses prescribed for the pilot.
 - (b) Fly using the assistance of a camera or First-Person View (FPV) only in accordance with the procedures outlined in AMA Document #550.

C. FREE FLIGHT

1. Must be at least 100 feet downwind of spectators and automobile parking when the model aircraft is launched.
2. Launch area must be clear of all individuals except mechanics, officials, and other fliers.
3. An effective device will be used to extinguish any fuse on the model aircraft after the fuse has completed its function.

D. CONTROL LINE

1. The complete control system (including the safety thong where applicable) must have an inspection and pull test prior to flying.
2. The pull test will be in accordance with the current Competition Regulations for the applicable model aircraft category.
3. Model aircraft not fitting a specific category shall use those pull-test requirements as indicated for Control Line Precision Aerobatics.
4. The flying area must be clear of all utility wires or poles and a model aircraft will not be flown closer than 50 feet to any above-ground electric utility lines.
5. The flying area must be clear of all nonessential participants and spectators before the engine is started.

Building and Flying Notes



© 2011 Horizon Hobby, Inc.
horizonhobby.com
www.e-fliterc.com

The Spektrum trademark is used with permission of Bachmann Industries, Inc.

E-flite, DSM, DSM2 and DSMX are trademarks or registered trademarks of Horizon Hobby, Inc.

All other trademarks, service marks and logos are the property of their respective owners.