

Name: _____		Date: _____		Event: _____	
City: _____		State: _____		Track: _____	
Track	<input type="checkbox"/> Indoor	<input type="checkbox"/> Tight	<input type="checkbox"/> Smooth	<input type="checkbox"/> Hard Packed	<input type="checkbox"/> Blue Groove
Conditions	<input type="checkbox"/> Outdoor	<input type="checkbox"/> Open	<input type="checkbox"/> Rough	<input type="checkbox"/> Loose/Loamy	<input type="checkbox"/> Dry
	<input type="checkbox"/> Wet	<input type="checkbox"/> Low Bite	<input type="checkbox"/> High Bite	<input type="checkbox"/> Dusty	<input type="checkbox"/> Med Bite
		<input type="checkbox"/> Other	_____		

Front Suspension

Toe: _____
 Ride Height: _____
 Camber: _____
 Caster: _____
 Spindle Height: High Low
 Wheel Hex: _____
 Sway Bar: _____
 Piston/Oil: _____
 Shock Type: Bladder Emulsion
 Spring: _____
 Limiter/Droop: _____
 Overall Shock Length: _____
 Steering Ackerman: _____
 Bump Steer: _____
 Camber Link: _____
 Shock Location: _____
 Receiver Battery Type: _____

Differentials

Front: Standard Smart
 Spring Wire Dia. _____
 Qty of Springs: _____
 Ramp Plate: _____
 Grease: _____
 Diff Fluid: _____
 Center: Standard Smart
 Spring Wire Dia.: _____
 Qty of Springs: _____
 Ramp Plate: _____
 Grease: _____
 Diff Fluid: _____

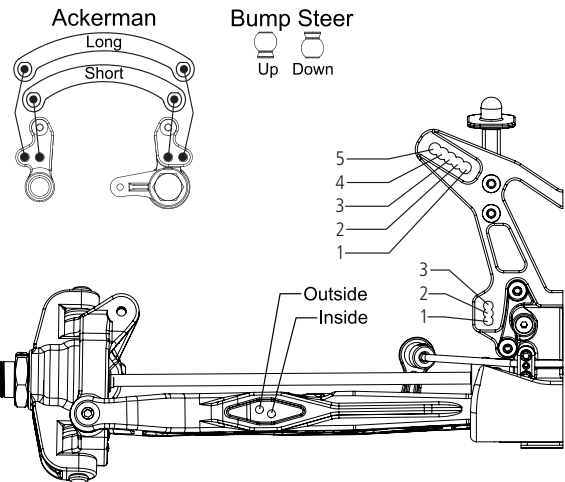

Notes: _____

Rear Suspension

Roll Center: HRC LRC
 Toe: _____
 Anti-Squat: _____
 Ride Height: _____
 Camber: _____
 Rear Hub Spacing: _____
 Wheel Hex: _____
 Sway Bar: _____
 Piston/Oil: _____
 Shock Type: Bladder Emulsion
 Spring: _____
 Limiter/Droop: _____
 Overall Shock Length: _____
 Camber Link: _____
 Shock Position: _____
 Rear Diff Fluid: _____

Wing Setup

Wing Type: 2.0 3.0
 Wing Spacer: .250 .500
 Wicker Bill: .250 .350

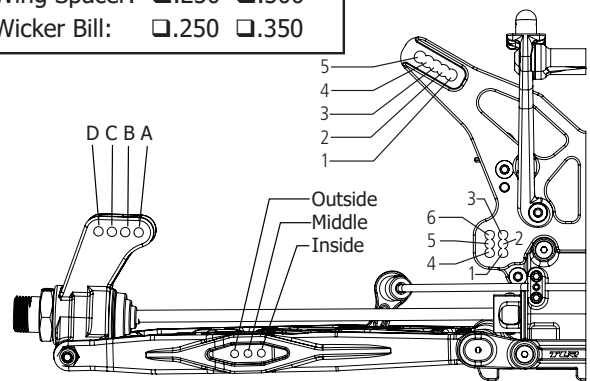

Notes: _____

Engine

Engine: _____ Fuel: _____
 Glow Plug: _____ Head Clearance _____
 Pipe/Header: _____ Gearing: _____

Clutch

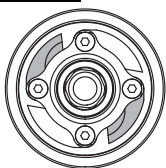

Clutch Shoes and Springs Info

Tires

Type Compound Insert

Front: _____
 Rear: _____
 Notes: _____