

**HORIZON**<sup>®</sup>  
H O B B Y

**Eflite**<sup>®</sup>  
ADVANCING ELECTRIC FLIGHT

# Pawnee Brave Night Flyer

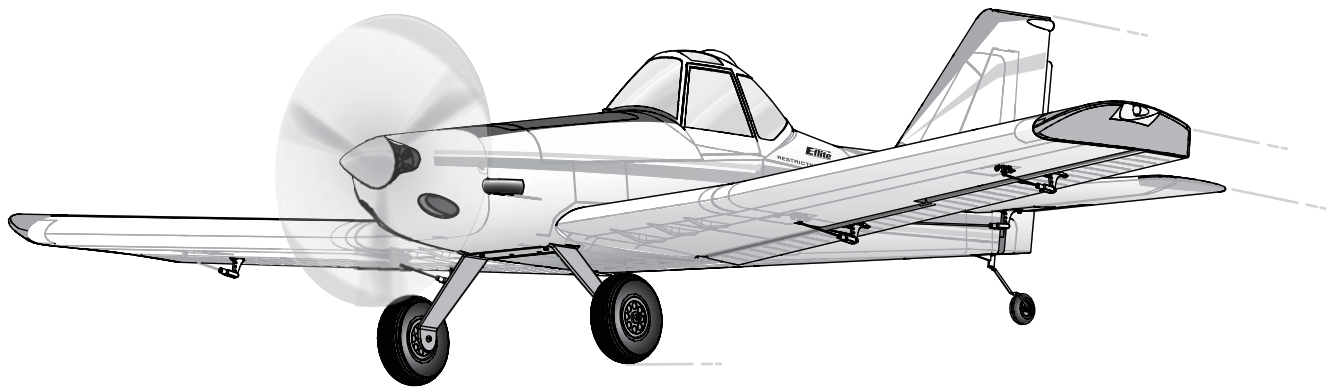

*Instruction Manual*  
*Bedienungsanleitung*  
*Manuel d'utilisation*  
*Manuale di Istruzioni*

**AS3X**<sup>®</sup> 

**Bind-N-Fly**<sup>®</sup>  
BASIC

**NOTICE**

All instructions, warranties and other collateral documents are subject to change at the sole discretion of Horizon Hobby, LLC. For up-to-date product literature, visit [www.horizonhobby.com](http://www.horizonhobby.com) and click on the support tab for this product.

**Meaning of Special Language:**

The following terms are used throughout the product literature to indicate various levels of potential harm when operating this product:

**NOTICE:** Procedures, which if not properly followed, create a possibility of physical property damage AND little or no possibility of injury.

**CAUTION:** Procedures, which if not properly followed, create the probability of physical property damage AND a possibility of serious injury.

**WARNING:** Procedures, which if not properly followed, create the probability of property damage, collateral damage, and serious injury OR create a high probability of superficial injury.



**WARNING:** Read the ENTIRE instruction manual to become familiar with the features of the product before operating. Failure to operate the product correctly can result in damage to the product, personal property and cause serious injury.

This is a sophisticated hobby product. It must be operated with caution and common sense and requires some basic mechanical ability. Failure to operate this Product in a safe and responsible manner could result in injury or damage to the product or other property. This product is not intended for use by children without direct adult supervision. Do not use with incompatible components or alter this product in any way outside of the instructions provided by Horizon Hobby, LLC. This manual contains instructions for safety, operation and maintenance. It is essential to read and follow all the instructions and warnings in the manual, prior to assembly, setup or use, in order to operate correctly and avoid damage or serious injury.

**14+**

**AGE RECOMMENDATION:**  
Not for children under 14  
years. This is not a toy.



**WARNING AGAINST COUNTERFEIT PRODUCTS:** If you ever need to replace your Spektrum receiver found in a Horizon Hobby product, always purchase from Horizon Hobby, LLC or a Horizon Hobby authorized dealer to ensure authentic high-quality Spektrum product. Horizon Hobby, LLC disclaims all support and warranty with regards, but not limited to, compatibility and performance of counterfeit products or products claiming compatibility with DSM or Spektrum.

## Safety Precautions and Warnings

As the user of this product, you are solely responsible for operating in a manner that does not endanger yourself and others or result in damage to the product or the property of others.

- Always keep a safe distance in all directions around your model to avoid collisions or injury. This model is controlled by a radio signal subject to interference from many sources outside your control. Interference can cause momentary loss of control.
- Always operate your model in open spaces away from full-size vehicles, traffic and people.
- Always carefully follow the directions and warnings for this and any optional support equipment (chargers, rechargeable battery packs, etc.).
- Always keep all chemicals, small parts and anything electrical out of the reach of children.
- Always avoid water exposure to all equipment not specifically designed and

protected for this purpose. Moisture causes damage to electronics.





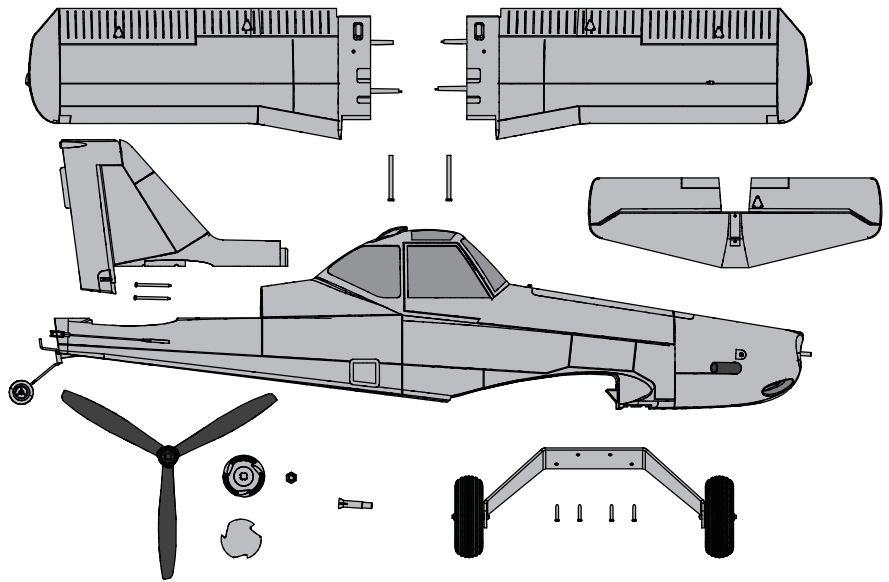

- Never place any portion of the model in your mouth as it could cause serious injury or even death.
- Never operate your model with low transmitter batteries.
- Always keep aircraft in sight and under control.
- Always use fully charged batteries.
- Always keep transmitter powered on while aircraft is powered.
- Always remove batteries before disassembly.
- Always keep moving parts clean.
- Always keep parts dry.
- Always let parts cool after use before touching.
- Always remove batteries after use.
- Always ensure failsafe is properly set before flying.
- Never operate aircraft with damaged wiring.
- Never touch moving parts.

## Box Contents

| Quick Start Information       |   |                  |                  |
|-------------------------------|---|------------------|------------------|
| <b>Transmitter Setup</b>      | Set up your transmitter using the transmitter setup chart |                  |                  |
| <b>Dual Rates</b>             |   | <b>Hi Rate</b>   | <b>Low Rate</b>  |
|                               | Ail   | ▲=15mm<br>▼=10mm | ▲=10mm<br>▼=08mm |
|                               | Ele   | ▲=15mm<br>▼=10mm | ▲=12mm<br>▼=9mm  |
|                               | Rud   | ▶=18mm<br>◀=18mm | ▶=10mm<br>◀=10mm |
| Flaps                         | Full<br>▼=30mm  | Half<br>▼=15mm   |                  |
| <b>Center of Gravity (CG)</b> | 89mm back from leading edge at the root.                  |                  |                  |
| <b>Flight Timer Setting</b>   | 5-7 minutes   |                  |                  |



## Specifications

|   |   | <b>BNF BASIC</b>            |
|---|---|-----------------------------|
|  | <b>Motor:</b> BL15 750Kv Outrunner motor (EFLM1600)   | <b>Installed</b>            |
|  | <b>ESC:</b> 30A Brushless ESC (EFLA1031)  | <b>Installed</b>            |
|  | <b>Servo:</b> 9 Gram servo (SPMSA330)   | <b>Installed</b>            |
|  | <b>Receiver:</b> Spektrum™ AR636A 6-Channel Sport Receiver (SP-MAR636)  | <b>Installed</b>            |
|  | <b>Recommended Battery:</b> 11.1V 3S 2200mAh 30C Li-Po (EFLB22003S30)   | <b>Required to Complete</b> |
|  | <b>Recommended Battery Charger:</b> 3-cell Li-Po battery balancing charger  | <b>Required to Complete</b> |
|  | <b>Recommended Transmitter:</b> Full-Range 6 channel (or more) 2.4GHz with Spektrum™ DSM2®/DSMX® technology with adjustable Dual Rates. | <b>Required to Complete</b> |

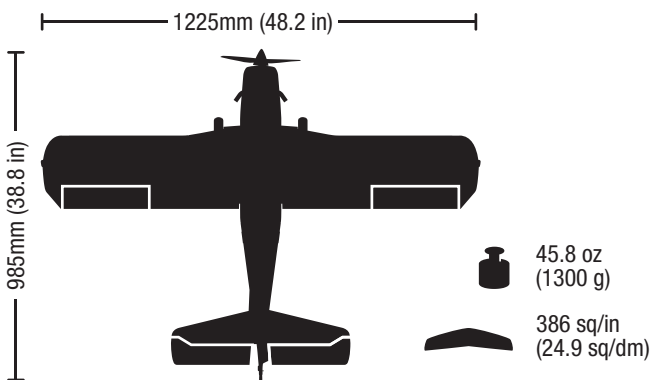

## Table of Contents

|  |    |
|--|----|
| Preflight.....                                     | 4  |
| Transmitter Setup .....                            | 4  |
| Model Assembly .....                               | 5  |
| Control Horn and Servo Arm Settings .....          | 10 |
| Transmitter and Receiver Binding.....              | 10 |
| Battery Installation and ESC Arming.....           | 11 |
| Center of Gravity (CG) .....                       | 12 |
| AS3X Control Direction Test .....                  | 12 |
| In Flight Trimming .....                           | 13 |
| Flying Tips and Repairs.....                       | 13 |
| Post Flight .....                                  | 14 |
| Troubleshooting Guide AS3X .....                   | 14 |
| Troubleshooting Guide .....                        | 15 |
| AMA National Model Aircraft Safety Code.....       | 16 |
| Limited Warranty .....                             | 17 |
| Contact Information .....                          | 18 |
| FCC Information.....                               | 18 |
| IC Information.....                                | 18 |
| Compliance Information for the European Union..... | 18 |
| Replacement Parts.....                             | 66 |
| Optional Parts.....                                | 66 |

To register your product online, visit [www.e-fliterc.com](http://www.e-fliterc.com)

## Preflight

|   |  |
|---|--|
| 1 | Remove and inspect contents.   |
| 2 | Read this instruction manual thoroughly.                                     |
| 3 | Charge the flight battery.   |
| 4 | Setup Transmitter using transmitter setup chart.                             |
| 5 | Fully assemble the airplane.   |
| 6 | Install the flight battery in the aircraft (once it has been fully charged). |
| 7 | Check the Center of Gravity (CG).  |
| 8 | Bind the aircraft to your transmitter.                                       |
| 9 | Make sure linkages move freely.  |

|    |  |
|----|--|
| 10 | Test the flap operation.                                   |
| 11 | Perform the Control Direction Test with the transmitter.   |
| 12 | Perform the AS3X Control Direction Test with the aircraft. |
| 13 | Adjust flight controls and transmitter.                    |
| 14 | Perform a radio system Range Test.                         |
| 15 | Find a safe open area to fly.                              |
| 16 | Plan flight for flying field conditions.                   |

## Transmitter Setup

**IMPORTANT:** After you set up your model, always rebind the transmitter and receiver to set the desired failsafe positions.

### Dual Rates

Take first flights in Low Rate. For landings, use high rate elevator.

**NOTICE:** To ensure AS3X® functions properly, do not lower rate values below 50%. If lower rates are desired, manually adjust the position of the pushrods on the servo arm.

**NOTICE:** If oscillation occurs at high speed, refer to the Troubleshooting Guide for more information.

### Expo

Expo is factory set in the receiver. After first flights, you may adjust expo in your transmitter or refer to the AR636 receiver manual for expo adjustment.

### Computerized Transmitter Setup

(DX6i, DX6, DX7, DX7S, DX8, DX9, DX10t and DX18)

Start all transmitter programming with a blank ACRO model (do a model reset), then name the model.

|                                    |   |
|------------------------------------|---|
| Set Dual Rates to:                 | HIGH 100%   |
|                                    | LOW 70%   |
| Set Servo Travel to:               | 100%  |
| DX6i                               | 1. Go to the SETUP LIST MENU  |
|                                    | 2. Set MODEL TYPE: ACRO   |
|                                    | 3. Go to ADJUST LIST MENU   |
|                                    | 4. Set FLAPS: Norm ↑ 100 Flap and 0 ELEV<br>LAND ↓ 80 Flap and ↑ 10 ELEV  |
| DX7S<br>DX8                        | 1. Go to the SYSTEM SETUP   |
|                                    | 2. Set MODEL TYPE: AIRPLANE   |
|                                    | 3. Set WING TYPE: 1 AIL 1 FLAP  |
|                                    | 4. Go to the FUNCTION LIST  |
|                                    | 5. Set FLAP SYSTEM: Choose Flap<br>NORM: -100% FLAP and 0% ELEV<br>MID: -30% FLAP and -3% ELEV<br>LAND: 80% FLAP and -10% ELEV<br>SPEED 2.0S: SWITCH = FLAP |
| DX6<br>DX7<br>DX9<br>DX10t<br>DX18 | 1. Go to the SYSTEM SETUP   |
|                                    | 2. Set MODEL TYPE: AIRPLANE   |
|                                    | 3. Set AIRCRAFT TYPE:<br>WING: 1 AIL 1 FLAP   |
|                                    | 4. Go to the FUNCTION LIST  |
|                                    | 5. Set FLAP SYSTEM:<br>SELECT SWITCH D:<br>POS 0: -100% FLAP and 0% ELEV<br>POS 1: -30% FLAP and -3% ELEV<br>POS 2: 80% FLAP and -10% ELEV<br>SPEED 2.0     |



## Model Assembly

### Main Gear Installation

Secure the main gear assembly to the fuselage using 4 screws (A).

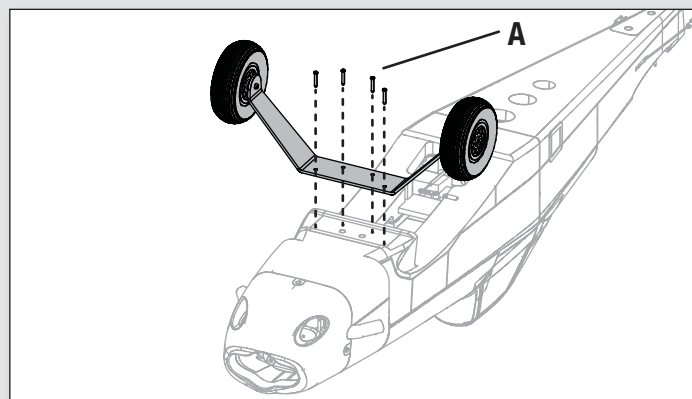

### Tail Installation

1. Connect the light connector (Servo style) from the horizontal stab to the fuselage.
2. Install the horizontal stab to the fuselage with the control horn facing down.
3. Connect the internal light connector (JST style) from the vertical fin to the connector coming from the top of the horizontal stab.
4. Align the vertical fin to the top of the horizontal stab.
5. Secure the tail assembly to the fuselage with the included 2 screws (A) as shown.
6. Connect the rudder control horn to the respective clevis (B) as shown.
7. Connect the elevator control horn to the respective clevis (C) as shown.

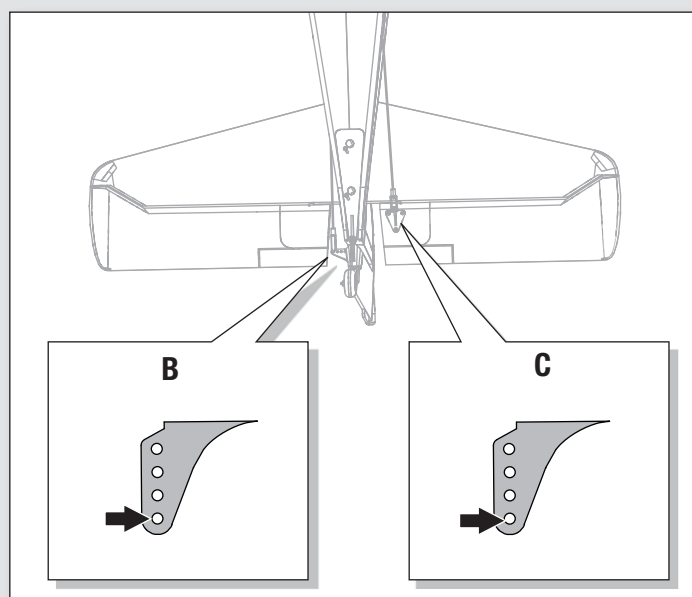
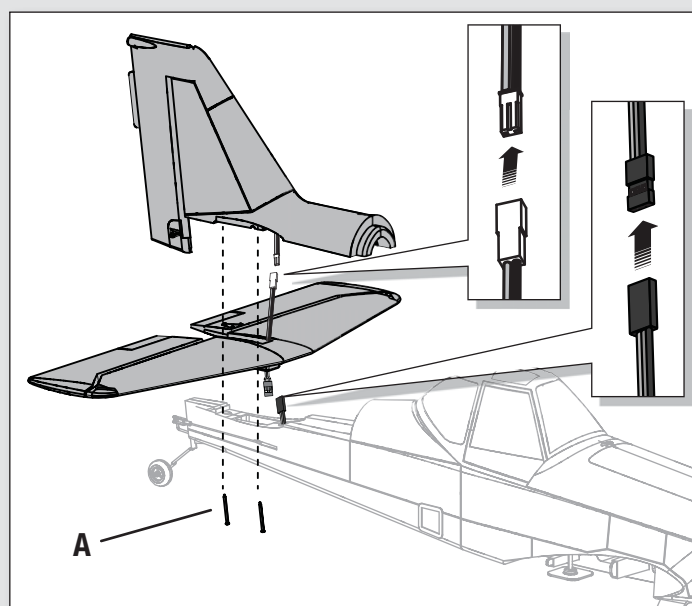

## Model Assembly *Continued*

### Wing assembly

1. Slide the left and right wing halves together, as shown (figure A).
2. Ensure the internal wing lights connectors (JST type connector), aileron servo connectors and navigation light connectors are aligned with the hole (B) created by the two connected wing halves.

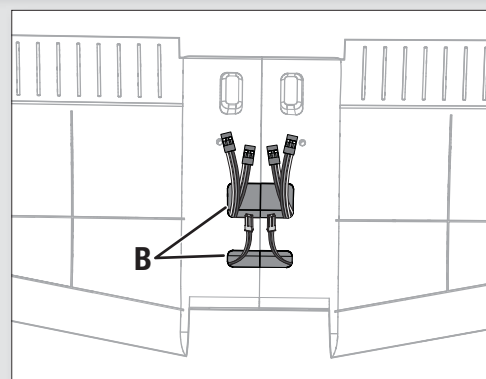
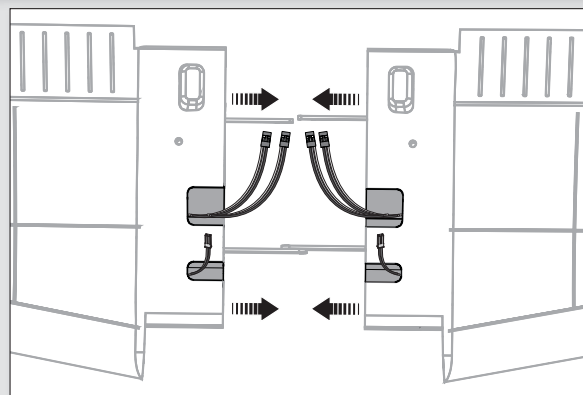
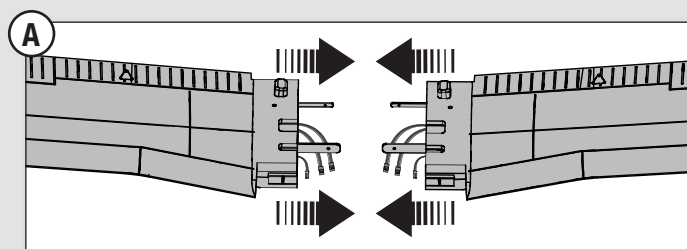

### Wing Installation

1. Remove the battery hatch by pushing the retaining latch forward and pulling up on the backside of the hatch.

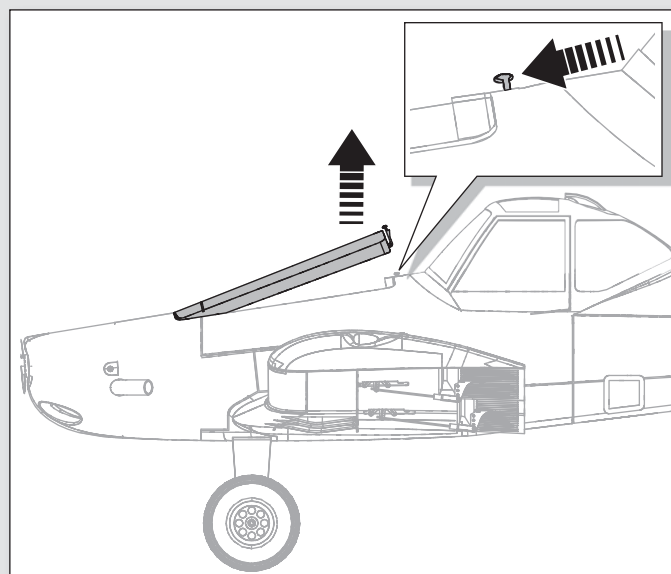

Continued →

## Model Assembly *Continued*

### Wing Installation

2. Guide the aileron servo connectors, wing light and navigation light connectors (A) from the wing through the hole in the bottom side of the fuselage.

**IMPORTANT:** The ailerons must be connected to the receiver's AILE (#2 channel) with a Y-harness (included) for the AS3X® system to function properly.

3. Mount the wing by aligning the 4 wing pins with the respective holes of the fuselage.
4. Secure the wing into position using the included 2 screws (B).

**⚠ CAUTION:** DO NOT crush or otherwise damage the wiring when attaching the wing to the fuselage.

5. Flip the plane over onto its landing gear to gain access through the battery hatch opening.
6. Connect the aileron servo connectors (C) to the receiver using the pre-installed Y-harness as shown. The left and right servos can be connected to either side of a Y-harness.
7. Connect the internal wing light connectors (red JST type connector) to the light harness (D).
8. Connect the navigation light connectors (servo style connector with only 2 wires) to the light controller (E) located next to the receiver. Make sure to connect the connector with the black wire facing up.
9. Reinstall the canopy hatch on the fuselage.

Disassemble in reverse order.

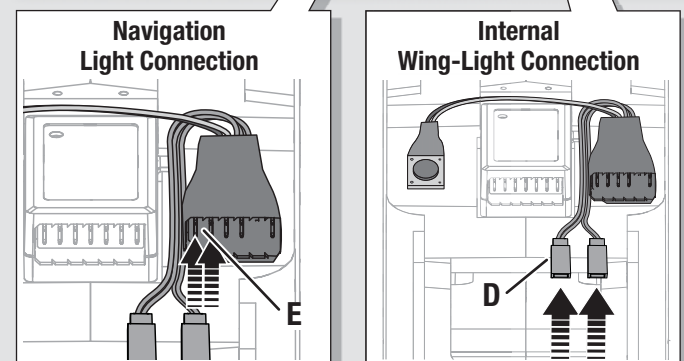
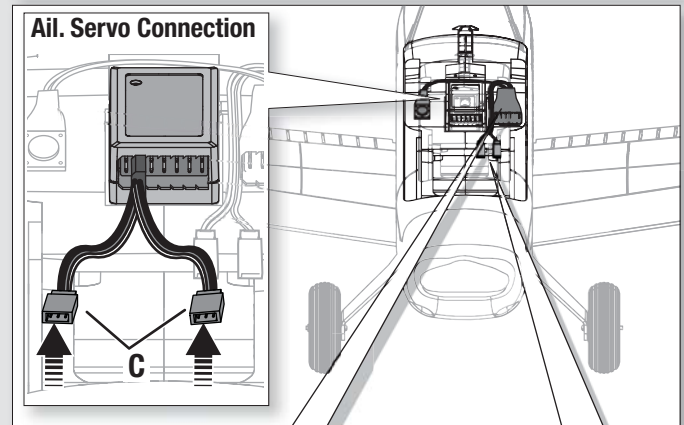
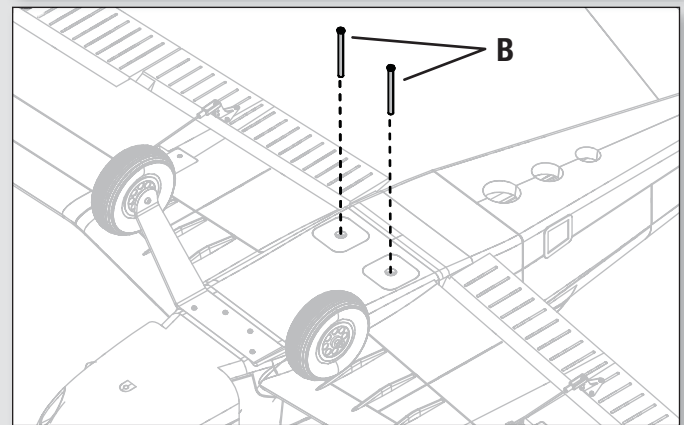
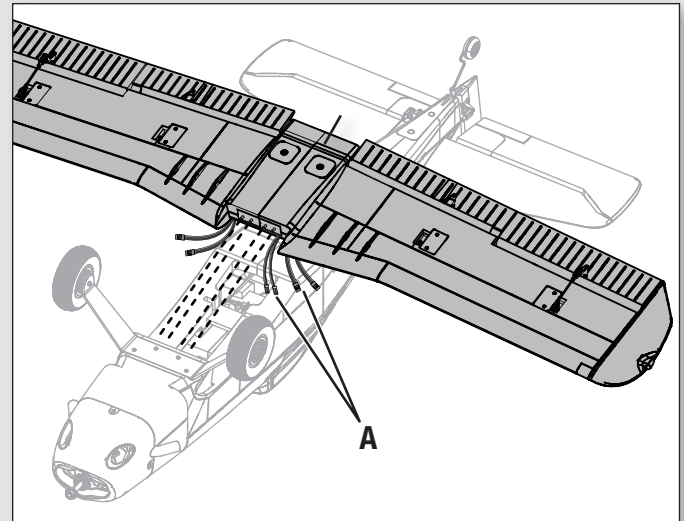

### Powering on the lights

1. Power ON and OFF the lights by pushing the button (F) left of the receiver.

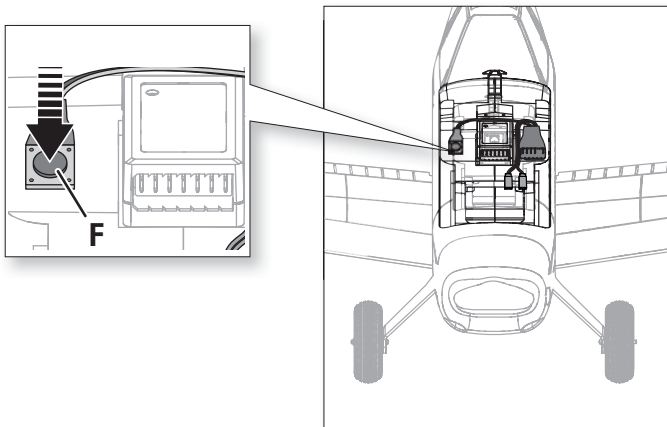

## Model Assembly *Continued*

### Clevis Installation

- Pull the tube from the clevis to the linkage.
- Carefully spread the clevis, then insert the clevis pin into the desired hole in the control horn.
- Move the tube to hold the clevis on the control horn.

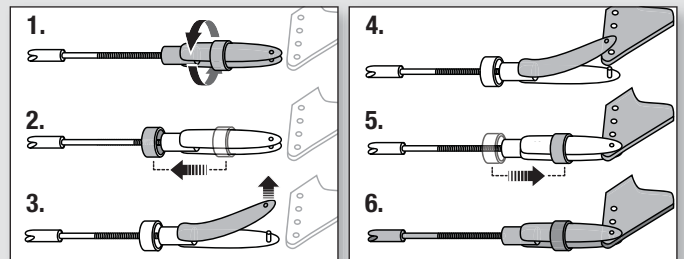

### Control Surface Centering

After assembly and transmitter setup, confirm that the control surfaces are centered. If the control surfaces are not centered, mechanically center the control surfaces by adjusting the linkages.

If adjustment is required, turn the clevis on the linkage to change the length of the linkage between the servo arm and the control horn.

After binding a transmitter to the aircraft receiver, set the trims and sub-trims to 0, then adjust the clevises to center the control surfaces.

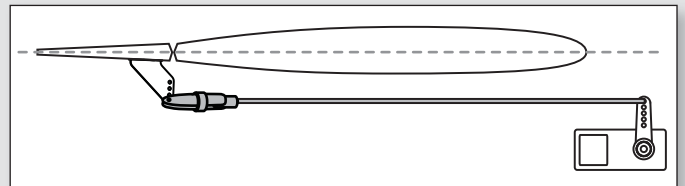

### Propeller Installation

1. Install the collet (A), backplate (B), spinner backplate (C) and propeller (D) onto the motor shaft (E).
2. Secure the propeller into place using the washer (F) and spinner nut (G).

**IMPORTANT:** Ensure that the propeller size numbers (10 x 8) are facing towards the rear of the aircraft.

3. Align the spinner and press it into place. It will snap into place with a little pressure.

When needed, remove the spinner by putting side force on the tip until it pops loose.

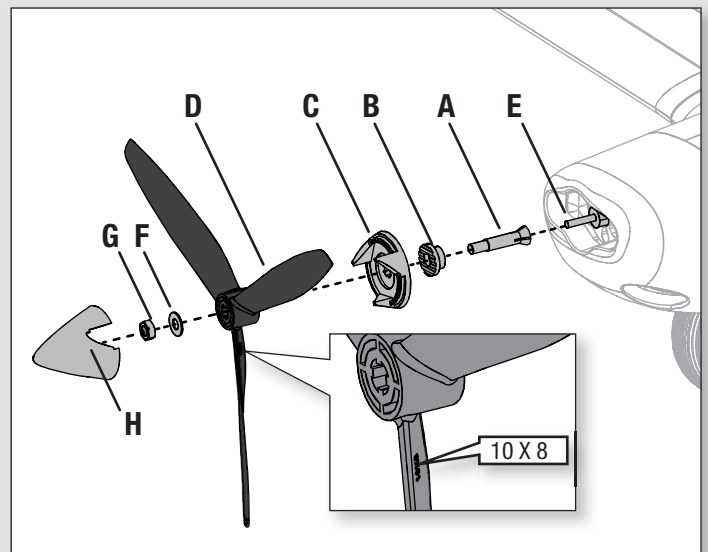

## Model Assembly *Continued*

### Optional Flap Installation

Before you begin you will need to purchase (2) (SPMA330) servos and a 6 inch Y-harness (SPMA3058) to complete the flap installation process.

1. Remove the main wing from the fuselage.
2. Install the servo arm included with the servos, angled rearward as shown (figure A).
3. Guide the servo wires down and through the wire channel of each wing.
4. Install the left and right flap servos (B) in the respective recess of the wing. Secure the servos into place using the servo plates (C) and screws (included with the aircraft) as shown.
5. Install the control horns (D) onto each wing using 2 screws as shown.
6. Connect the control rods (E) to the servo arms, and then from the servo arms to the control horns on each flap. Use the Control Horn and Servo Arm Settings chart on the next page for the recommend hole placement.
7. Carefully cut and remove a small amount of foam (F) at the flap and wing root to allow the flaps to move freely, as shown.
8. Carefully cut and remove a wedge of foam (G) from flap hinge near the aileron hinge as shown.
9. Repeat this process on the left wing.
10. Install the wings onto the fuselage and connect the newly installed flap servo connectors to the correct receiver channels or Y-harness.
11. Perform a control direction test of the flaps.

With the flap switch in the up position, flaps should be adjusted so they are even with the ailerons and/or the root of the wing.

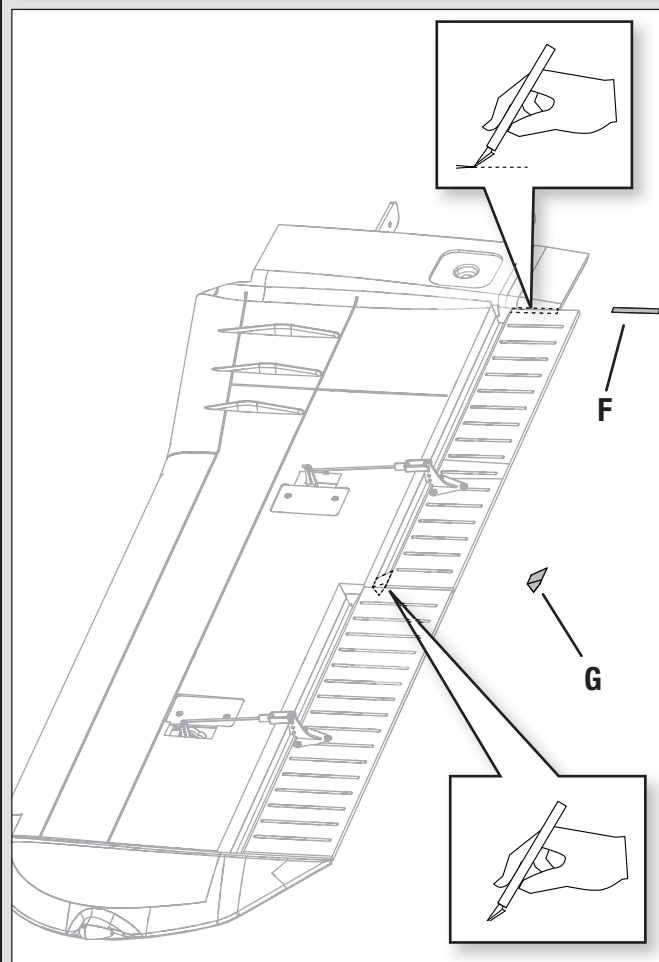
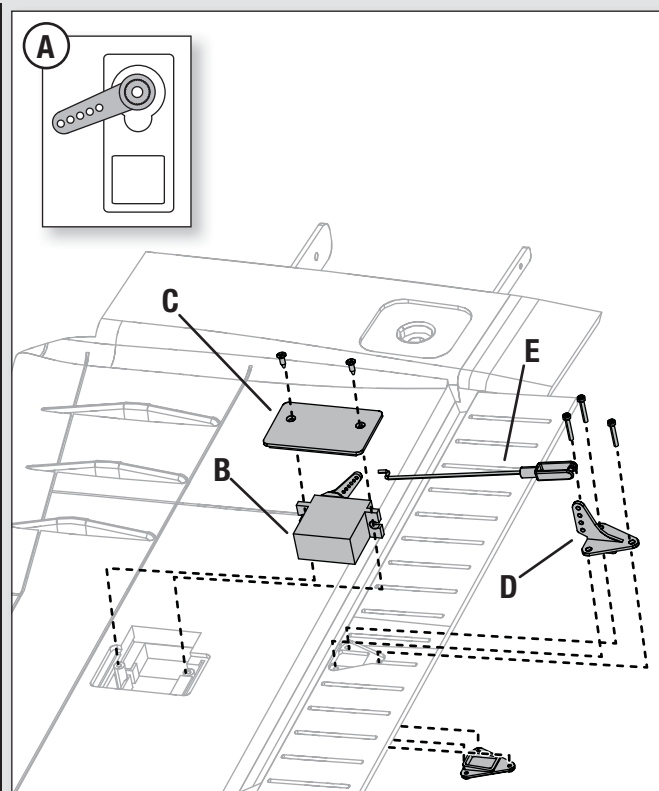

## Control Horn and Servo Arm Settings

The table to the right shows the factory settings for the control horns and servo arms. Fly the aircraft at factory settings before making changes.

**NOTICE:** If control throws are changed from the factory settings, the AR636 gain values may need to be adjusted. Refer to the Spektrum AR636 manual for adjustment of gain values.

After flying, you may choose to adjust the linkage positions for the desired control response. See the table to the right.

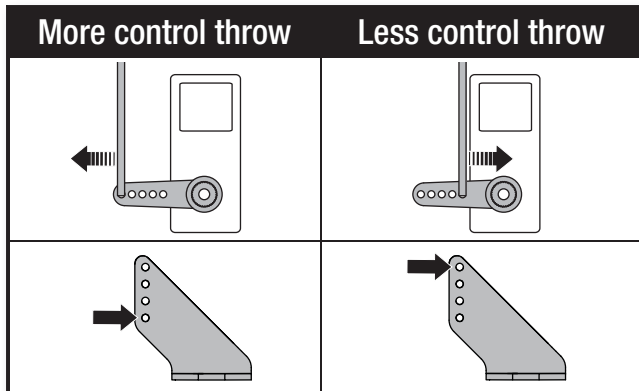

|          | Horns | Arms |
|----------|-------|------|
| Elevator |       |      |
| Ailerons |       |      |
| Rudder   |       |      |
| Flaps    |       |      |

## Transmitter and Receiver Binding

Binding is the process of programming the receiver to recognize the GUID (Globally Unique Identifier) code of a single specific transmitter. You need to 'bind' your chosen Spektrum™ DSM2®/DSMX® technology equipped aircraft transmitter to the receiver for proper operation.

**IMPORTANT:** Before binding a transmitter, read the Transmitter Setup section of this manual to ensure that your transmitter is properly programmed for this aircraft.

### Binding Procedure

**IMPORTANT:** The included AR636 receiver has been programmed for operation specifically for this aircraft. Refer to the receiver manual for correct setup if the receiver is replaced or is used in another aircraft.

Read the transmitter instructions for binding to a receiver (location of transmitter's Bind control). **Please visit [www.bindnfly.com](http://www.bindnfly.com) for a complete list of compatible transmitters.**

**CAUTION:** When using a Futaba® transmitter with a Spektrum DSM module, you must reverse the throttle channel and rebind. Refer to your Spektrum module manual for binding and failsafe instructions. Refer to your Futaba transmitter manual for instructions on reversing the throttle channel.

1. Make sure the transmitter is powered off.
2. Move the transmitter controls to neutral (flight controls: rudder, elevators and ailerons) or to low positions (throttle, throttle trim).\*\*
3. Install a bind plug in the receiver bind port.
4. Connect the flight battery to the ESC. The orange bind LED on the receiver will begin to flash rapidly. The ESC will produce a series of sounds, 3 ascending tones and 1 beep every two seconds indicating that it is searching for a transmitter bind signal.
5. Power on the transmitter while holding the transmitter bind button or switch. Refer to your transmitter's manual for binding.

6. When the receiver binds to the transmitter, the orange bind light on the receiver will turn solid and the ESC will produce 3 tones and then 1 slightly longer beep. The longer beep indicates the ESC is armed, provided the throttle stick and throttle trim are low enough to trigger arming.
7. Remove the bind plug from the bind port.
8. Safely store the bind plug (some owners attach the bind plug to their transmitter using two-part loops and clips).
9. The receiver should retain the binding instructions received from the transmitter until another binding is done.

\* The throttle will not arm if the transmitter's throttle control is not put at the lowest position. If you encounter problems, follow the binding instructions and refer to the transmitter troubleshooting guide for other instructions. If needed, contact the appropriate Horizon Product Support office.

### \*\*Failsafe

If the receiver loses transmitter communication, the failsafe will activate. When activated, the airplane controls return to the neutral position established during step 2 of the binding procedure.

### Bind Plug Installation

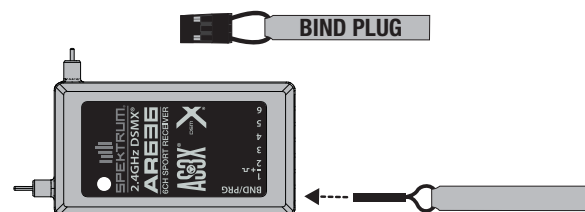

## Battery Installation and ESC Arming

### Battery Selection

We recommend the E-flite® 2200mAh 11.1V 3S 30C Li-Po battery (EFLB22003S30). Refer to the Optional Parts List for other recommended batteries. If using a battery other than those listed, the battery should be within the range of capacity, dimensions and weight of the E-flite Li-Po battery packs to fit in the fuselage. Be sure the model balances at the recommended CG.

1. Apply the loop side (soft side) of the hook and loop tape (A) to the bottom of your battery.
2. Lower the throttle and throttle trim to the lowest settings. Power on the Transmitter, then wait 5 seconds.
3. Carefully lift the back of the canopy hatch (B) to remove.
4. Install the fully charged battery (C) in the battery compartment as shown. See the *Adjusting the Center of Gravity* instructions for more information.
5. Make sure the flight battery is secured using the hook and loop strap (D).
6. Connect the battery to the ESC (the ESC is now armed).
7. Keep the aircraft immobile and away from wind or the system will not initialize.
  - The ESC will sound 3 tones (refer to step 6 of the binding instructions for more information).
  - An LED will light on the receiver.

If the ESC sounds only a double beep after the flight battery is connected, recharge or replace the battery.

8. Reinstall the canopy hatch.

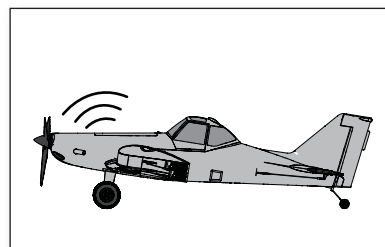
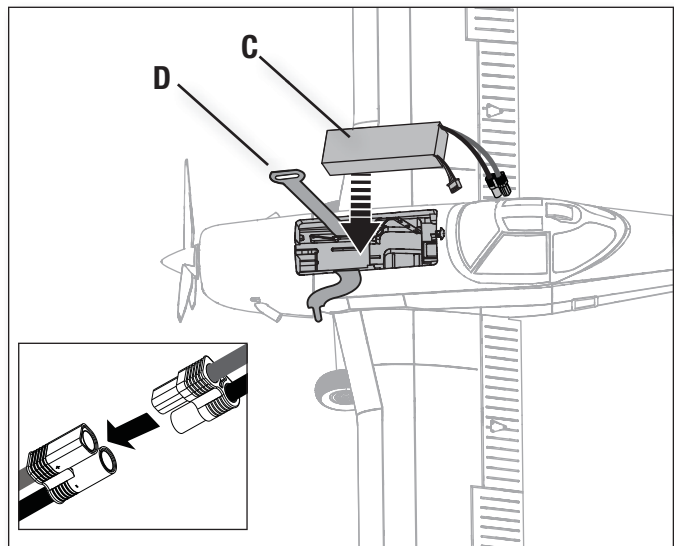
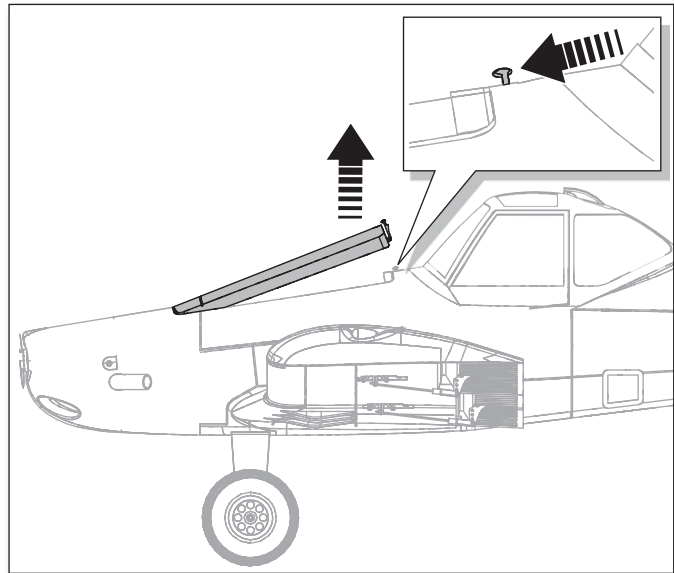
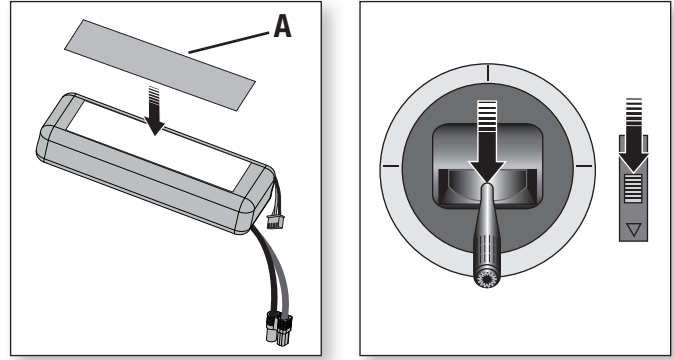

**CAUTION:** Always keep hands away from the propeller. When armed, the motor will turn the propeller in response to any throttle movement.



## Center of Gravity (CG)

The CG location is measured from the leading edge of the wing at the root. This CG location has been determined with the recommended Li-Po battery (EFLB22003S30) installed all the way forward in the battery compartment.

The easiest way to achieve CG is to balance the aircraft inverted.

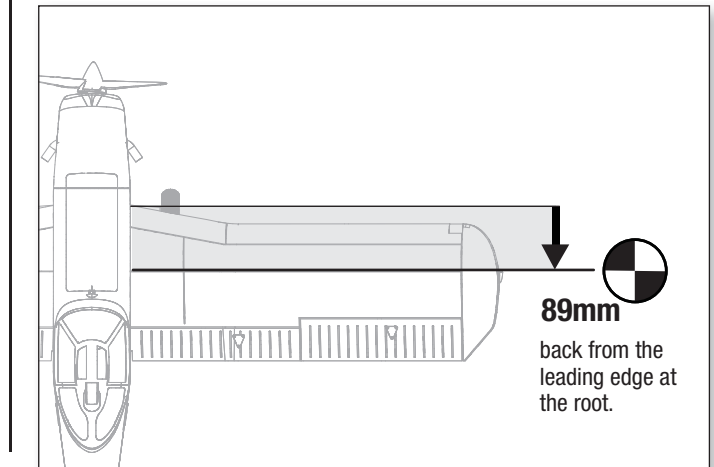

## AS3X Control Direction Test

This test ensures that the AS3X® control system is functioning properly. Assemble the aircraft and bind your transmitter to the receiver before performing this test.

1. Raise the throttle just above 25%, then lower the throttle to activate AS3X.

**CAUTION:** Keep all body parts, hair and loose clothing away from a moving propeller, as these items could become entangled.

2. Move the entire aircraft as shown and ensure the control surfaces move in the direction indicated in the graphic. If the control surfaces do not respond as shown, do not fly the aircraft. Refer to the receiver manual for more information.

Once the AS3X system is active, control surfaces may move rapidly. This is normal. AS3X technology remains active until the battery is disconnected.

|          | Aircraft movement | AS3X Reaction |
|----------|-------------------|---------------|
| Elevator |                   |               |
|          |                   |               |
| Aileron  |                   |               |
|          |                   |               |
| Rudder   |                   |               |
|          |                   |               |



## In Flight Trimming

During your first flight, trim the aircraft for level flight at 3/4 throttle. Make small trim adjustments with your transmitter's trim switches to straighten the aircraft's flight path.

After adjusting trim **do not touch the control sticks for 3 seconds**. This allows the receiver to learn the correct settings to optimize AS3X performance.

Failure to do so could affect flight performance.

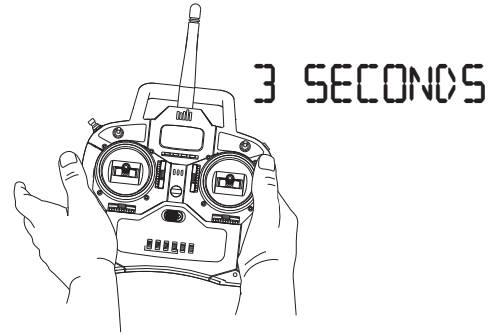

## Flying Tips and Repairs

Consult local laws and ordinances before choosing a flying location.

### Flying Field

Always choose a wide-open space for flying your aircraft. It is recommended that you fly at a designated RC flying field. Always avoid flying near houses, trees, wires and buildings. Avoid flying in areas where there are many people, such as parks, schoolyards, or soccer fields.

### Range Check your Radio System

Before you fly, range check the radio system. Refer to your specific transmitter instruction manual for range test information.

### Oscillation

Once the AS3X system is active (after advancing the throttle for the first time), you will normally see the control surfaces react to aircraft movement. In some flight conditions you may see oscillation (the aircraft rocks back and forth on one axis due to overcontrol). If oscillation occurs, refer to the Troubleshooting Guide for more information.

### Takeoff

Place the aircraft facing into the wind. Set your transmitter in low rate and use your flaps switch to drop the flaps to takeoff or "half position". Gradually increase the throttle to 3/4 and steer with the rudder. **Flaps make takeoffs shorter**. As the tail comes off the ground, pull back gently on the elevator. Climb to a comfortable altitude and then flip your flaps switch to level the flaps.

### Flying

Fly the airplane and trim it for level flight at 3/4 throttle with flaps up. After adjusting trim in flight do not touch the control sticks for 3 seconds. This allows the receiver to learn the correct settings to optimize AS3X performance.

### Landing

For your first flights with the recommended battery pack (EFLB22003S30), set your transmitter timer or a stopwatch to 5 minutes. After five minutes, land the aircraft. Adjust your timer for longer or shorter flights once you have flown the model. **If at any time the motor pulses, land the aircraft immediately to recharge the flight battery**. See the Low Voltage Cutoff (LVC) section for more details on maximizing battery health and run time.

Land the aircraft into the wind. Use high rate Elevator for landings. Use a small amount of throttle for the entire descent. Lower the throttle to 1/4 and flip your flaps switch to deploy the flaps to the landing or "full down position". **Flaps will make the landing approach steeper and slower, and allow for a smoother landing**.

Keep the throttle on until the aircraft is ready to flare. During flare, keep the wings level and the aircraft pointed into the wind. Gently lower the throttle while pulling back on the elevator to bring the aircraft down on the front wheels (two point landing). The aircraft can also be landed on all three wheels

(three point landing). When the aircraft touches down, reduce back pressure on the elevator stick to keep the aircraft from becoming air born again.

If landing on grass, it is best to hold full up elevator after touchdown and when taxiing to prevent nosing over.

Once on the ground, avoid sharp turns until the plane has slowed enough to prevent scraping the wingtips.

**NOTICE:** If a crash is imminent, reduce the throttle and trim fully. Failure to do so could result in extra damage to the airframe, as well as damage to the ESC and motor.

**NOTICE:** After any impact, always ensure the receiver is secure in the fuselage. If you replace the receiver, install the new receiver in the same orientation as the original receiver or damage may result.

**NOTICE:** Crash damage is not covered under warranty.

**NOTICE:** When you are finished flying, never leave the aircraft in direct sunlight or in a hot, enclosed area such as a car. Doing so can damage the aircraft.

**WARNING:** Always decrease throttle at propeller strike.

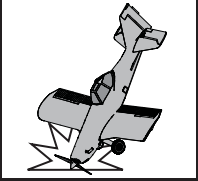

### Low Voltage Cutoff (LVC)

When a Li-Po battery is discharged below 3V per cell, it will not hold a charge. The ESC protects the flight battery from over-discharge using Low Voltage Cutoff (LVC). Before the battery charge decreases too much, LVC removes power supplied to the motor. Power to the motor pulses, showing that some battery power is reserved for flight control and safe landing.

Disconnect and remove the Li-Po battery from the aircraft after use to prevent trickle discharge. Charge your Li-Po battery to about half capacity before storage. During storage, make sure the battery charge does not fall below 3V per cell. LVC does not prevent the battery from over-discharge during storage.

**NOTICE:** Repeated flying to LVC will damage the battery.

**Tip:** Monitor your aircraft battery's voltage before and after flying by using a Li-Po Cell Voltage Checker (EFLA111, sold separately).

### Repairs

Thanks to the Z-Foam™ material in this aircraft, repairs to the foam can be made using virtually any adhesive (hot glue, regular CA, epoxy, etc). When parts are not repairable, see the Replacement Parts List for ordering by item number. For a listing of all replacement and optional parts, refer to the list at the end of this manual.

**NOTICE:** Use of CA accelerant on your aircraft can damage paint. DO NOT handle the aircraft until accelerant fully dries.

## Post Flight

|   |  |   |  |
|---|--|---|--|
| 1 | Disconnect the flight battery from the ESC (Required for Safety and battery life). | 5 | Repair or replace all damaged parts.   |
| 2 | Power OFF the transmitter.   | 6 | Store the flight battery apart from the aircraft and monitor the battery charge.         |
| 3 | Remove the flight battery from the aircraft.                                       | 7 | Make note of the flight conditions and flight plan results, planning for future flights. |
| 4 | Recharge the flight battery.   |   |  |

## Troubleshooting Guide AS3X

| Problem   | Possible Cause   | Solution   |
|---|--|--|
| Oscillation   | Damaged propeller or spinner   | Replace propeller or spinner   |
|   | Imbalanced propeller   | Balance the propeller. For more information, view our propeller balancing video on Horizon Hobby's YouTube channel <a href="https://www.youtube.com/watch?v=OXuNnYQO2s4">https://www.youtube.com/watch?v=OXuNnYQO2s4</a> |
|   | Motor vibration  | Replace parts or correctly align all parts and tighten fasteners as needed   |
|   | Loose receiver   | Align and secure receiver in fuselage  |
|   | Loose aircraft controls  | Tighten or otherwise secure parts (servo, arm, linkage, horn and control surface)  |
|   | Worn parts   | Replace worn parts (especially propeller, spinner or servo)  |
|   | Irregular servo movement   | Replace servo  |
| Inconsistent flight performance                       | Trim is not at neutral   | If you adjust trim more than 8 clicks, adjust the clevis to remove trim  |
|   | Sub-Trim is not at neutral   | No Sub-Trim is allowed. Adjust the servo linkage   |
|   | Aircraft was not kept immobile for 5 seconds after battery connection. | With the throttle stick in lowest position. Disconnect battery, then reconnect battery and keep the aircraft still for 5 seconds   |
| Incorrect response to the AS3X Control Direction Test | Incorrect direction settings in the receiver, which can cause a crash  | DO NOT fly. Correct the direction settings (refer to the receiver manual), then fly  |

## Troubleshooting Guide

| Problem  | Possible Cause   | Solution  |
|--|--|---|
| Aircraft will not respond to throttle but responds to other controls | Throttle not at idle and/or throttle trim too high   | Reset controls with throttle stick and throttle trim at lowest setting  |
|  | Throttle servo travel is lower than 100%   | Make sure throttle servo travel is 100% or greater  |
|  | Throttle channel is reversed   | Reverse throttle channel on transmitter   |
|  | Motor disconnected from ESC  | Make sure motor is connected to the ESC   |
| Extra propeller noise or extra vibration                             | Damaged propeller and spinner, collet or motor   | Replace damaged parts   |
|  | Propeller is out of balance  | Balance or replace propeller  |
|  | Prop nut is too loose  | Tighten the prop nut  |
|  | Spinner is not tight or fully seated in place  | Inspect spinner to ensure it is fully seated  |
| Reduced flight time or aircraft under-powered                        | Flight battery charge is low   | Completely recharge flight battery  |
|  | Propeller installed backwards  | Install propeller with numbers facing forward   |
|  | Flight battery damaged   | Replace flight battery and follow flight battery instructions   |
|  | Flight conditions may be too cold  | Make sure battery is warm before use  |
|  | Battery capacity too low for flight conditions   | Replace battery or use a larger capacity battery  |
| Aircraft will not Bind (during binding) to transmitter               | Transmitter too near aircraft during binding process   | Move powered transmitter a few feet from aircraft, disconnect and reconnect flight battery to aircraft        |
|  | Aircraft or transmitter is too close to large metal object, wireless source or another transmitter | Move aircraft and transmitter to another location and attempt binding again                                   |
|  | The bind plug is not installed correctly in the bind port  | Install bind plug in bind port and bind the aircraft to the transmitter                                       |
|  | Flight battery/transmitter battery charge is too low   | Replace/recharge batteries  |
|  | Bind switch or button not held long enough during bind process                                     | Power off transmitter and repeat bind process. Hold transmitter bind button or switch until receiver is bound |
| Aircraft will not connect (after binding) to transmitter             | Transmitter too near aircraft during connecting process  | Move powered transmitter a few feet from aircraft, disconnect and reconnect flight battery to aircraft        |
|  | Aircraft or transmitter is too close to large metal object, wireless source or another transmitter | Move aircraft and transmitter to another location and attempt connecting again                                |
|  | Bind plug left installed in bind port  | Rebind transmitter to the aircraft and remove the bind plug before cycling power                              |
|  | Aircraft bound to different model memory (ModelMatch™ radios only)                                 | Select correct model memory on transmitter  |
|  | Flight battery/Transmitter battery charge is too low   | Replace/recharge batteries  |
|  | Transmitter may have been bound to a different aircraft using different DSM protocol               | Bind aircraft to transmitter  |
| Control surface does not move  | Control surface, control horn, linkage or servo damage   | Replace or repair damaged parts and adjust controls   |
|  | Wire damaged or connections loose  | Do a check of wires and connections, connect or replace as needed   |
|  | Transmitter is not bound correctly or the incorrect airplanes was selected                         | Re-bind or select correct airplanes in transmitter  |
|  | Flight battery charge is low   | Fully recharge flight battery   |
|  | BEC (Battery Elimination Circuit) of the ESC is damaged  | Replace ESC   |
| Controls reversed  | Transmitter settings are reversed  | Perform the Control Direction Test and adjust the controls on transmitter appropriately                       |
| Motor power pulses then motor loses power                            | ESC uses default soft Low Voltage Cutoff (LVC)   | Recharge flight battery or replace battery that is no longer performing                                       |
|  | Weather conditions might be too cold   | Postpone flight until weather is warmer   |
|  | Battery is old, worn out, or damaged   | Replace battery   |
|  | Battery C rating might be too small  | Use recommended battery   |

# AMA National Model Aircraft Safety Code

Effective January 1, 2014

## A. GENERAL

A model aircraft is a non-human-carrying aircraft capable of sustained flight in the atmosphere. It may not exceed limitations of this code and is intended exclusively for sport, recreation, education and/or competition. All model flights must be conducted in accordance with this safety code and any additional rules specific to the flying site.

1. Model aircraft will not be flown:
  - (a) In a careless or reckless manner.
  - (b) At a location where model aircraft activities are prohibited.
2. Model aircraft pilots will:
  - (a) Yield the right of way to all man carrying aircraft.
  - (b) See and avoid all aircraft and a spotter must be used when appropriate. (AMA Document #540-D.)
  - (c) Not fly higher than approximately 400 feet above ground level within three (3) miles of an airport, without notifying the airport operator.
  - (d) Not interfere with operations and traffic patterns at any airport, heliport or seaplane base except where there is a mixed use agreement.
  - (e) Not exceed a takeoff weight, including fuel, of 55 pounds unless in compliance with the AMA Large Model Aircraft program. (AMA Document 520-A.)
  - (f) Ensure the aircraft is identified with the name and address or AMA number of the owner on the inside or affixed to the outside of the model aircraft. (This does not apply to model aircraft flown indoors).
  - (g) Not operate aircraft with metal-blade propellers or with gaseous boosts except for helicopters operated under the provisions of AMA Document #555.
  - (h) Not operate model aircraft while under the influence of alcohol or while using any drug which could adversely affect the pilot's ability to safely control the model.
  - (i) Not operate model aircraft carrying pyrotechnic devices which explode or burn, or any device which propels a projectile or drops any object that creates a hazard to persons or property.
 

Exceptions:

    - Free Flight fuses or devices that burn producing smoke and are securely attached to the model aircraft during flight.
    - Rocket motors (using solid propellant) up to a G-series size may be used provided they remain attached to the model during flight. Model rockets may be flown in accordance with the National Model Rocketry Safety Code but may not be launched from model aircraft.
    - Officially designated AMA Air Show Teams (AST) are authorized to use devices and practices as defined within the Team AMA Program Document (AMA Document #718).
  - (j) Not operate a turbine-powered aircraft, unless in compliance with the AMA turbine regulations. (AMA Document #510-A).
3. Model aircraft will not be flown in AMA sanctioned events, air shows or model demonstrations unless:
  - (a) The aircraft, control system and pilot skills have successfully demonstrated all maneuvers intended or anticipated prior to the specific event.
  - (b) An inexperienced pilot is assisted by an experienced pilot.
4. When and where required by rule, helmets must be properly worn and fastened. They must be OSHA, DOT, ANSI, SNELL or NOCSAE approved or comply with comparable standards.

## B. RADIO CONTROL

1. All pilots shall avoid flying directly over unprotected people, vessels, vehicles or structures and shall avoid endangerment of life and property of others.
2. A successful radio equipment ground-range check in accordance with manufacturer's recommendations will be completed before the first flight of a new or repaired model aircraft.
3. At all flying sites a safety line(s) must be established in front of which all flying takes place (AMA Document #706.)
  - (a) Only personnel associated with flying the model aircraft are allowed at or in front of the safety line.
  - (b) At air shows or demonstrations, a straight safety line must be established.
  - (c) An area away from the safety line must be maintained for spectators.
  - (d) Intentional flying behind the safety line is prohibited.
4. RC model aircraft must use the radio-control frequencies currently allowed by the Federal Communications Commission (FCC). Only individuals properly licensed by the FCC are authorized to operate equipment on Amateur Band frequencies.
5. RC model aircraft will not operate within three (3) miles of any pre-existing flying site without a frequency-management agreement (AMA Documents #922 and #923.)
6. With the exception of events flown under official AMA Competition Regulations, excluding takeoff and landing, no powered model may be flown outdoors closer than 25 feet to any individual, except for the pilot and the pilot's helper(s) located at the flight line.
7. Under no circumstances may a pilot or other person touch a model aircraft in flight while it is still under power, except to divert it from striking an individual.
8. RC night flying requires a lighting system providing the pilot with a clear view of the model's attitude and orientation at all times. Hand-held illumination systems are inadequate for night flying operations.
9. The pilot of a RC model aircraft shall:
  - (a) Maintain control during the entire flight, maintaining visual contact without enhancement other than by corrective lenses prescribed for the pilot.
  - (b) Fly using the assistance of a camera or First-Person View (FPV) only in accordance with the procedures outlined in AMA Document #550.
  - (c) Fly using the assistance of autopilot or stabilization system only in accordance with the procedures outlined in AMA Document #560.

Please see your local or regional modeling association's guidelines for proper, safe operation of your model aircraft.

## Limited Warranty

### What this Warranty Covers

Horizon Hobby, LLC, (Horizon) warrants to the original purchaser that the product purchased (the "Product") will be free from defects in materials and workmanship at the date of purchase.

### What is Not Covered

This warranty is not transferable and does not cover (i) cosmetic damage, (ii) damage due to acts of God, accident, misuse, abuse, negligence, commercial use, or due to improper use, installation, operation or maintenance, (iii) modification of or to any part of the Product, (iv) attempted service by anyone other than a Horizon Hobby authorized service center, (v) Product not purchased from an authorized Horizon dealer, or (vi) Product not compliant with applicable technical regulations, or (vii) use that violates any applicable laws, rules, or regulations.

OTHER THAN THE EXPRESS WARRANTY ABOVE, HORIZON MAKES NO OTHER WARRANTY OR REPRESENTATION, AND HEREBY DISCLAIMS ANY AND ALL IMPLIED WARRANTIES, INCLUDING, WITHOUT LIMITATION, THE IMPLIED WARRANTIES OF NON-INFRINGEMENT, MERCHANTABILITY AND FITNESS FOR A PARTICULAR PURPOSE. THE PURCHASER ACKNOWLEDGES THAT THEY ALONE HAVE DETERMINED THAT THE PRODUCT WILL SUITABLY MEET THE REQUIREMENTS OF THE PURCHASER'S INTENDED USE.

### Purchaser's Remedy

Horizon's sole obligation and purchaser's sole and exclusive remedy shall be that Horizon will, at its option, either (i) service, or (ii) replace, any Product determined by Horizon to be defective. Horizon reserves the right to inspect any and all Product(s) involved in a warranty claim. Service or replacement decisions are at the sole discretion of Horizon. Proof of purchase is required for all warranty claims. SERVICE OR REPLACEMENT AS PROVIDED UNDER THIS WARRANTY IS THE PURCHASER'S SOLE AND EXCLUSIVE REMEDY.

### Limitation of Liability

HORIZON SHALL NOT BE LIABLE FOR SPECIAL, INDIRECT, INCIDENTAL OR CONSEQUENTIAL DAMAGES, LOSS OF PROFITS OR PRODUCTION OR COMMERCIAL LOSS IN ANY WAY, REGARDLESS OF WHETHER SUCH CLAIM IS BASED IN CONTRACT, WARRANTY, TORT, NEGLIGENCE, STRICT LIABILITY OR ANY OTHER THEORY OF LIABILITY, EVEN IF HORIZON HAS BEEN ADVISED OF THE POSSIBILITY OF SUCH DAMAGES. Further, in no event shall the liability of Horizon exceed the individual price of the Product on which liability is asserted. As Horizon has no control over use, setup, final assembly, modification or misuse, no liability shall be assumed nor accepted for any resulting damage or injury. By the act of use, setup or assembly, the user accepts all resulting liability. If you as the purchaser or user are not prepared to accept the liability associated with the use of the Product, purchaser is advised to return the Product immediately in new and unused condition to the place of purchase.

### Law

These terms are governed by Illinois law (without regard to conflict of law principals). This warranty gives you specific legal rights, and you may also have other rights which vary from state to state. Horizon reserves the right to change or modify this warranty at any time without notice.

## WARRANTY SERVICES

### Questions, Assistance, and Services

Your local hobby store and/or place of purchase cannot provide warranty support or service. Once assembly, setup or use of the Product has been started, you must contact your local distributor or Horizon directly. This will enable Horizon to better answer your questions and service you in the event that you may need any assistance. For questions or assistance, please visit our website at [www.horizonhobby.com](http://www.horizonhobby.com), submit a Product Support Inquiry, or call the toll free telephone number referenced in the Warranty and Service Contact Information section to speak with a Product Support representative.

### Inspection or Services

If this Product needs to be inspected or serviced and is compliant in the country you live and use the Product in, please use the Horizon Online Service Request submission process found on our website or call Horizon to obtain a Return Merchandise Authorization (RMA) number. Pack the Product securely using a shipping carton. Please note that original boxes may be included, but are not designed to withstand the rigors of shipping without additional

protection. Ship via a carrier that provides tracking and insurance for lost or damaged parcels, as Horizon is not responsible for merchandise until it arrives and is accepted at our facility. An Online Service Request is available at [http://www.horizonhobby.com/content/\\_service-center\\_render-service-center](http://www.horizonhobby.com/content/_service-center_render-service-center). If you do not have internet access, please contact Horizon Product Support to obtain a RMA number along with instructions for submitting your product for service. When calling Horizon, you will be asked to provide your complete name, street address, email address and phone number where you can be reached during business hours. When sending product into Horizon, please include your RMA number, a list of the included items, and a brief summary of the problem. A copy of your original sales receipt must be included for warranty consideration. Be sure your name, address, and RMA number are clearly written on the outside of the shipping carton.

**NOTICE: Do not ship LiPo batteries to Horizon. If you have any issue with a LiPo battery, please contact the appropriate Horizon Product Support office.**

### Warranty Requirements

**For Warranty consideration, you must include your original sales receipt verifying the proof-of-purchase date.** Provided warranty conditions have been met, your Product will be serviced or replaced free of charge. Service or replacement decisions are at the sole discretion of Horizon.

### Non-Warranty Service

**Should your service not be covered by warranty, service will be completed and payment will be required without notification or estimate of the expense unless the expense exceeds 50% of the retail purchase cost.** By submitting the item for service you are agreeing to payment of the service without notification. Service estimates are available upon request. You must include this request with your item submitted for service. Non-warranty service estimates will be billed a minimum of ½ hour of labor. In addition you will be billed for return freight. Horizon accepts money orders and cashier's checks, as well as Visa, MasterCard, American Express, and Discover cards. By submitting any item to Horizon for service, you are agreeing to Horizon's Terms and Conditions found on our website [http://www.horizonhobby.com/content/\\_service-center\\_render-service-center](http://www.horizonhobby.com/content/_service-center_render-service-center).

**ATTENTION: Horizon service is limited to Product compliant in the country of use and ownership. If received, a non-compliant Product will not be serviced. Further, the sender will be responsible for arranging return shipment of the un-serviced Product, through a carrier of the sender's choice and at the sender's expense. Horizon will hold non-compliant Product for a period of 60 days from notification, after which it will be discarded.**



## Contact Information

| Country of Purchase      | Horizon Hobby   | Phone Number/Email Address  | Address  |
|--------------------------|---|---|--|
| United States of America | Horizon Service Center<br>(Repairs and Repair Requests)   | servicecenter.horizonhobby.com/<br>RequestForm/                   | 4105 Fieldstone Rd<br>Champaign, Illinois, 61822 USA                           |
|                          | Horizon Product Support<br>(Product Technical Assistance) | www.quickbase.com/db/<br>bghj7ey8c?a=GenNewRecord<br>888-959-2305 |  |
|                          | Sales   | sales@horizonhobby.com<br>888-959-2305                            |  |
| United Kingdom           | Service/Parts/Sales:<br>Horizon Hobby Limited             | sales@horizonhobby.co.uk<br>+44 (0) 1279 641 097                  | Units 1–4 , Ployters Rd, Staple Tye<br>Harlow, Essex, CM18 7NS, United Kingdom |
| Germany                  | Horizon Technischer Service<br>Sales: Horizon Hobby GmbH  | service@horizonhobby.de<br>+49 (0) 4121 2655 100                  | Christian-Junge-Straße 1<br>25337 Elmshorn, Germany                            |
| France                   | Service/Parts/Sales:<br>Horizon Hobby SAS                 | infofrance@horizonhobby.com<br>+33 (0) 1 60 18 34 90              | 11 Rue Georges Charpak<br>77127 Lieusaint, France                              |
| China                    | Service/Parts/Sales:<br>Horizon Hobby – China             | info@horizonhobby.com.cn<br>+86 (021) 5180 9868                   | Room 506, No. 97 Changshou Rd.<br>Shanghai, China 200060                       |



## FCC Information

Operation is subject to the following two conditions: (1) This device may not cause harmful interference, and (2) this device must accept any interference received, including interference that may cause undesired operation.

**CAUTION:** Changes or modifications not expressly approved by the party responsible for compliance could void the user's authority to operate the equipment.

This product contains a radio transmitter with wireless technology which has been tested and found to be compliant with the applicable regulations governing a radio transmitter in the 2.400GHz to 2.4835GHz frequency range.

## IC Information

This device complies with Industry Canada licence-exempt RSS standard(s). Operation is subject to the following two conditions: (1) this device may not

cause interference, and (2) this device must accept any interference, including interference that may cause undesired operation of the device.

## Compliance Information for the European Union



**EFL Brave Night Flyer BNF Basic (EFL6850)**

**EU Compliance Statement:** Horizon Hobby, LLC hereby declares that this product is in compliance with the essential requirements and other relevant provisions of the R&TTE and EMC Directive.

A copy of the EU Declaration of Conformity is available online at: <http://www.horizonhobby.com/content/support-render-compliance>.

## Instructions for disposal of WEEE by users in the European Union



This product must not be disposed of with other waste. Instead, it is the user's responsibility to dispose of their waste equipment by handing it over to a designated collections point for the recycling of waste electrical and electronic equipment. The separate collection and recycling of your waste equipment at the time of disposal will help to conserve natural resources and ensure that it is recycled in a manner that protects human health and the environment. For more information about where you can drop off your waste equipment for recycling, please contact your local city office, your household waste disposal service or where you purchased the product.

## Replacement Parts • Ersatzteile • Pièces de rechange • Pezzi di ricambio

| Part #   Nummer<br>Numéro   Codice | Description                     | Beschreibung  | Description                                  | Descrizione                     |
|------------------------------------|---------------------------------|---|--|---------------------------------|
| EFL6901                            | Fuselage w/lights: Brave        | E-flite Brave: Rumpf mit Beleuchtung                  | Brave - Fuselage avec éclairage              | Fusoliera con luci: Brave       |
| EFL6902                            | Wing set w/lights: Brave        | E-flite Brave: Tragflächenset mit Beleuchtung         | Brave - Ailes avec éclairage                 | Set ala con luci: Brave         |
| EFL6903                            | Tail setw/lights: Brave         | E-flite Brave: Leitwerkset mit Beleuchtung            | Brave - Empennage avec éclairage             | Set coda con luci: Brave        |
| EFL6904                            | Battery Hatch: Brave            | E-flite Brave: Akkuklappe                             | Brave - Trappe à batterie                    | Portello batteria: Brave        |
| EFL6905                            | Cowl w/screws: Brave            | E-flite Brave: Motorhaube mit Schrauben               | Brave - Capot avec vis                       | Naca motore con viti: Brave     |
| EFL6906                            | Spinner and Prop adapter: Brave | E-flite Brave: Spinner und Propelleradapter           | Brave - Cone et adaptateur d'hélices         | Ogiva e adattatore elica: Brave |
| EFL6907                            | Landing gear set: Brave         | E-flite Brave: Fahrwerkset                            | Brave - Train d'atterrissage                 | Set carrello: Brave             |
| EFL6908                            | Pushrod Set: Brave              | E-flite Brave: Gestängeset Brave                      | Brave - Set de tringlerie                    | Set aste comandi: Brave         |
| EFL6909                            | Hardware set: Brave             | E-flite Brave: Kleinteile (Schrauben und Ruderhörner) | Brave - Visserie et accessoires              | Set viteria: Brave              |
| EFL6910                            | Decal Sheet: Brave              | E-flite Brave: Dekorbogen                             | Brave - Planche de décoration                | Foglio adesivi: Brave           |
| EFLM1600                           | BL15 750kV outrunner            | E-flite BL15 Aussenläufer Motor, 750 kv               | Moteur Brushless BL15 750kV à cage tournante | Motore BL15 750kV outrunner     |
| EFLA1031                           | 30A Brushless ESC               | E-flite 30A Brushless ESC                             | Contrôleur Brushless 30A                     | ESC 30A Brushless               |
| SPMSA330                           | 9 gram servo                    | Spektrum 9g Servo                                     | Servo 9g                                     | Servo da 9 grammi               |
| EFLA415                            | LED light controller: Brave     | E-flite Brave: LED Controller mit Kabelbaum           | Brave - Module commande d'éclairage          | Centralina luci a LED: Brave    |
| EFLP10803B                         | 10 x 8 three blade prop: Brave  | E-flite Brave: 10 x 8 3-Blattpropeller                | Brave - Hélice tripale 10 x 8                | Elica tripala 10x8: Brave       |

## Optional Parts • Optionale Bauteile • Pièces optionnelles • Pezzi opzionali

| Part #   Nummer<br>Numéro   Codice | Description                                  | Beschreibung   | Description                                       | Descrizione                                     |
|------------------------------------|--|--|---|---|
| EFLA250                            | Park Flyer Tool Assortment, 5 pc             | Park Flyer Werkzeugsortiment, 5 teilig                   | Assortiment d'outils park flyer, 5pc              | Park Flyer assortimento attrezzi, 5 pc          |
| EFLAEC302                          | EC3 Battery Connector, Female (2)            | EC3 Akkukabel, Buchse (2)                                | Prise EC3 femelle (2pc)                           | EC3 Connettore femmina x batteria (2)           |
| EFLAEC303                          | EC3 Device/Battery Connector, Male/Female    | EC3 Kabelsatz, Stecker/Buchse                            | Prise EC3 male/femelle                            | EC3 Connettore batteria maschio/femmina         |
| EFLB22003S50                       | 11.1V 3S 30C 3200MAH Li-Po                   | 11.1V 3S 30C 3200mAh LiPo                                | 11.1V 3S 30C 3200MAH Li-Po                        | 11.1V 3S 30C 3200MAH Li-Po                      |
| DYNC2020A                          | Prophet Sport Duo 50W x 2 AC Battery Charger | Dynamite Prophet Sport Duo 50W x 2 AC Ladegerät, EU      | Chargeur Prophet Sport Duo 50W x 2 AC             | Carica batterie Prophet Sport Duo 50W x 2 AC    |
| DYNC2010CA                         | Prophet Sport Plus 50W AC DC Charger         | Dynamite Ladegerät Prophet Sport Plus 50W AC/DC EU       | Chargeur Prophet Sport Plus 50W AC DC             | Caricabatterie Prophet Sport Plus 50W AC DC     |
| SPMA380                            | AS3X Programming Cable - Audio Interface     | Spektrum Audio-Interface AS3X Empfänger Programmierkabel | Câble de programmation audio AS3X pour smartphone | Cavo di programmazione AS3X - Interfaccia audio |
| SPMA3065                           | AS3X Programming Cable - USB Interface       | Spektrum USB-Interface AS3X Empfänger Programmierkabel   | Câble de programmation USB AS3X pour PC           | Cavo di programmazione AS3X - Interfaccia USB   |
| EFLA111                            | Li-Po Cell Voltage Checker                   | Li-Po Cell Voltage Checker                               | Testeur de tension d'éléments Li-Po               | Voltmetro verifica batterie LiPo                |
| DYN1405                            | Li-Po Charge Protection Bag, Large           | Dynamite LiPoCharge Protection Bag groß                  | Sac de charge Li-Po, grand modèle.                | Sacchetto grande di protezione per carica LiPo  |
| DYN1400                            | Li-Po Charge Protection Bag, Small           | Dynamite LiPoCharge Protection Bag klein                 | Sac de charge Li-Po, petit modèle                 | Sacchetto piccolo di protezione per carica LiPo |
|                                    | DX6i DSMX 6-Channel Transmitter              | Spektrum DX6i DSMX 6-Kanal Sender                        | Emetteur DX6i DSMX 6 voies                        | DX6i DSMX Trasmettitore 6 canali                |
|                                    | DX6 DSMX 6-Channel Transmitter               | Spektrum DX6 DSMX 6-Kanal Sender                         | Emetteur DX6 DSMX 6 voies                         | DX6 DSMX Trasmettitore 6 canali                 |
|                                    | DX7 DSMX 7-Channel Transmitter               | Spektrum DX7 DSMX 7 Kanal Sender                         | Emetteur DX7 DSMX 7 voies                         | DX7 DSMX Trasmettitore 7 canali                 |
|                                    | DX9 DSMX 9-Channel Transmitter               | Spektrum DX9 DSMX 9 Kanal Sender                         | Emetteur DX9 DSMX 9 voies                         | DX9 DSMX Trasmettitore 9 canali                 |
|                                    | DX18 DSMX 18-Channel Transmitter             | Spektrum DX18 DSMX 18 Kanal Sender                       | Emetteur DX18 DSMX 18 voies                       | DX18 DSMX Trasmettitore 18 canali               |



# Pawnee Brave Night Flyer

© 2015 Horizon Hobby, LLC.

E-flite, AS3X, DSM, DSM2, DSMX, the DSMX logo, Bind-N-Fly, Z-Foam, ModelMatch, EC3, Celectra, Prophet and the Horizon Hobby logo are trademarks or registered trademarks of Horizon Hobby, LLC.

The Spektrum trademark is used with permission of Bachmann Industries, Inc.

Futaba is a registered trademark of Futaba Denshi Kogyo Kabushiki Kaisha Corporation of Japan.

All other trademarks, service marks and logos are property of their respective owners.

Patents pending.

<http://www.e-fliterc.com/>