

Name: _____		Date: _____		Event: _____	
City: _____		State: _____		Track: _____	
Track Conditions: <input type="checkbox"/> Indoor <input type="checkbox"/> Tight <input type="checkbox"/> Smooth <input type="checkbox"/> Hard Packed <input type="checkbox"/> Blue Groove <input type="checkbox"/> Wet <input type="checkbox"/> Low Bite <input type="checkbox"/> High Bite <input type="checkbox"/> Outdoor <input type="checkbox"/> Open <input type="checkbox"/> Rough <input type="checkbox"/> Loose/Loamy <input type="checkbox"/> Dry <input type="checkbox"/> Dusty <input type="checkbox"/> Med Bite <input type="checkbox"/> Other _____					

**Front Suspension**

Toe: \_\_\_\_\_

Ride Height: \_\_\_\_\_

Camber: \_\_\_\_\_

Caster: \_\_\_\_\_

Spindle Height:  High  Low

Wheel Hex: \_\_\_\_\_

Sway Bar: \_\_\_\_\_

Piston/Oil: \_\_\_\_\_

Shock Type:  Bladder  Emulsion

Spring: \_\_\_\_\_

Limiter/Droop: \_\_\_\_\_

Overall Shock Length: \_\_\_\_\_

Steering Ackerman: \_\_\_\_\_

Bump Steer: \_\_\_\_\_

Camber Link: \_\_\_\_\_

Shock Location: \_\_\_\_\_

Receiver Battery Type: \_\_\_\_\_

**Differentials**

Front:  Standard  Smart

Spring Wire Dia.: \_\_\_\_\_

Qty of Springs: \_\_\_\_\_

Ramp Plate: \_\_\_\_\_

Grease: \_\_\_\_\_

Diff Fluid: \_\_\_\_\_

Center:  Standard  Smart

Spring Wire Dia.: \_\_\_\_\_

Qty of Springs: \_\_\_\_\_

Ramp Plate: \_\_\_\_\_

Grease: \_\_\_\_\_

Diff Fluid: \_\_\_\_\_

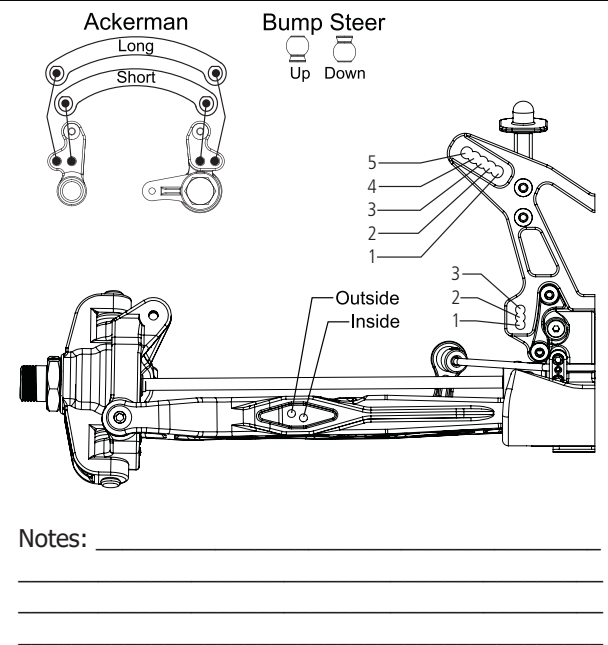

**Rear Suspension**

Roll Center:  HRC  LRC

Toe: \_\_\_\_\_

Anti-Squat: \_\_\_\_\_

Ride Height: \_\_\_\_\_

Camber: \_\_\_\_\_

Rear Hub Spacing: \_\_\_\_\_

Wheel Hex: \_\_\_\_\_

Sway Bar: \_\_\_\_\_

Piston/Oil: \_\_\_\_\_

Shock Type:  Bladder  Emulsion

Spring: \_\_\_\_\_

Limiter/Droop: \_\_\_\_\_

Overall Shock Length: \_\_\_\_\_

Camber Link: \_\_\_\_\_

Shock Position: \_\_\_\_\_

Rear Diff Fluid: \_\_\_\_\_

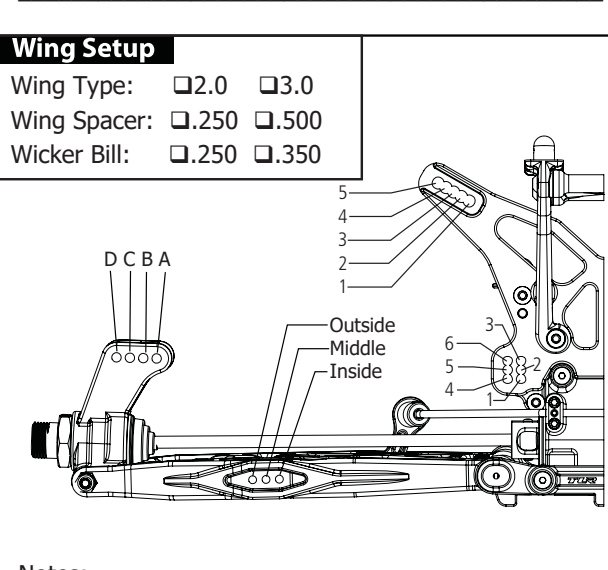

**Engine**

Engine: \_\_\_\_\_ Fuel: \_\_\_\_\_

Glow Plug: \_\_\_\_\_ Head Clearance \_\_\_\_\_

Pipe/Header: \_\_\_\_\_ Gearing: \_\_\_\_\_

**Clutch**

Clutch Shoes and Springs Info

\_\_\_\_\_

\_\_\_\_\_

\_\_\_\_\_

**Tires**

Type	Compound	Insert
Front: _____	_____	_____
Rear: _____	_____	_____
Notes: _____		