

RTR
READY-TO-RUN

EIGHT-E™

1/8-SCALE HIGH-PERFORMANCE 4WD ELECTRIC BUGGY

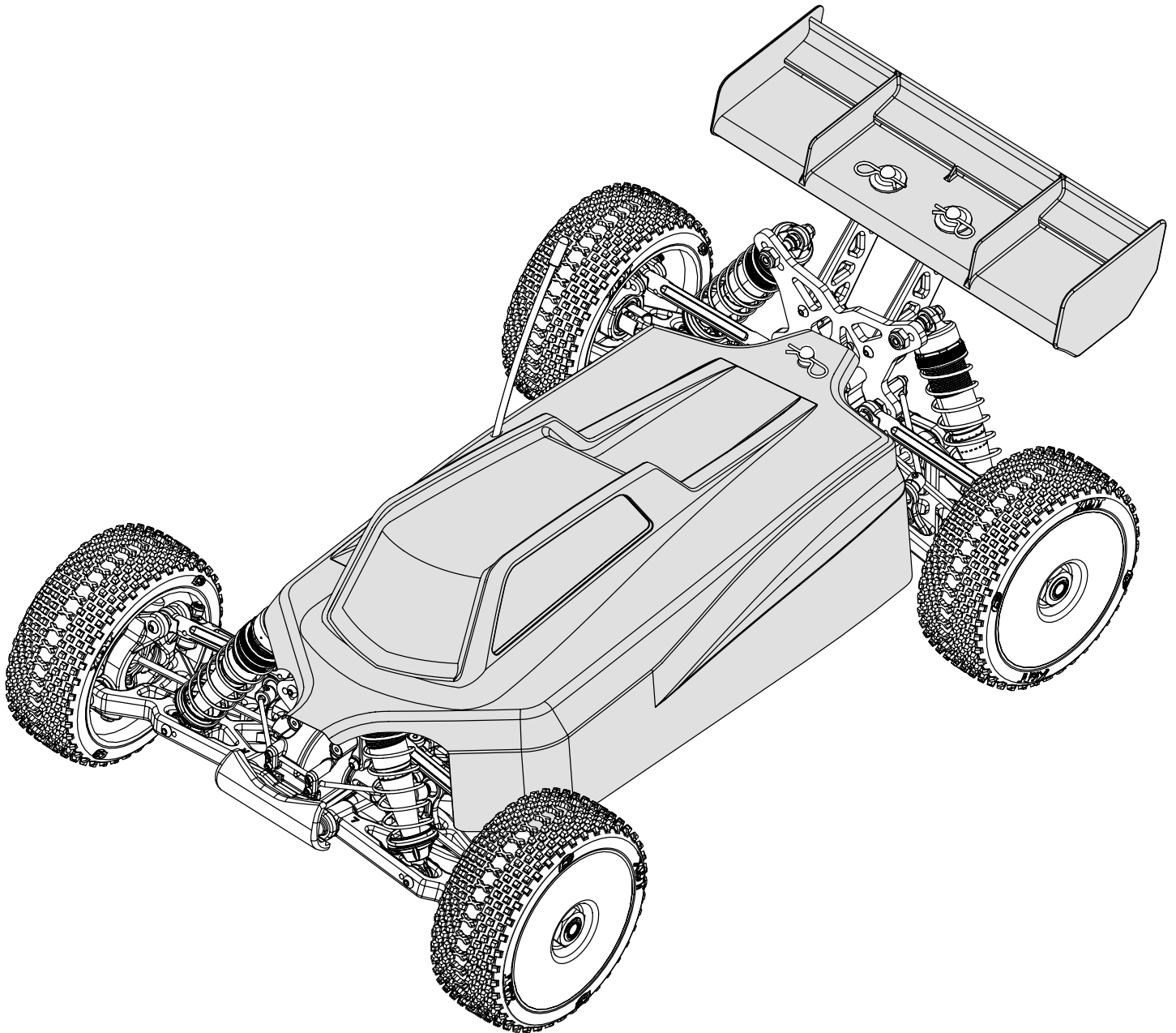

INSTRUCTION MANUAL
BEDIENUNGSANLEITUNG
MANUEL D'UTILISATION
MANUALE DI ISTRUZIONI



Before operating this vehicle, please read all printed materials thoroughly.
Horizon Hobby is not responsible for inadvertent errors in this manual.

NOTICE

All instructions, warranties and other collateral documents are subject to change at the sole discretion of Horizon Hobby, LLC. For up-to-date product literature, visit horizonhobby.com and click on the support tab for this product.

MEANING OF SPECIAL LANGUAGE

The following terms are used throughout the product literature to indicate various levels of potential harm when operating this product:

WARNING: Procedures, which if not properly followed, create the probability of property damage, collateral damage, and serious injury OR create a high probability of superficial injury.

CAUTION: Procedures, which if not properly followed, create the probability of physical property damage AND a possibility of serious injury.

NOTICE: Procedures, which if not properly followed, create a possibility of physical property damage AND a little or no possibility of injury.

 **WARNING:** Read the ENTIRE instruction manual to become familiar with the features of the product before operating. Failure to operate the product correctly can result in damage to the product, personal property and cause serious injury.

This is a sophisticated hobby product. It must be operated with caution and common sense and requires some basic mechanical ability. Failure to operate this Product in a safe and responsible manner could result in injury or damage to the product or other property. This product is not intended for use by children without direct adult supervision. Do not use with incompatible components or alter this product in any way outside of the instructions provided by Horizon Hobby, LLC. This manual contains instructions for

safety, operation and maintenance. It is essential to read and follow all the instructions and warnings in the manual, prior to assembly, setup or use, in order to operate correctly and avoid damage or serious injury.

WARNING AGAINST COUNTERFEIT PRODUCTS

Always purchase from a Horizon Hobby authorized dealer to ensure authentic high-quality Spektrum product. Horizon Hobby, LLC disclaims all support and warranty with regards, but not limited to, compatibility and performance of counterfeit products or products claiming compatibility with DSM or Spektrum technology.

Age Recommendation: Not for children under 14 years. This is not a toy.

SAFETY PRECAUTIONS AND WARNINGS

- Always keep a safe distance in all directions around your model to avoid collisions or injury. This model is controlled by a radio signal subject to interference from many sources outside your control. Interference can cause momentary loss of control.
- Always operate your model in open spaces away from full-size vehicles, traffic and people.
- Always carefully follow the directions and warnings for this and any optional support equipment (chargers, rechargeable battery packs, etc.).
- Always keep all chemicals, small parts and anything electrical out of the reach of children.
- Always avoid water exposure to all equipment not specifically designed and protected for this purpose. Moisture causes damage to electronics.
- Never place any portion of the model in your mouth as it could cause serious injury or even death.
- Never operate your model with low transmitter batteries.

TABLE OF CONTENTS

Register Your Losi Product Online	2
Components	
Tools Needed	
Tools Included	
Needed to Complete	
Contents	3
Water-Resistant Vehicle with Waterproof Electronics	3
Quick Start	3
Spektrum DX2E Radio System	4
Installing the Transmitter Batteries	
Binding and Calibrating the Receiver	4
Batteries and Charging	4
Control Test	5
Before Running Your Vehicle	5
Driving Precautions	5
Run Time	5
Powering ON the Vehicle	5
Operation	5
Dynamite Fuze 130A Sensorless Brushless ESC	6
Tuning, Adjusting & Maintaining Your Vehicle	8
Changing the Travel Adjust Settings	8
Service/Repair	8
Troubleshooting Guide	8
Limited Warranty	9
FCC Information	10
IC Information	10
EU Compliance Statement	10
Parts Listings	35–39
Exploded View	40–43

REGISTER YOUR LOSI PRODUCT ONLINE

Register your vehicle now and be the first to find out about the latest option parts, product updates and more. Click on the Support tab at WWW.LOSI.COM and follow the product registration link to stay connected.

COMPONENTS

- Losi® 8IGHT-ETM RTR: 1/8-Scale 4WD Buggy (LOS04014)
- Spektrum™ DX2E 2.4GHz Transmitter (SPM2330)
- SPMSR310 3-Channel DSMR® Surface Receiver (SPMSR310)
- Fuze™ 130A Brushless Waterproof ESC (DYN4955)
- Fuze 1/8 Scale 2500KV Brushless Sensorless Motor (DYN51805)
- 9KG Servo, Waterproof, 23T (SPMS605)
- 4 AA batteries (for transmitter)

TOOLS NEEDED

- Small flat blade and Phillips screwdrivers
- Needle-nose pliers
- Quality .050-inch, 1/16-inch, 5/64-inch, 3/32-inch, 1.5mm and 2.5mm hex (Allen) drivers

TOOLS INCLUDED

- Wheel Wrench
- Four (4) Hex "L" Wrench Set: .050-inch, 1/16-inch, 5/64-inch, and 3/32-inch
- Shock Bottom wrench
- Turnbuckle/Shock Top wrench

NEEDED TO COMPLETE

- Battery: Dynamite® Reaction® 15.2V 5000mAh 4S 50C Li-Po: EC5™ connector (DYNB3854EC)
- Charger: Dynamite® Prophet™ Precept™ 80W LCD AC/DC (DYN2015)

Use only Dynamite® tools or other high-quality tools. Use of inexpensive tools can cause damage to the small screws and parts used on this type of model.

CONTENTS

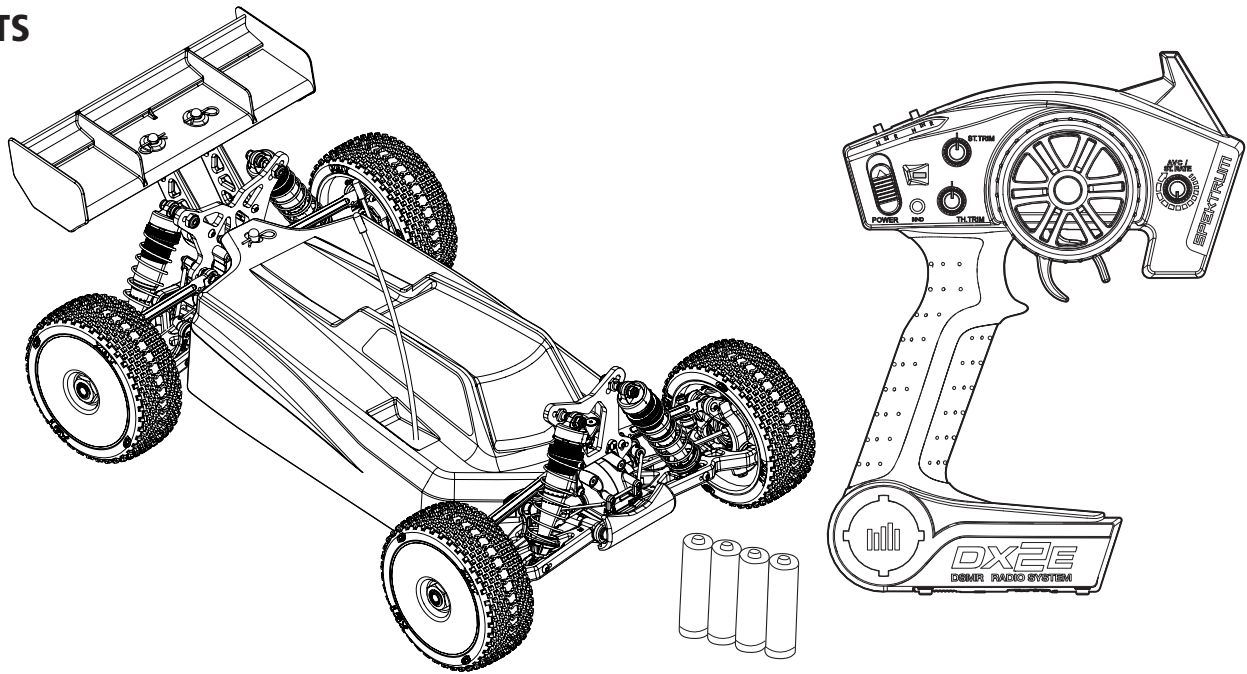

WATER-RESISTANT VEHICLE WITH WATERPROOF ELECTRONICS

Your new Horizon Hobby vehicle has been designed and built with a combination of waterproof and water-resistant components to allow you to operate the product in many “wet conditions,” including puddles, creeks, wet grass, snow and even rain.

While the entire vehicle is highly water-resistant, it is not completely waterproof and your vehicle should NOT be treated like a submarine. The various electronic components used in the vehicle, such as the Electronic Speed Control (ESC), servo(s) and receiver are waterproof, however, most of the mechanical components are water-resistant and should not be submerged.

Metal parts, including the bearings, hinge pins, screws and nuts, as well as the contacts in the electrical cables, will be susceptible to corrosion if additional maintenance is not performed after running in wet conditions. To maximize the long-term performance of your vehicle and to keep the warranty intact, the procedures described in the “Wet Conditions Maintenance” section below must be performed regularly if you choose to run in wet conditions. If you are not willing to perform the additional care and maintenance required, then you should not operate the vehicle in those conditions.

⚠ CAUTION: Failure to exercise caution while using this product and complying with the following precautions could result in product malfunction and/or void the warranty.

GENERAL PRECAUTIONS

- Read through the wet conditions maintenance procedures and make sure that you have all the tools you will need to properly maintain your vehicle.
- Not all batteries can be used in wet conditions. Consult the battery manufacturer before use. Caution should be taken when using Li-Po batteries in wet conditions.
- Most transmitters are not water-resistant. Consult your transmitter’s manual or the manufacturer before operation.
- Never operate your transmitter or vehicle where lightning may be present.
- Do not operate your vehicle where it could come in contact with salt water (ocean water or water on salt-covered roads), contaminated or polluted water. Salt water is very conductive and highly corrosive, so use caution.
- Even minimal water contact can reduce the life of your motor if it has not been certified as water-resistant or waterproof. If the motor becomes excessively wet, apply very light throttle until the water is mostly removed from the motor. Running a wet motor at high speeds may rapidly damage the motor.

QUICK START

Please read the entire manual to gain a full understanding of the 8IGHT-E™ RTR buggy, fine-tuning the setup and performing maintenance.

1. Read the safety precautions found in this manual.
2. Charge the battery pack you have chosen (NOT INCLUDED). Refer to the Manufacturer’s Supplied instructions for battery charging information.
3. Install the AA batteries in the transmitter. Only use alkaline or rechargeable batteries.
4. Install a fully charged battery in the vehicle.
5. Power ON the transmitter and then the vehicle. Always power the transmitter ON before the vehicle and power it OFF after the vehicle has been powered OFF.
6. Check the steering and throttle control directions. Verify that the servo is moving in the correct direction.
7. Drive your vehicle.
8. Perform any necessary maintenance.

- Driving in wet conditions can reduce the life of the motor. The additional resistance of operating in water causes excess strain. Alter the gear ratio by using a smaller pinion or larger spur gear. This will increase torque (and motor life) when running in mud, deeper puddles, or any wet conditions that will increase the load on the motor for an extended period of time.

WET CONDITIONS MAINTENANCE

- Drain any water that has collected in the tires by spinning them at high speed. With the body removed, place the vehicle upside down and pull full throttle for a few short bursts until the water has been removed.

⚠ CAUTION: Always keep hands, fingers, tools and any loose or hanging objects away from rotating parts when performing the above drying technique.

- Remove the battery pack(s) and dry the contacts. If you have an air compressor or a can of compressed air, blow out any water that may be inside the recessed connector housing.
- Remove the tires/wheels from the vehicle and gently rinse the mud and dirt off with a garden hose. Avoid rinsing the bearings and transmission.

NOTICE: Never use a pressure washer to clean your vehicle.

- Use an air compressor or a can of compressed air to dry the vehicle and help remove any water that may have gotten into small crevices or corners.
- Spray the bearings, drive train, fasteners and other metal parts with a water-displacing light oil. Do not spray the motor.
- Let the vehicle air dry before you store it. Water (and oil) may continue to drip for a few hours.
- Increase the frequency of disassembly, inspection and lubrication of the following:
 - Front and rear axle hub assembly bearings.
 - All transmission cases, gears and differentials.
 - Motor—clean with an aerosol motor cleaner and re-oil the bushings with lightweight motor oil.

SPEKTRUM DX2E RADIO SYSTEM

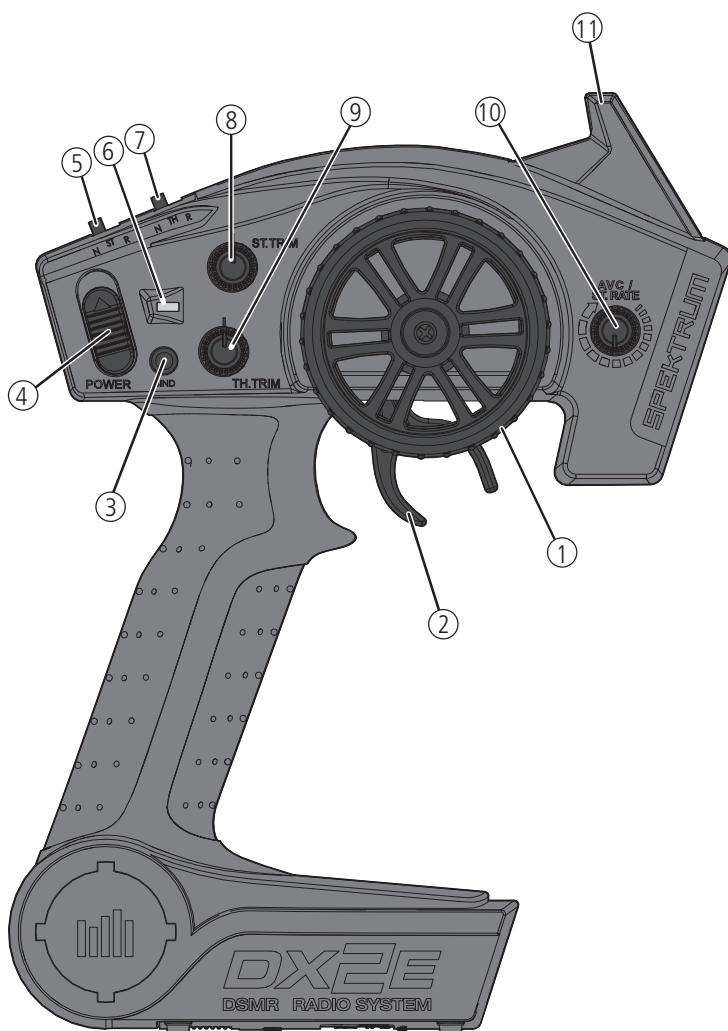

For more information on the transmitter, go to www.horizonhobby.com and click on the support tab for the Spektrum DX2E to download the instruction manual.

1. **Steering Wheel** Controls direction (left/right) of the model
2. **Throttle Trigger** Controls speed (forward/brake) of the model
3. **BIND Button** Puts the transmitter into Bind Mode
4. **ON/OFF Switch** Turns the power ON/OFF for the transmitter
5. **ST REV** Reverses the function of the steering when the wheel is turned left or right
6. **Indicator Lights**
 - Solid green light—indicates adequate battery power
 - Flashing green light—indicates the battery voltage is critically low. Replace batteries
7. **TH REV** Reverses the function of the speed control when pulled back or pushed forward
8. **ST Trim** Adjusts the steering center point
9. **TH Trim** Adjusts the throttle neutral point
10. **ST Rate** Adjusts the steering limits
11. **Antenna** Transmits the signal to the model

INSTALLING THE TRANSMITTER BATTERIES

This transmitter requires 4 AA batteries.

1. Remove the battery cover from the transmitter.
2. Install the batteries as shown.
3. Install the battery cover.

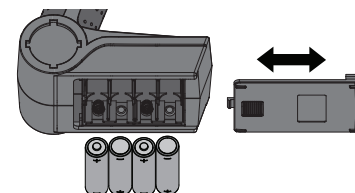

CAUTION: If using rechargeable batteries, charge only rechargeable batteries. Charging non-rechargeable batteries may cause the batteries to burst, resulting in injury to persons and/or damage to property.

CAUTION: Risk of explosion if battery is replaced by an incorrect type. Dispose of used batteries according to national regulations.

BINDING AND CALIBRATING THE RECEIVER

The included transmitter and receiver are bound at the factory. To rebind:

1. Power off the transmitter and receiver.
2. Insert the bind plug into the BIND port on the receiver.
3. Power on the receiver. The LED in the receiver flashes rapidly, indicating that the receiver is in bind mode.
4. With the throttle in neutral, power on the transmitter while pressing the bind button. The LED in the receiver turns solid when binding is complete.
5. Remove the bind plug from the receiver after binding is complete.

You must rebind when binding the receiver to a different transmitter.

NOTICE: Do not attempt to bind the transmitter and receiver if there are other compatible transmitters in bind mode within 400 feet. Doing so may result in unexpected binding.

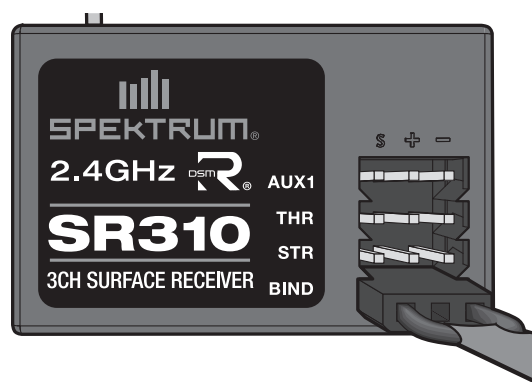

BATTERIES AND CHARGING

Your vehicle uses rechargeable Li-Po batteries. These batteries all have special requirements to preserve performance.

- Read all instructions provided by the manufacturer of the batteries.
- Never allow minors to charge battery packs.
- Always check to ensure the polarity of the battery connection is correct.
- Never leave batteries unattended while charging.

- Never charge a battery while it is installed in the vehicle.
- Do not charge any battery that appears to have any damage.
- If there are exposed wires, do not charge or use the battery until you install shrink-wrap or replace the complete wire.

When charging Li-Po batteries, select a charger to meet your requirements. You need a charger that is a 100–240V wall charger or one which requires a 12V power supply. Follow the charger manufacturer's instructions and precautions during each use.

CONTROL TEST

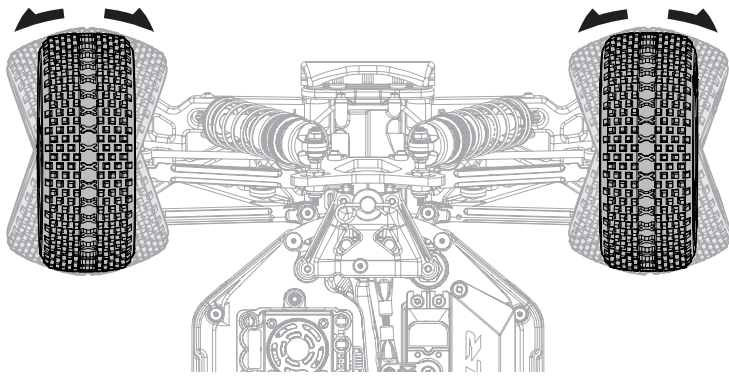

Perform a control test with the vehicle wheels off the ground. If the wheels rotate after the vehicle is powered ON, adjust the TH TRIM knob until they stop. To make the wheels move forward, pull the trigger. To reverse them, wait for the wheels to stop, then push the trigger. When moving forward, the wheels should maintain a straight line without any steering wheel input. If not, adjust the ST TRIM knob so the wheels maintain a straight line without having to turn the steering wheel.

BEFORE RUNNING YOUR VEHICLE

1. Break in the differentials. While holding the chassis with only the left side tires firmly on the ground, give the car about 1/8 throttle for 30 seconds. The right side tires should spin freely during this time. Repeat this with only the right side tires firmly on the ground, allowing the left side tires to spin freely. Repeat this 2–3 times.
2. Check for free suspension movement. All suspension arms and steering components should move freely. Any binds will cause the car to handle poorly.
3. Charge the battery.
4. Check the calibration of the ESC. If recalibration is required, refer to the **130A Sensorless Brushless ESC** section.
5. Adjust the transmitter settings to your desired configuration.

POWERING ON THE VEHICLE

1. Center the ST TRIM and TH TRIM dials on the transmitter.
2. Power on the transmitter.
3. Remove the body from the vehicle.
4. Connect a fully charged battery pack to the ESC.
5. Power on the ESC.

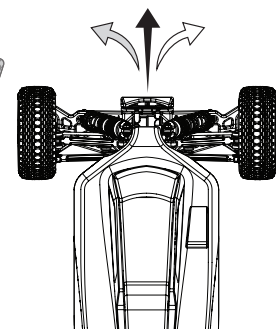
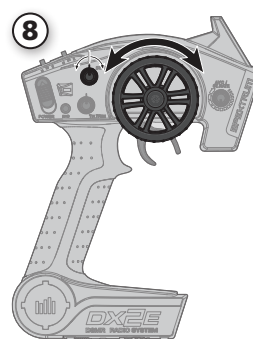
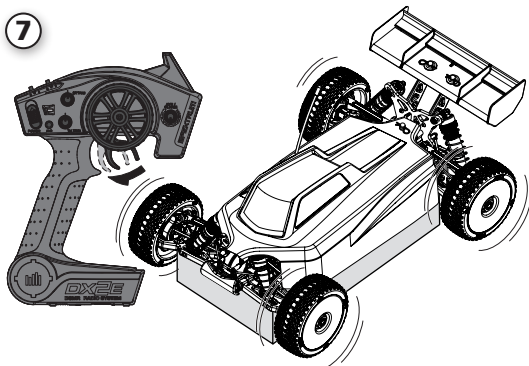
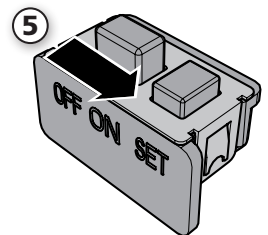
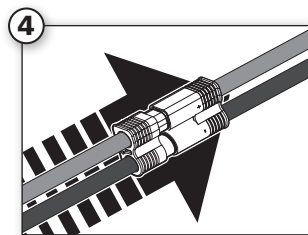
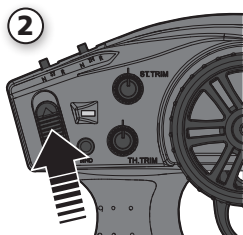
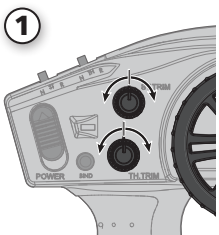

DRIVING PRECAUTIONS

- Maintain sight of the vehicle at all times.
- Inspect the vehicle for loose wheel hardware.
- Inspect the steering assembly for any loose hardware. Driving the vehicle off-road can cause fasteners to loosen over time.
- Do not drive the vehicle in tall grass. Doing so can damage the vehicle or electronics.
- Stop driving the vehicle when you notice a lack of power. Driving the vehicle when the battery is discharged can cause the receiver to power off. You may lose control of the vehicle.
- Do not apply the throttle in forward or reverse if the vehicle is stuck. Applying throttle in this instance can damage the motor or ESC.
- After driving the vehicle, allow the electronics to cool to ambient temperature before using the next battery pack.

RUN TIME

The largest factor in run time is the capacity of the battery pack. A larger mAh rating increases the amount of run time.

The condition of a battery pack is also an important factor in both run time and speed. The battery connectors may become hot during driving. Batteries will lose performance and capacity over time.

Driving the vehicle from a stop to full speed repeatedly will damage the batteries and electronics over time. Sudden acceleration will also lead to shorter run times.

TO IMPROVE RUN TIMES

- Keep your vehicle clean and well maintained.
- Allow more airflow to the ESC and motor.
- Change the gearing to a lower ratio. A lower ratio lowers the operating temperature of the electronics. Use a smaller pinion gear or larger spur gear to lower the gear ratio.
- Use a battery pack with a higher mAh rating.

6. Re-install the body on the vehicle.
7. Perform a test of the transmitter's control of the vehicle with the vehicle's wheels off the ground.
8. Start driving slowly. If the vehicle does not go straight, adjust the ST dial on the transmitter.

OPERATION

- **ALWAYS** turn on your transmitter before you turn on the receiver in the vehicle. Always power off the receiver before turning your transmitter off.
- **ALWAYS** operate your vehicle in a wide open area. Operating the vehicle in a small space or indoors can cause overheating at low speeds. Operating at low speed increases heat in the electronic speed control (ESC). Overheating can damage the vehicle and failure may result.

DYNAMITE® FUZE™ 130A SENSORLESS BRUSHLESS ESC

SPECIFICATIONS

Type	Sensorless
Constant/Peak	130A/760A
Resistance	0.0004 Ohm
Function	Forward/Brake—Forward/Brake Reverse
Operation	Proportional forward, proportional reverse with braking delay
Input Voltage	7.4V–14.8V
BEC Output	6V/3A
Overload Protection	Thermal
Dimensions (LxWxH)	53.5mm x 36mm x 36mm
Weight	79 g

ESC LED STATUS

- No ESC LEDs will glow when there is no throttle input from the transmitter.
- The red ESC LED glows when there is any throttle input from the transmitter.

AUDIBLE WARNING TONES

- 1. Input Voltage:** The ESC checks the input voltage when it is powered ON. If a voltage problem is detected, the ESC continuously sounds 2 beeps with a 1 second pause (xx-xx-xx). Power OFF the ESC and ensure the connections are secure and that the battery power is not too low for safe operation.
- 2. Radio Connection:** The ESC checks radio signal input when it is powered ON. If a problem is detected, the ESC continuously sounds 1 beep with a 2 second pause (x--x--x). Power OFF the ESC and ensure the radio system is operating correctly.

For sensorless brushless motors:

1. Connect the ESC terminal A (typically designated by a blue wire) to the motor's terminal A (red wire on a Dynamite® Fuze™ sensorless motor). This may also be changed in Programming Item 12, Motor Rotation, without changing wire connections.
2. Connect the ESC terminal B (typically designated by a yellow wire) to the motor's terminal B (blue wire on a Dynamite® Fuze™ sensorless motor).
3. Connect the ESC terminal C (typically designated by an orange wire) to the motor's terminal C (black wire on a Dynamite® Fuze™ sensorless motor).

NOTICE: Always disconnect the battery from the ESC when you have finished operating your vehicle. The ESC's switch only controls power to the receiver and servos. The ESC will continue to draw current when connected to the battery, resulting in possible damage to the battery through over discharge.

ESC CALIBRATION PROCEDURE

Ensure proper ESC function by calibrating the ESC to your transmitter inputs.

1. Power OFF the ESC.
2. Ensure your transmitter is powered ON, the throttle is not reversed, the throttle trim is neutral and the throttle travel range is at 100%. Disable any special functions such as ABS, etc.
3. Press the SET button while powering ON the ESC. Release the button as soon as the red LED starts to flash.
4. Calibrate the throttle points by pressing the SET button once after each step.
 - Neutral (1 flash)—leave the throttle at rest, untouched
 - Full throttle (2 flashes)—pull the throttle fully back
 - Full brake/reverse (3 flashes)—push the throttle fully forward

Tip: If the motor turns in the wrong direction, reverse the connection of any 2 outside motor wires. The center wire must remain in the center and cannot be moved to another motor tab.

ESC FUNCTIONS AND MODES

The ESC includes programming options so you can adjust the way your vehicle performs. Refer to the included settings table to adjust the ESC for your driving conditions.

ESC PROGRAMMING PROCEDURE

Programming is accomplished using the SET button on the ON/OFF switch or Digital Program Box (DYN3005).

1. Connect a fully charged battery to the ESC.
2. Power ON the ESC using the ESC switch.
3. Hold the SET button for 1 second until the green LED blinks, then release the SET button to enter programming mode.
4. Press and release the SET button as needed to get to the desired menu option (the Green LED will blink corresponding to the menu item number). Programming menu items 1 through 9 are accessible using the SET button on the ESC. Programming menu items 10 and above are only accessible using the optional ESC programming card. Programming of menu items 10 and 11 is only possible after firmware updates to the ESC programming card.
5. When at the desired menu item, hold the SET button for 3 seconds until the red LED blinks.
6. Press the SET button to move among the settings based on how many times the red LED blinks (Refer to the table for more information).
7. Save the setting by holding the SET button for 3 seconds.
8. Power OFF the ESC switch and repeat the instructions above to change other settings.

Tip: If desired, the ESC programming can be returned to default settings by powering ON the ESC and holding the SET button for 5 seconds.

PROGRAMMABLE ITEMS	PROGRAMMABLE VALUE								
	1	2	3	4	5	6	7	8	9
1 Running Mode	Forward with Brake	Forward/Reverse with Brake	Forward/Reverse						
2 Drag Brake Force	0%	5%	10%	20%	40%	60%	80%	100%	
3 Low Voltage Cutoff	non-protection	2.6 V/Cell	2.8 V/Cell	3.0 V/Cell	3.2 V/Cell	3.4 V/Cell			
4 Start Mode	Level 1	Level 2	Level 3	Level 4	Level 5	Level 6	Level 7	Level 8	Level 9
5 Max Brake Force	25%	50%	75%	100%	disable				
6 Max Reverse Force	25%	50%	75%	100%					
7 Initial Brake Force	= Drag Brake Force	0%	20%	40%					
8 Neutral Range	6% (Narrow)	9% (Normal)	12% (Wide)						
9 Timing	0.00°	3.75°	7.50°	11.25°	15.00°	18.75°	22.50°	26.25°	
10 Reserved Item									
11 Reserved Item									
12 Motor Rotation	Counter-clockwise	Clockwise							
13 Li-Po Cells	Auto Calculate	2 Cells	3 Cells	4 Cells	5 Cells	6 Cells			

DESCRIPTIONS

1. Running Mode

- *Forward Only with Brake*
Intended for competition use, this mode allows only forward and brake controls.

- *Forward/Reverse with Brake*
This mode is the basic all-around mode, allowing forward, reverse and brake controls. To engage reverse while moving forward, apply the brake until the vehicle has come to a complete stop, release brake, then apply the brake again. While braking or in reverse, engaging the throttle will result in the vehicle immediately accelerating forward.

2. Drag Brake Force

Adjusts the amount of brake automatically applied when the throttle is returned to the neutral position. This simulates the engine braking effect of a full-scale vehicle, allowing improved turn-in and your vehicle's general response to controls.

3. Low Voltage Cutoff

This function helps to prevent battery over-discharge. The ESC continuously monitors the battery's voltage. If the voltage falls below the voltage threshold for 2 seconds, the output power shuts off and the red LED flashes twice repeatedly.

The cutoff threshold calculation is based on individual Li-Po cell voltage. For Ni-MH batteries, if the voltage battery pack is higher than 9.0V, it will be treated as a 3-cell Li-Po battery pack; if it is lower than 9.0V, it will be treated as a 2-cell Li-Po battery pack. Example: for a 8.0V Ni-MH battery pack used with a 2.6V/cell threshold, it will be treated as a 2-cell Li-Po battery pack and the low-voltage cut-off threshold will be 5.2V (2.6x2=5.2). Using the optional Digital Program Box (DYN3005), you can adjust the custom values for the cutoff threshold. Unlike the preset values, custom cutoff values are for the total battery voltage, not individual cell voltage.

4. Start Mode (Punch)

Sets the initial throttle punch when the car accelerates. Level 1 gives a very soft initial acceleration and level 9 gives a very strong initial acceleration. When using levels 7, 8 or 9, you must use high-power batteries. With low power batteries, the battery could overload and result in poor performance or unexpected results.

5. Max Brake Force

Adjusts the maximum braking force. A higher value provides stronger braking, but can also cause the wheels to lock, resulting in loss of control of the car.

6. Max Reverse Force

This parameter adjusts the maximum power when travelling in reverse.

7. Initial Brake Force (minimum brake)

Adjusts the minimum amount of braking power when the brakes engage. The default value is equal to the drag brake value. A high value can lock the wheels when the brake is used.

8. Neutral Range

Adjusts the throttle sensitivity around the neutral point. A higher value results in the throttle having to be moved more for the vehicle to move forward, backward or brake.

9. Timing

Adjusts the motor drive current timing. More timing gives more performance, but can lower efficiency and cause damage to the motor and/or ESC by overload or overheating.

NOTICE: Always ensure the motor timing is set correctly. Failure to set the motor timing correctly can result in damage to the motor and ESC. Refer to the manufacturer instructions for recommended timing settings.

The Following Programmable Items require the optional Digital ESC Program Box: (DYN3005): 10 and 11.

Available Items are subject to firmware updates to the ESC and the optional digital program box.

12. Motor Rotation

Lets you make this change in the ESC so no wires need to be changed between the ESC and the motor.

13. Li-Po Cells

Allows the ESC to automatically detect or manually set the number of cells in your Li-Po battery back.

TUNING, ADJUSTING & MAINTAINING YOUR VEHICLE

- Examine your vehicle on a regular basis.
- Use a brush to remove dirt and dust.
- Look for damage to the suspension arms and other molded parts.
- Re-glue the tires to the wheels, if necessary.
- Use suitable tools to tighten fasteners.
- Make sure the camber and steering linkages are not bent. Replace any bent linkages.
- Remove the shocks and inspect them for damage. Rebuild the shocks if oil is leaking.
- Inspect electronics and batteries for exposed wires. Repair exposed wires with shrink-wrap or replace the wire.
- Make sure the ESC and receiver are secure on the chassis. Replace the double-sided tape, if necessary.
- Power on the transmitter. If the green LED is dim or off, replace the AA batteries in your transmitter.
- Check the spur gear for wear.

CHANGING THE TRAVEL ADJUST SETTINGS



WARNING: Unplug 2 of the 3 motor wires to prevent the car from running away when setting the EPA (travel).

1. Hold the trigger in the full brake position and the steering wheel full right while powering on the transmitter. The LED flashes rapidly, indicating the programming mode is active.
2. **Throttle End Point:** Hold the throttle trigger to full throttle while turning the TH TRIM

knob clockwise until it stops. Turn the TH TRIM knob to adjust the full throttle end point.

3. **Brake End Point:** Hold the trigger in the full brake position. Turn the TH TRIM knob clockwise until it stops. Return the trigger to the center position.
4. **Left Steering End Point:** Hold the steering wheel in the full left position. Turn the ST TRIM knob to adjust the left end point.
5. **Right Steering End Point:** Hold the steering wheel in the full right position. Turn the ST TRIM knob to adjust the right end point. Return the steering wheel to the center position.
6. Power off the transmitter to save the travel adjust settings.

The minimum Travel is 75%, and the Maximum travel is 150%.

SERVICE/REPAIR

RADIO/SPEED CONTROL & MOTOR

If any problems other than those covered in the troubleshooting section arise, please call the appropriate electronics service department. They will be able to give the problem additional specific attention and provide instructions for the solution.

MAINTENANCE

If any questions other than those covered in the troubleshooting or maintenance sections arise, please call the appropriate Horizon product support department.

CLEANING

Performance can be hindered if dirt gets in any of the moving suspension parts. Use compressed air, a soft paintbrush, or a toothbrush to remove dust or dirt. Avoid using solvents or chemicals as they can actually wash dirt into the bearings or moving parts, as well as cause damage to the electronics.

TROUBLESHOOTING GUIDE

PROBLEM	POSSIBLE CAUSE	SOLUTION
Vehicle does not operate	Battery not charged or plugged in	Charge battery or plug in
	ESC switch not ON	Turn on ESC switch
	Transmitter not ON or low battery	Turn on or replace battery
Motor runs but wheels do not rotate	Pinion not meshing with spur gear	Adjust pinion/spur mesh
	Pinion spinning on motor shaft	Tighten pinion gear setscrew on motor shaft flat spot
	Transmission gears stripped	Replace transmission gears
	Drive pin broken	Check and replace drive pin
Steering does not work	Servo plug not in receiver properly	Make sure the steering servo plug is connected to the receiver steering channel, noting proper polarity
	Servo gears or motor damaged	Replace or repair servo
Will not turn one direction	Servo gears damaged	Replace or repair servo
Motor does not run	Motor wire solder joint is damaged	Resolder the motor wire with the proper equipment
	Motor wire broken	Repair or replace as needed
	ESC damaged	Contact Horizon Hobby Product Support
ESC gets hot	Motor over-gearred	Use smaller pinion or larger spur gear
	Driveline bound up	Check wheels and transmission for binding
Poor run time and/or sluggish acceleration	Battery pack not fully charged	Recharge battery
	Charger not allowing full charge	Try another charger
	Driveline bound up	Check wheels, transmission for binding
Poor range and/or glitching	Transmitter batteries low	Check and replace
	Vehicle battery low	Recharge battery
	Loose plugs or wires	Check all wire connections and plugs

LIMITED WARRANTY

What this Warranty Covers

Horizon Hobby, LLC, (Horizon) warrants to the original purchaser that the product purchased (the "Product") will be free from defects in materials and workmanship at the date of purchase.

What is Not Covered

This warranty is not transferable and does not cover (i) cosmetic damage, (ii) damage due to acts of God, accident, misuse, abuse, negligence, commercial use, or due to improper use, installation, operation or maintenance, (iii) modification of or to any part of the Product, (iv) attempted service by anyone other than a Horizon Hobby authorized service center, (v) Product not purchased from an authorized Horizon dealer, or (vi) Product not compliant with applicable technical regulations or (vii) use that violates any applicable laws, rules, or regulations.

OTHER THAN THE EXPRESS WARRANTY ABOVE, HORIZON MAKES NO OTHER WARRANTY OR REPRESENTATION, AND HEREBY DISCLAIMS ANY AND ALL IMPLIED WARRANTIES, INCLUDING, WITHOUT LIMITATION, THE IMPLIED WARRANTIES OF NON-INFRINGEMENT, MERCHANTABILITY AND FITNESS FOR A PARTICULAR PURPOSE. THE PURCHASER ACKNOWLEDGES THAT THEY ALONE HAVE DETERMINED THAT THE PRODUCT WILL SUITABLY MEET THE REQUIREMENTS OF THE PURCHASER'S INTENDED USE.

Purchaser's Remedy

Horizon's sole obligation and purchaser's sole and exclusive remedy shall be that Horizon will, at its option, either (i) service, or (ii) replace, any Product determined by Horizon to be defective. Horizon reserves the right to inspect any and all Product(s) involved in a warranty claim. Service or replacement decisions are at the sole discretion of Horizon. Proof of purchase is required for all warranty claims. SERVICE OR REPLACEMENT AS PROVIDED UNDER THIS WARRANTY IS THE PURCHASER'S SOLE AND EXCLUSIVE REMEDY.

Limitation of Liability

HORIZON SHALL NOT BE LIABLE FOR SPECIAL, INDIRECT, INCIDENTAL OR CONSEQUENTIAL DAMAGES, LOSS OF PROFITS OR PRODUCTION OR COMMERCIAL LOSS IN ANY WAY, REGARDLESS OF WHETHER SUCH CLAIM IS BASED IN CONTRACT, WARRANTY, TORT, NEGLIGENCE, STRICT LIABILITY OR ANY OTHER THEORY OF LIABILITY, EVEN IF HORIZON HAS BEEN ADVISED OF THE POSSIBILITY OF SUCH DAMAGES. Further, in no event shall the liability of Horizon exceed the individual price of the Product on which liability is asserted. As Horizon has no control over use, setup, final assembly, modification or misuse, no liability shall be assumed nor accepted for any resulting damage or injury. By the act of use, setup or assembly, the user accepts all resulting liability. If you as the purchaser or user are not prepared to accept the liability associated with the use of the Product, purchaser is advised to return the Product immediately in new and unused condition to the place of purchase.

Law

These terms are governed by Illinois law (without regard to conflict of law principals). This warranty gives you specific legal rights, and you may also have other rights which vary from state to state. Horizon reserves the right to change or modify this warranty at any time without notice.

WARRANTY SERVICES

Questions, Assistance, and Services

Your local hobby store and/or place of purchase cannot provide warranty support or service. Once assembly, setup or use of the Product has been started, you must contact your local distributor or Horizon directly. This will enable Horizon to better answer your questions and service you in the event that you may need any assistance. For questions or assistance, please visit our website at www.horizonhobby.com, submit a Product Support Inquiry, or call the toll free telephone number referenced in the Warranty and Service Contact Information section to speak with a Product Support representative.

Inspection or Services

If this Product needs to be inspected or serviced and is compliant in the country you live and use the Product in, please use the Horizon Online Service Request submission process found on our website or call Horizon to obtain a Return Merchandise Authorization (RMA) number. Pack the Product securely using a shipping carton. Please note that original boxes may be included, but are not designed to withstand the rigors of shipping without additional protection. Ship via a carrier that provides tracking and insurance for lost or damaged parcels, as Horizon is not responsible for merchandise until it arrives and is accepted at our facility. An Online Service Request is available at http://www.horizonhobby.com/content/service-center_render-service-center. If you do not have internet access, please contact Horizon Product Support to obtain a RMA number along with instructions for submitting your product for service. When calling Horizon, you will be asked to provide your complete name, street address, email address and phone number where you can be reached during business hours. When sending product into Horizon, please include your RMA number, a list of the included items, and a brief summary of the problem. A copy of your original sales receipt must be included for warranty consideration. Be sure your name, address, and RMA number are clearly written on the outside of the shipping carton.

NOTICE: Do not ship Li-Po batteries to Horizon. If you have any issue with a Li-Po battery, please contact the appropriate Horizon Product Support office.

Warranty Requirements

For Warranty consideration, you must include your original sales receipt verifying the proof-of-purchase date. Provided warranty conditions have been met, your Product will be serviced or replaced free of charge. Service or replacement decisions are at the sole discretion of Horizon.

Non-Warranty Service

Should your service not be covered by warranty, service will be completed and payment will be required without notification or estimate of the expense unless the expense exceeds 50% of the retail purchase cost. By submitting the item for service you are agreeing to payment of the service without notification. Service estimates are available upon request. You must include this request with your item submitted for service. Non-warranty service estimates will be billed a minimum of ½ hour of labor. In addition you will be billed for return freight. Horizon accepts money orders and cashier's checks, as well as Visa, MasterCard, American Express, and Discover cards. By submitting any item to Horizon for service, you are agreeing to Horizon's Terms and Conditions found on our website http://www.horizonhobby.com/content/service-center_render-service-center.



ATTENTION: Horizon service is limited to Product compliant in the country of use and ownership. If received, a non-compliant Product will not be serviced. Further, the sender will be responsible for arranging return shipment of the un-serviced Product, through a carrier of the sender's choice and at the sender's expense. Horizon will hold non-compliant Product for a period of 60 days from notification, after which it will be discarded.

10/15

WARRANTY AND SERVICE CONTACT INFORMATION

COUNTRY OF PURCHASE	HORIZON HOBBY	CONTACT INFORMATION	ADDRESS
United States of America	Horizon Service Center (Repairs and Repair Requests)	servicecenter.horizonhobby.com/RequestForm/	4105 Fieldstone Rd Champaign, Illinois, 61822 USA
	Horizon Product Support (Product Technical Assistance)	productsupport@horizonhobby.com 877-504-0233	
	Sales	websales@horizonhobby.com 888-338-4639	
EU	Horizon Technischer Service Sales: Horizon Hobby GmbH	service@horizonhobby.eu +49 (0) 4121 2655 100	Hanskampring 9 D 22885 Barsbüttel, Germany

FCC INFORMATION

FCC ID: BRWDSTX1 | BRWDASRX18 This device complies with part 15 of the FCC rules. Operation is subject to the following two conditions: (1) This device may not cause harmful interference, and (2) this device must accept any interference received, including interference that may cause undesired operation.



CAUTION: Changes or modifications not expressly approved by the party responsible for compliance could void the user's authority to operate the equipment.

This product contains a radio transmitter with wireless technology which has been tested and found to be compliant with the applicable regulations governing a radio transmitter in the 2.400 GHz to 2.4835 GHz frequency range.

ANTENNA SEPARATION DISTANCE

When operating your Spektrum transmitter, please be sure to maintain a separation distance of at least 5 cm between your body (excluding fingers, hands, wrists, ankles and feet) and the antenna to meet RF exposure safety requirements as determined by FCC regulations.

The following illustrations show the approximate 5 cm RF exposure area and typical hand placement when operating your Spektrum transmitter.

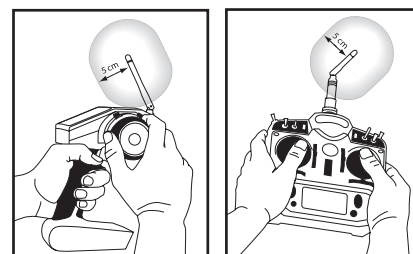

IC INFORMATION

IC: 6157A-STX1 | 6157A-ASRX18 This device complies with Industry Canada licence-exempt RSS standard(s). Operation is subject to the following two conditions: (1) this device

may not cause interference, and (2) this device must accept any interference, including interference that may cause undesired operation of the device.

CE EU Compliance Statement: Horizon Hobby, LLC hereby declares that this product is in compliance with the essential requirements and other relevant provisions of the RED and EMC directives.

A copy of the EU Declaration of Conformity is available online at: <http://www.horizonhobby.com/content/support-render-compliance>.



Instructions for disposal of WEEE by users in the European Union

This product must not be disposed of with other waste. Instead, it is the user's responsibility to dispose of their waste equipment by handing it over to a designated collections point for the recycling of waste electrical and electronic equipment. The separate collection and recycling of your waste equipment at the time of disposal will help to conserve natural resources and ensure that it is recycled in a manner that protects human health and the environment. For more information about where you can drop off your waste equipment for recycling, please contact your local city office, your household waste disposal service or where you purchased the product.

REPLACEMENT PARTS | ERSATZTEILE | PIÈCES DE RECHANGE | PEZZI DI RICAMBIO

Part #	English	Deutsch	Français	Italiano
DYN4955	130A WP Dynamite ESC	Fuze 130A bürstenloser, wasserdichte Geschwindigkeitsregler	Contrôleur étanche Brushless Fuze 130A	ESC Fuze waterproof brushless 130 A
DYNS1805	Fuze 1/8 BL Motor: 2500Kv	Fuze bürstenloser Motor im Maßstab 1:8: 2500 kv	Moteur BL Fuze 1/8, 2500Kv	Motore Fuze brushless 1/8: 2500 Kv
LOS240009	Body, Cf, Painted: 8IGHT-E RTR	Karosserie, CF, lackiert: 8IGHT-E RTR	8IGHT-E RTR - Carrosserie Cab forward peinte	Carrozzeria, cab forward, verniciata: 8IGHT-E RTR
LOS242013	Fr 47T Gear, 12 TPIn: 8/8T RTR	47T Frontgetriebe, 12T-Stift: 8/8T RTR	8/8T RTR - Différentiel avant 47T et pignon 12T	Corona anteriore 47 denti, pignone 12 denti: 8/8T RTR
LOS242014	Rr 47T Gear, 12T Pin: 8/8T RTR	47T Heckgetriebe, 12T-Stift: 8/8T RTR	8/8T RTR - Différentiel arrière 47T et pignon 12T	Corona posteriore 47 denti, pignone 12 denti: 8/8T RTR
LOS242015	Diff Case & Hdwr: 8/8T RTR	Ausgleichsgehäuse und Hardware: 8/8T RTR	8/8T RTR - Corps de différentiel	Scatola differenziale e accessori: 8/8T RTR
LOS242016	Center Outdrives (2): 8/8T RTR	Mittenabtriebe (2) 8/8T RTR	8/8T RTR - Noix de cardans centraux (2)	Trascinatori centrali (2): 8/8T RTR
LOS242017	Fr/Rr Outdrives (2): 8/8T RTR	Front-/Heckabtriebe (2) 8/8T RTR	8/8T RTR - Noix de cardans avant/arrière (2)	Trascinatori ant./post. (2): 8/8T RTR
LOS243002	15mm Shock Body St, Fr (2): 8 RTR	15 mm Stoßdämpfergehäuse, Front (2): 8 RTR	8IGHT RTR - Corps d'amortisseurs avant 15mm (2)	Set corpo ammortizzatore 15 mm, anteriore (2): 8 RTR
LOS243004	8T Fr, 8 Rr Shk Body: 8/8T RTR	8T Front-, 8 Heck-Stoßdämpfergehäuse: 8/8T RTR	8/8T RTR - Corps d'amortisseur avant 8T et arrière 8 (2)	Corpo ammortizzatore anteriore 8T, posteriore 8: 8/8T RTR
LOS243005	Shock Caps (2): 8/8T RTR	Stoßdämpferkappen (2): 8/8T RTR	8/8T RTR - Bouchons d'amortisseurs (2)	Cappucci ammortizzatore (2): 8/8T RTR
LOS244000	Link Set: 8IGHT RTR	Gestängesatz: 8IGHT RTR	8IGHT RTR - Biellettes	Set collegamenti: 8IGHT RTR
LOSA1701	Front Suspension Arm Bushings: 8B/8T	Buchsen Arm vordere Aufhängung: 8B/8T	8B/8T - Bagues de triangle av	Boccole braccio sospensione anteriore: 8B/8T
LOSA1731	R Hub Carriers: 8B 2.0	R Radträger: 8B 2.0	8B 2.0 - Porte moyeu arrière	Portamozzi posteriori: 8B 2.0
LOSA1750	Sway Bar Set: 8B/8T	Stabilisatorsatz: 8B/8T	8B/8T - Jeu de barre anti-roulis	Set barra antitorione: 8B/8T
LOSA3518	Drive Pin Set: 8B/8T	Mitnehmerstiftsatz: 8B/8T	8B/8T - Goupilles	Set perno guida: 8B/8T
LOSA3522	F/R CV Driveshaft Axles (2): 8B/8T	Front/Heck CV-Antriebswellenachsen (2): 8B/8T	8B/8T - Axes de cardans av/arr CV (2)	Assi trasmissione CV ant./post. (2): 8B/8T
LOSA3523	F/R CV Driveshaft Coupling Set: 8B/8T	Front/Heck CV-Antriebswellenkupplungssatz: 8B/8T	8B/8T - Coupleurs de cardans av/arr CV	Set accoppiatore trasmissione CV ant./post.: 8B/8T
LOSA3530	Wheel Hexes (Pr) Hard Ano: 8B/8T	Radsechskante (Pr) Hardware Ano: 8B/8T	8B/8T - Hexagone de Jantes (Pr) anodisé dur	Esagoni ruote (Pr) anodizzati: 8B/8T
LOSA3531	Wheel Nuts & Pins (4): 8B, 8T	Radmuttern und Stifte (4): 8B/8T	8B/8T - Ecrous de jantes & goupilles (4)	Dadi e perni ruote (4): 8B/8T
LOSA3535	F/R CV Drive Shafts (2): 8B 2.0	Front/Heck CV-Antriebswellen (2): 8B 2.0	8B 2.0 - Arbres av/arr. CV (2)	Alberi trasmissione CV ant./post. (2): 8B 2.0
LOSA3577	1.0 Module Pitch Pinion, 17T: 8E, SCTE	1.0 Modul Zahnritzel, 17T: 8E, SCTE	8E, SCTE - Pignon module 1.0, 17T	Pignone a passo modulare 1.0, 17 denti: 8E, SCTE
LOSA4002	Antenna Kit	Antennensatz	Kit antenne	Kit antenna
LOSA4003	Antenna Caps	Antennenkappen	Embouts d'antenne	Cappucci antenna
LOSA4406	Steering Bell Crank Plstc & Servo Svr 2.0	Steuer-Umlenkhebel Kunststoff und Servo Svr. 2.0	Palonnier de direction, plastiques & sauve servo: 2.0	Squadretta sterzo plastica e salvaservo 2.0
LOSA4408	Steering Post Set: 8B/8T	Lenksäulensatz: 8B/8T	8B/8T - Pivot de direction	Set comandi sterzo: 8B/8T
LOSA4420	Center Diff Mnt & Brace Set: 8B 2.0	Mitteldifferentials-Halterung und Stützsatz: 8B 2.0	8B 2.0 - Support de diff cent. & entretoises	Set supporto e montante differenziale centrale: 8B 2.0
LOSA4424	Body Posts & Tank Mounts: 8B/8T	Karosserieträger und Motorhalterungen: 8B/8T	8B/8T - Plots de carrosseries & support de réservoir	Supporti carrozzeria e serbatoio: 8B/8T
LOSA4431	Hinge Pin Brace Cover Set: 8B/8T	Scharnierbolzen Stützabdeckungssatz: 8B/8T	8B/8T - Support d'axes	Set protezioni piastrine: 8B/8T
LOSA4435	Wing Mount Set: 8B/8T	Flügelhalterungssatz: 8B/8T	8B/8T - Support d'aileron	Set supporto alettone: 8B/8T
LOSA4453	Chassis Spacer/Cap Set: 8B 2.0	Karosserie Distanzstück/Kappen-Satz: 8B 2.0	8B 2.0 - Châssis entretoise/bouchon	Set distanziali/cappucci telaio: 8B 2.0
LOSA4454	R Gearbox Bearing Inserts, Alum	Heckgetriebe Lagereinsätze, Aluminium	Bague de roulement de diff arr., alu	Inserti cuscinetti posteriori scatola del cambio, alluminio
LOSA5411	15 mm Shock Shaft 4 x 50 mm, TiN (1): 8B/8T	15 mm Stoßdämpferwelle 4 x 50 mm, TiN (1): 8B/8T	8B/8T - Tige d'amortisseur 15 mm 4 x 50 mm, Tri-nitride. (1)	Albero ammortizzatore 15 mm 4 x 50 mm, TiN (1): 8B/8T
LOSA5413	15 mm Shock Shaft 4 x 57 mm, TiN (1): 8B/8T	15 mm Stoßdämpferwelle 4 x 57 mm, TiN (1): 8B/8T	8B/8T - Tige d'amortisseur 15 mm 4 x 57 mm, Tri-nitride. (1)	Albero ammortizzatore 15 mm 4 x 57 mm, TiN (1): 8B/8T
LOSA5429	Shock O-ring Set: 8B/8T	Stoßdämpfer O-Ring-Satz: 8B/8T	8B/8T - Joints toriques amortisseurs	Set o-ring ammortizzatori: 8B/8T
LOSA5430	15mm Shock Bladders: 8B/8T	15 mm Stoßdämpfersäcke: 8B/8T	8B/8T - Coupelles de volume constant d'amortisseur 15mm	Membrane ammortizzatore 15 mm: 8B/8T
LOSA5435	15mm Shock Ends,Cups,Bushing: 8B 2.0	15 mm Stoßdämpferenden, Dichtung, Buchsen: 8B 2.0	8B 2.0 - Rotules, coupelles, bagues d'amortisseurs 15mm	Boccole, coppe, terminali ammortizzatore 15 mm: 8B 2.0

REPLACEMENT PARTS | ERSATZTEILE | PIÈCES DE RECHANGE | PEZZI DI RICAMBIO

Part #	English	Deutsch	Français	Italiano
LOSA5440	15 mm Shock Piston/Guide Set: 8B/8T	15 mm Stoßdämpferkolben/Führungssatz: 8B/8T	8B/8T - Piston/Guide d'amortisseurs 15 mm	Set guida/pistone ammortizzatori 15 mm: 8B/8T
LOSA5451	15 mm Springs 2.3" x 4.4 Rate, Silver	15 mm Federn 2,3" x 4,4 Verhältnis, Silber	15 mm Ressorts 2.3 x Dureté 4.4, argentés	Molle 15 mm, rigidezza 2,3" x 4,4, argento
LOSA5458	15 mm Springs 3.1" x 3.1 Rate, Green	15 mm Federn 3,1" x 3,1 Verhältnis, Grün	15 mm Ressorts 3.1" x Dureté 3.1 verts	Molle 15 mm, rigidezza 3,1" x 3,1, verde
LOSA6045	HD Steering Link Set: 8B 2.0	HD-Lenkgestängesatz: 8B 2.0	8B 2.0 - Tringlerie de dir. renf.	Set collegamenti sterzo HD: 8B 2.0
LOSA6048	Susp. Balls 8.8 mm Flanged: 8B/8T	Federkugeln, 8,8 mm geflanscht: 8B/8T	8B/8T - Billes de susp. 8,8mm flasqué	Sfere sospensioni 8,8 mm, flangiate: 8B/8T
LOSA6050	Steering Ball Set 6.8 mm: 8B/8T	Kugelumlaufsatz 6,8 mm: 8B/8T	8B/8T - Billes de direction 6.8mm	Set sfere sterzo 6,8 mm: 8B/8T
LOSA6056	Suspension Balls 6.8 mm: 8B 2.0	Federkugeln 6,8 mm: 8B 2.0	8B 2.0 - Billes de susp. 6.8mm	Sfere sospensioni 6,8 mm: 8B 2.0
LOSA6221	4-40 x 5/8" Cap Screws	4-40 x 5/8" Kopfschrauben	Vis CHC 4-40 x 5/8"	Viti a testa cilindrica con esagono incassato 4-40 x 5/8"
LOSA6227	Hardened Setscrews, 4-40	Gehärtete Feststellschrauben, 4-40	Vis durcies, 4-40	Grani induriti, 4-40
LOSA6240	5-40 x 1/2" Caphead Screw (8)	5-40 x 1/2" Kopfschrauben (8)	Vis CHC 5-40 x 1/2" (8)	Vite a testa cilindrica con esagono incassato 5-40 x 1/2" (8)
LOSA6241	5-40 x 5/8" Caphead Screw (8)	5-40 x 5/8" Kopfschrauben (8)	Vis CHC 5-40 x 5/8" (8)	Vite a testa cilindrica con esagono incassato 5-40 x 5/8" (8)
LOSA6251	5-40 x 3/16" Set Screw (10)	5-40 x 3/16" Feststellschrauben (10)	Vis 5-40 x 3/16" (10)	Grano 5-40 x 3/16" (10)
LOSA6255	2.56 x 1/4" Button Head Screw (10)	2,56 x 1/4" Halbrundschraben (10)	Vis à tête bombée 2,56 x 1/4" (10)	Vite a testa tonda 2,56 x 1/4" (10)
LOSA6256	4-40 x 1/2" Button Head Cap Screw (6)	4-40 x 1/2" Halbrundschraben (6)	Vis à tête bombée 4-40 x 1/2" (6)	Vite a testa tonda 4-40 x 1/2" (6)
LOSA6262	8-32 x 1/2" FH Screws (10)	8-32 x 1/2" Flachkopfschrauben (10)	Vis FH 8-32 x 1/2" (10)	Viti a testa piatta 8-32 x 1/2" (10)
LOSA6263	8-32 x 3/4" BH Screws (8)	8-32 x 3/4" Halbrundschraben (8)	Vis BH 8-32 x 3/4" (8)	Viti a testa tonda 8-32 x 3/4" (8)
LOSA6266	8-32 x 5/8" BH Screws	8-32 x 5/8" Halbrundschraben	Vis BH 8-32 x 5/8"	Viti a testa tonda 8-32 x 5/8"
LOSA6270	5-40 x 3/8" Flat Head Screws (10)	5-40 x 3/8" Flachkopfschrauben (10)	Vis à tête fraisée 5-40 x 3/8" (10)	Viti a testa piatta 5-40 x 3/8" (10)
LOSA6271	5-40 x 1/2" FH Screws (10)	5-40 x 1/2" Flachkopfschrauben (10)	Vis FH 5-40 x 1/2" (10)	Viti a testa piatta 5-40 x 1/2" (10)
LOSA6272	5-40 x 3/4" FH Screws (10)	5-40 x 3/4" Flachkopfschrauben (10)	Vis FH 5-40 x 3/4" (10)	Viti a testa piatta 5-40 x 3/4" (10)
LOSA6273	5-40 x 7/8" FH Screws (4)	5-40 x 7/8" Flachkopfschrauben (4)	Vis FH 5-40 x 7/8" (4)	Viti a testa piatta 5-40 x 7/8" (4)
LOSA6274	5-40 x 1 7/8" FH Screws (2)	5-40 x 1 7/8" Flachkopfschrauben (2)	Vis FH 5-40 x 1 7/8" (2)	Viti a testa piatta 5-40 x 1 7/8" (2)
LOSA6278	5-40 x 1/2" BH Screws (8)	5-40 x 1/2" Halbrundschraben (8)	Vis BH 5-40 x 1/2" (8)	Viti a testa tonda 5-40 x 1/2" (8)
LOSA6279	5-40 x 3/4" BH Screws (8)	5-40 x 3/4" Halbrundschraben (8)	Vis BH 5-40 x 3/4" (8)	Viti a testa tonda 5-40 x 3/4" (8)
LOSA6280	5-40 x 1" BH Screws (4)	5-40 x 1" Halbrundschraben (4)	Vis BH 5-40 x 1" (4)	Viti a testa tonda 5-40 x 1" (4)
LOSA6281	5-40 x 20 mm Button Head Screws (10)	5-40 x 20 mm Halbrundschraben (10)	Vis à tête bombée 5-40 x 20 mm (10)	Viti a testa tonda 5-40 x 20 mm (10)
LOSA6282	5-40 x 7/8" BH Screws	5-40 x 7/8" Halbrundschraben	Vis BH 5-40 x 7/8"	Viti a testa tonda 5-40 x 7/8"
LOSA6284	5-40 x 20 mm BHS, Left Hand Thread, 8B	5-40 x 20 mm Halbrundschraben, Linksgewinde, 8B	8B - Vis CHC pas inverse 5-40 x 20 mm	Viti a testa tonda 5-40 x 20 mm, filettatura sinistrorsa, 8B
LOSA6286	5-40 x 5/8 BH Screws (8)	5-40 x 5/8 Halbrundschraben (8)	Vis BH 5-40 x 5/8 (8)	Viti a testa tonda 5-40 x 5/8 (8)
LOSA6296	8-32 x 1/8 Flat Point Setscrew-8	8-32 x 1/8 Flachkopfschrauben -8	8 - Vis pointeau bout plat 8-32 x 1/8	Grano con punta piana 8-32 x 1/8, 8
LOSA6297	5-40 x 1/8 Flat Point Setscrew-8	5-40 x 1/8 Flachkopfschrauben -8	8 - Vis pointeau bout plat 5-40 x 1/8	Grano con punta piana 5-40 x 1/8, 8
LOSA6302	5-40 Locking Nuts, Steel	5-40 Kontermuttern, Stahl	Écrou acier 5-40	Dadi autobloccanti 5-40, acciaio
LOSA6306	4-40 Aluminum Mini-Nuts (10)	4-40 Aluminium Mini-Muttern (10)	Mini écrou alu 4-40 (10)	Dadi mini, alluminio 4-40 (10)
LOSA6311	8-32 Steel Lock Nuts (10)	8-32 Stahl Kontermuttern (10)	Écrou acier 8-32 (10)	Dadi autobloccanti 8-32, acciaio (10)
LOSA6350	#4 and 1/8" Hardened Washers	Nr. 4 und 1/8" gehärtete Unterlegscheiben	Rondelles durcies #4 et 1/8"	Rondelle indurite n. 4 e 1/8"
LOSA6945	8 x 14 x 4 Rubber Sealed BB (4)	8 x 14 x 4 mit Gummi abgedichtete Kugellager (4)	Roulements étanches caoutchouc 8 x 14 x 4 (4)	Cuscinetto a sfera sigillato in gomma 8 x 14 x 4 (4)
LOSA6946	6 x 10 x 3 Rubber Sealed BB (4)	6 x 10 x 3 mit Gummi abgedichtete Kugellager (4)	Roulements étanches caoutchouc 6 x 10 x 3 (4)	Cuscinetto a sfera sigillato in gomma 6 x 10 x 3 (4)
LOSA6947	5 x 11 x 4 Rubber Sealed BB (4)	5 x 11 x 4 mit Gummi abgedichtete Kugellager (4)	Roulements étanches caoutchouc 5 x 11 x 4 (4)	Cuscinetto a sfera sigillato in gomma 5 x 11 x 4 (4)
LOSA6953	1/2 x 3/4 Rubber Sealed BB	1/2 x 3/4 mit Gummi abgedichtete Kugellager	Roulements étanches caoutchouc 1/2 x 3/4	Cuscinetto a sfera sigillato in gomma 1/2 x 3/4
LOSA8131	8IGHT Wing, White: 8B, 8T	8IGHT Flügel, weiß: 8B, 8T	8B, 8T - Aileron 8IGHT, blanc	Alettone 8IGHT, bianco: 8B, 8T
LOSA99041	Metal Sx Arm Insert, 23 Spline, JR (2)	Metall Sx Armeinsatz, 23 Spline, JR (2)	Insert 23s JR pour bras de servo métal (2)	Inserto squadretta servo, metallo, 23 scanalature, JR (2)
LOSB2203	Hinge Pin Brace Set: 8 RTR	Scharnierbolzen Stützsatz: 8 RTR	8 RTR - Jeu de support d'axe	Set piastrine: 8 RTR
SPMS605	9KG Servo, WP, Metal, 23T	9KG Servo, wasserdicht, 23T	Servo étanche 9kg, 23T	Servo 9kg, waterproof, 23T

REPLACEMENT PARTS | ERSATZTEILE | PIÈCES DE RECHANGE | PEZZI DI RICAMBIO

Part #	English	Deutsch	Français	Italiano
SPMSR310	SR310 DSMR 3-Channel Receiver	SR310 3-Kanal DSMR Oberflächenempfänger	Récepteur SR310 3 voies DSMR	Ricevente di superficie SR310 DSMR 3 canali
TLR241001	Side Guards: 8E 3.0	Seitenschutz: 8E 3.0	8E 3.0 - Protections latérales	Protezioni laterali: 8E 3.0
TLR241003	Chassis Braces, Top Plate: 8E 3.0	Karosseriestreben, obere Platte: 8E 3.0	8E 3.0 - Renforts de châssis, platine supérieure	Montanti e coperchio superiore telaio: 8E 3.0
TLR241004	Servo Mount, Top Brace: 8E 3.0	Servohalterung, obere Strebe: 8E 3.0	8E 3.0 - Support de servo, renfort supérieur	Supporto servo, montante superiore: 8E 3.0
TLR241005	Front Bumper: 8E 3.0	Frontstoßstange: 8E 3.0	8E 3.0 - Pare choc avant	Paraurti anteriore: 8E 3.0
TLR241008	Battery Foam: 8E 3.0	Akku Schaumstoff: 8E 3.0	8E 3.0 - Mousse de batterie	Distanziale in espanso per batteria: 8E 3.0
TLR241012	Battery Tray: 8TE 3.0	Akkuhalterung: 8TE 3.0	8IGHT E 3.0 - Support batterie	Portabatteria: 8TE 3.0
TLR242002	Ctr Dogbone: 8B 3.0 (Rr), 8E 3.0 (FR)	Mittlerer Dogbone: 8B 3.0 (Heck), 8E 3.0 (Front)	8B 3.0 (Ar.), 8E 3.0 (av) - Cardan central	Cardano centrale: 8B 3.0 (post.), 8E 3.0 (ant.)
TLR242003	Coupler Outdrive: 8B 3.0	Kupplungsabtriebe: 8B 3.0	8B 3.0 - Noix d'accouplement de cardan	Accoppiatore trascinatore: 8B 3.0
TLR242007	Motor Mount 8E 3.0	Motorhalterung 8E 3.0	Support moteur 8 E 3.0	Supporto motore 8E 3.0
TLR242009	Rear Center Dog Bone: 8E 3.0	Hinterer mittlerer Dogbone: 8E 3.0	8E 3.0 - Cardan central arrière	Cardano centrale posteriore: 8E 3.0
TLR242013	Front & Rear Gear Box Set: All 8IGHT	Front- und Heckgetriebekastensatz: Alle 8IGHT	8IGHT - Set de cellules av et arr	Set scatola cambio ant. e post.: tutti i modelli 8IGHT
TLR242015	Motor Adapter, M4 Screw: 8E/8TE 3.0	Motoradapter, M4-Schraube: 8E/8TE 3.0	Adaptateur moteur à vis, M4 : 8E/8TE 3.0	Adattatore motore, vite M4: 8E/8TE 3.0
TLR243000	Shock Stand-off Set (2): 8B 3.0	Stoßdämpferabstandssatz (2): 8B 3.0	8B 3.0 - Entretoises d'amortisseurs (2)	Set distanziali ammortizzatori (2): 8B 3.0
TLR244000	Front Susp Arm Set: 8B 3.0	Vorderer Aufhängungsarmsatz: 8B 3.0	8B 3.0 - Jeu de bras de suspension avant	Set braccio sospensione ant.: 8B 3.0
TLR244001	Front Susp Arm Bush (4): 8B 3.0	Vorderer Aufhängungsarmbuchse (4): 8B 3.0	8B 3.0 - Jeu de paliers de bras de suspension avant (4)	Boccola braccio sospensione ant. (4): 8B 3.0
TLR244003	Front Spindle Set: 8B 3.0	Hauptspindelsatz: 8B 3.0	8B 3.0 - Jeu de fusées avant	Set fusello anteriore: 8B 3.0
TLR244004	FR Spndl Carrier, 15 Dgr: 8B 3.0	Hauptspindelträger, 15 Dgr: 8B 3.0	8B 3.0 - Etrier porte fusée avant, 15°	Portafusello anteriore, 15 gradi: 8B 3.0
TLR244005	Steer Rack St, BB, Shrt/Lg: 3.0	Lenkgestängesatz, Kugellager, kurz/lang: 3.0	8B 3.0 - Renvois de direction, courts/longs avec roulements	Set cremagliera sterzo, cuscinetti a sfera, corta/ lunga: 3.0
TLR244006	Ackerman Shoulder Screw (2): 8IGHT Buggy 3.0	Ackerman-Schulterschraube (2): 8IGHT Buggy 3.0	8B 3.0 - Vis épaulée de fixation de barre d'Ackerman (2)	Vite a perno per barra Ackerman (2): 8IGHT Buggy 3.0
TLR244007	Hinge Pins, 4 x 21mm, TiCn (2): 8B 3.0	Scharnierbolzen, 4 x 21 mm, TiCn (2): 8B 3.0	8B 3.0 - Axes en titane 4 x 21mm (2)	Perni, 4 x 21 mm, TiCn (2): 8B 3.0
TLR244008	Rr Susp Arm St: 8B 3.0	Hinterer Aufhängungsarmsatz: 8B 3.0	8B 3.0 - Jeu de bras de suspension arrière	Set braccio sospensione posteriore: 8B 3.0
TLR244011	Hinge Pin, 4 x 66mm, TiCn (2): 8B 3.0	Scharnierbolzen, 4 x 66 mm, TiCn (2): 8B 3.0	8B 3.0 - Axes de suspension en Titane 4 x 66mm (2)	Perno, 4 x 66 mm, TiCn (2): 8B 3.0
TLR244012	Otr Hng Pins, 3,5, TiCn (2): 8B 3.0	Äußere Scharnierbolzen, 3,5, TiCn (2): 8B 3.0	8B 3.0 - Axes de suspension extérieurs TiCn, 3,5mm (2)	Perni esterni, 3,5, TiCn (2): 8B 3.0
TLR244015	Rear Shock Tower: 8E 3.0	Hinterer Stoßdämpferbrücke: 8E 3.0	8E 3.0 - Support d'amortisseurs arrière	Torre ammortizzatore posteriore: 8E 3.0
TLR244025	Front Shock Tower: 8IGHT Buggy 4.0	Vordere Stoßdämpferbrücke: 8IGHT Buggy 4.0	8B 4.0 - Support d'amortisseurs avant	Torre ammortizzatore ant.: 8IGHT Buggy 4.0
TLR245000	Droop Screw (4): 8B 3.0	Droop-Schrauben (4): 8B 3.0	8B 3.0 - Vis de butée de suspension (4)	Vite del droop (4): 8B 3.0
TLR245001	5-40 x 1/4" FH Screws (10)	5-40 x 1/4" Flachkopfschrauben (10)	Vis FHC 5-40 x 1/4" (10)	Viti a testa piatta 5-40 x 1/4" (10)
TLR245003	M4 x 8 Socket Head Screws (10)	M4 x 8 Innensechskantschrauben (10)	Vis à pans creux M4 x 8 (10)	Vite a brugola M4 x 8 (10)
TLR342002	Rear Dogbone & Axle Set: 8B 3.0	Hinterer Dogbone und Achsensatz: 8B 3.0	8B 3.0 - Cardans et axes arrière (2)	Set cardano e asse posteriore: 8B 3.0
TLR44001	1/8 BX Dish Whl, Wht (4): 8B 3.0	1/8 BX Tellerscheibe, weiß (4): 8B 3.0	8B 3.0 - Jantes pleines Buggy, blanches (4)	Cerchione ruota BX 1/8, bianco (4): 8B 3.0
TLR5930	Cap Head Screws, M3 x 8 mm (10)	Kopfschrauben, M3 x 8 mm (10)	Vis BTR M3 x 8 mm (10)	Viti a testa cilindrica con esagono incassato, M3 x 8 mm (10)
TLR5933	Cap Head Screws, M3 x 12 mm (10)	Kopfschrauben, M3 x 12 mm (10)	Vis BTR M3 x 12 mm (10)	Viti a testa cilindrica con esagono incassato, M3 x 12 mm (10)
TLR6019	Ballstud/Hub Spacer St, Alum: 22	Kugelbolzen/Nabendistanzstücksatz, Aluminium: 22	22 - Rotules à visser et entretoises alu	Set distanziali per perno uniball/mozzo, alluminio: 22
TLR6352	Washers, M3 (10)	Unterlegscheiben, M3 (10)	Rondelles M3 (10)	Rondelle, M3 (10)
TLR8202	Body Clips, Black (12): 22	Karosserieklemmen, schwarz (12): 22	22 - Clips de carrosserie noirs (12)	Clip carrozzeria, nero (12): 22

RECOMMENDED PARTS | EMPFOHLENE TEILE | PIÈCES RECOMMANDÉES | PEZZI CONSIGLIATI

Part #	English	Deutsch	Français	Italiano
LOSA99172	Camber Gauge	Sturzmessgerät	Rapporteur de carrossage	Strumento regolazione campanatura
LOSA99173	Ride Height Gauge	Fahrhöhe-Messgerät	Rapporteur de garde au sol	Misuratore altezza da terra
LOSA99174	Car Stand: 8IGHT/T	Fahrzeugständer: 8IGHT/T	8IGHT/T - Banc de stand	Supporto automodello: 8IGHT/T
LOSA99176	Precision Tire Balancer w/Clay	Präzisions-Radausgleichsregler mit Lehm	Equilibreur de pneus avec de la pate	Bilanciatore gomme con plastilina modellabile
LOSB4604	17 mm Whl Wrench Anod Alum: LST2, MUG, 8B/8T	17 mm Radschraubenschlüssel Anod Aluminium: LST2, MUG, 8B/8T	LST2, MUG, 8B/8T - Clé à manche 17mm Anodisé Alum	Chiave ruote 17 mm, alluminio anodizzato: LST2, MUG, 8B/8T
TLR77000	High-Pressure Blk Grease, 8cc	Loses Hochdruckfett, 8 cc	Graisse noire haute pression, 8cc	Grasso sfuso alta pressione, 8 cc
TLR77001	Great Grease, 8cc	Great Grease, 8 cc	Graisse adhésive, 8cc	Great Grease, 8 cc
TLR77002	Shock O-ring Grease, 8cc	Stoßdämpfer O-Ring Fett, 8 cc	Graisse pour joint torique d'amortisseurs, 8cc	Grasso o-ring ammortizzatori, 8 cc
TLR99014	TLR Foam Pit Mat	TLR Schaumstoffmatte	Tapis de stand en mousse TLR	Tappetino spugna TLR
TLR99101	Shock Shaft Pliers	Stoßdämpferwelle Zange	Pince pour tige d'amortisseur	Pinze albero ammortizzatore
TLR99102	Turnbuckle Wrench, 22, 8B/8T	Spannschloss Schraubenschlüssel, 22, 8B/8T	22, 8B/8T - Clé à biellettes	Chiave tiranti filettati, 22, 8B/8T

OPTIONAL PARTS | OPTIONALE BAUTEILE | PIÈCES OPTIONNELLES | PEZZI OPZIONALI

Part #	English	Deutsch	Français	Italiano
DYN8264	SpeedTreads Robber 1/8 Buggy Tires, Mounted (2)	SpeedTreads Robber 1/8 Buggy Räder, befestigt (2)	Pneus Speedtreads Robber Buggy 1/8 montés sur jantes (2)	Pneumatici buggy SpeedTreads Robber 1/8, montati (2)
DYN8269	SpeedTreads RoadRunner 1/8 Buggy Tires, Mounted (2)	SpeedTreads RoadRunner 1/8 Buggy Räder, befestigt (2)	Speed Treads - Pneus Buggy 1/8 RoadRunner montés sur jantes (2)	Pneumatici buggy SpeedTreads RoadRunner 1/8, montati (2)
DYN8267	SpeedTreads Double Barrel 1/8 Buggy Tires, Mounted (2)	SpeedTreads Double Barrel 1/8 Buggy Räder, befestigt (2)	Speed Treads - Pneus Buggy 1/8 Double Barrel montés sur jantes (2)	Pneumatici buggy SpeedTreads Double Barrel 1/8, montati (2)
DYN8268	SpeedTreads Trigger 1/8 Buggy Tires, Mounted (2)	SpeedTreads Trigger 1/8 Buggy Räder, befestigt (2)	Speed Treads - Pneus Buggy 1/8 Trigger montés sur jantes (2)	Pneumatici buggy SpeedTreads Trigger 1/8, montati (2)
DYNW0001	SpeedTreads II Fullwick 1/8 Buggy Tires, Mounted (2)	SpeedTreads II Fullwick 1/8 Buggy Räder, befestigt (2)	Pneus Speedtreads II Fullwick pour Buggy 1/8 montés (2)	Pneumatici buggy SpeedTreads II Fullwick 1/8, montati (2)
DYNW0002	SpeedTreads II Gription, 1/8 Buggy Tires, Mounted (2)	SpeedTreads II Gription, 1/8 Buggy Räder, befestigt (2)	Pneus Speedtreads II Gription pour Buggy 1/8 montés (2)	Pneumatici buggy SpeedTreads II Gription, 1/8, montati (2)
DYNW0003	SpeedTreads II Dirtsmith, 1/8 Buggy Tires, Mounted (2)	SpeedTreads II Dirtsmith, 1/8 Buggy Räder, befestigt (2)	Pneus Speedtreads II Dirtsmith pour Buggy 1/8 montés (2)	Pneumatici buggy SpeedTreads II Dirtsmith, 1/8, montati (2)
DYNW0004	SpeedTreads II Dirtrage, 1/8 Buggy Tires, Mounted (2)	SpeedTreads II Dirtrage, 1/8 Buggy Räder, befestigt (2)	Pneus Speedtreads II Dirtrage pour Buggy 1/8 montés (2)	Pneumatici buggy SpeedTreads II Dirtrage, 1/8, montati (2)
LOSA1754	Adj Fr Hinge Pin Brace/Inserts: 8B/8T	Vordere Einpass-Scharnierbolzenstrebe/Einsätze: 8B/8T	8B/8T - Support d'axes avant réglable avec mousses	Piastrine anteriori regolabili con inserti: 8B/8T
LOSA3532	Wheel Hexes (4) + 2mm Wider: 8B/8T*	Radsechskante (4) + 2 mm breiter: 8B/8T*	8B/8T* - Hexagone de jantes (4) + 2mm	Esagoni ruote (4) larghi + 2 mm: 8B/8T*
LOSA3571	1.0 Module Pitch Pinion, 11T: 8E/SCTE	1.0 Modul Zahnritzel, 11T: 8E/SCTE	8E/SCTE - Pignon module 1.0, 11T	Pignone a passo modulare 1.0, 11 denti: 8E/SCTE
LOSA3572	1.0 Module Pitch Pinion, 12T: 8E/SCTE	1.0 Modul Zahnritzel, 12T: 8E/SCTE	8E/SCTE - Pignon module 1.0, 12T	Pignone a passo modulare 1.0, 12 denti: 8E/SCTE
LOSA3573	1.0 Module Pitch Pinion, 13T: 8E/SCTE	1.0 Modul Zahnritzel, 13T: 8E/SCTE	8E/SCTE - Pignon module 1.0, 13T	Pignone a passo modulare 1.0, 13 denti: 8E/SCTE
LOSA3574	1.0 Module Pitch Pinion, 14T: 8E/SCTE	1.0 Modul Zahnritzel, 14T: 8E/SCTE	8E/SCTE - Pignon module 1.0, 14T	Pignone a passo modulare 1.0, 14 denti: 8E/SCTE
LOSA3575	1.0 Module Pitch Pinion, 15T: 8E/SCTE	1.0 Modul Zahnritzel, 15T: 8E/SCTE	8E/SCTE - Pignon module 1.0, 15T	Pignone a passo modulare 1.0, 15 denti: 8E/SCTE
LOSA3576	1.0 Module Pitch Pinion, 16T: 8E/SCTE	1.0 Modul Zahnritzel, 16T: 8E/SCTE	8E/SCTE - Pignon module 1.0, 16T	Pignone a passo modulare 1.0, 16 denti: 8E/SCTE
LOSA3578	1.0 Module Pitch Pinion, 18T: 8E/SCTE	1.0 Modul Zahnritzel, 18T: 8E/SCTE	8E/SCTE - Pignon module 1.0, 18T	Pignone a passo modulare 1.0, 18 denti: 8E/SCTE
LOSA4440	Front Top Brace, Aluminum: 8B/8T	Vordere, obere Strebe, Aluminium: 8B/8T	8B/8T - Entretoise sup. av., alu	Montante superiore anteriore, alluminio: 8B/8T
LOSA4454	R Gearbox Bearing Inserts, Alum	Heckgetriebe Lagereinsätze, Aluminium	Bague de roulement de diff arr., alu	Inserti cuscinetti posteriori scatola del cambio, alluminio
LOSA8130	8IGHT Wing, Black: 8B/8T	8IGHT Flügel, schwarz: 8B/8T	8B/8T - Aileron 8IGHT, noir	Alettone 8IGHT, nero: 8B/8T
LOSA8132	1/8 Universal Wing Kit, Yellow	Universal Flügelsatz Maßstab 1:8, gelb	Kit Aileron Universel 1/8, jaune	Kit alettone universale 1/8, giallo
LOSA99030	Servo Arm, Aluminum: JR	Servoarm, Aluminium: JR	Palonnier de servo, alu: JR	Squadretta servo, alluminio: JR
LOSA99031	Servo Arm, Aluminum: KO/AIR/SPM	Servoarm, Aluminium: KO/AIR/SPM	Palonnier de servo, alu: KO/AIR/SPM	Squadretta servo, alluminio: KO/AIR/SPM
LOSA99032	Servo Arm, Aluminum: FUT	Servoarm, Aluminium: FUT	Palonnier de servo, alu: FUT	Squadretta servo, alluminio: FUT
LOSA99033	Servo Arm, Aluminum: Hitec	Servoarm, Aluminium: Hitec	Palonnier de servo, alu: Hitec	Squadretta servo, alluminio: Hitec
LOSA99040	Metal Sx Arm Insert, 23 Spline, AIR (2)	Metall Sx Armeinsatz, 23 Spline, AIR (2)	Insert 23s AIR pour bras de servo métal (2)	Inserto metallico squadretta servo, 23 scanalature, AIR (2)
LOSA99042	Metal Sx Arm Insert, 24 Spline, HRC (2)	Metall Sx Armeinsatz, 24 Spline, HRC (2)	Insert 24s HRC pour bras de servo métal (2)	Inserto metallico squadretta servo, 24 scanalature, HRC (2)
LOSA99043	Metal Sx Arm Insert, 25 Spline, FUT (2)	Metall Sx Armeinsatz, 25 Spline, FUT (2)	Insert 25s FUT pour bras de servo métal (2)	Inserto metallico squadretta servo, 25 scanalature, FUT (2)
TLR240001	Wing, Black 8IGHT Buggy 3.0	Flügel, schwarz 8IGHT Buggy 3.0	8B 3.0 - Aileron noir	Alettone, nero, 8IGHT Buggy 3.0
TLR240003	Wickerbill Set (2): 8IGHT Buggy 3.0	Wickerbill-Satz (2): 8IGHT Buggy 3.0	8B 3.0 - Jeu de rajouts d'aileron (2)	Set wickerbill (2): 8IGHT Buggy 3.0
TLR240007	Body Set, Clear: 8IGHT-E 4.0	Karoseriesatz, farblos: 8IGHT-E 4.0	8IGHT-E 4.0 - Carrosserie, transparente	Set carrozzeria, trasparente: 8IGHT-E 4.0
TLR244028	LRC Adj Rr Hinge Pin Brace St: 8/8T/4.0	LCR hintere Einpass-Scharnierbolzenstrebensatz: 8/8T/4.0	8/8T/4.0 - Cale de pincement arrière LRC	Set piastrine regolabili posteriori LRC: 8/8T/4.0
TLR342003	ElctrcClchSystem: 8E/8TE/3.0/8E 4.0	Elektrisches Steuerungssystem: 8E/8TE/3.0/8E 4.0	8E/8TE/3.0/8E 4.0 - Kit d'embrayage pour électrique	Frizione elettrica: 8E/8TE/3.0/8E 4.0
TLR344002	Al Fr Spindle Set: 8/T/E/4.0	Al Hauptspindelsatz: 8/T/E/4.0	8/T/E/4.0 - Set de fusées avant en aluminium	Set fusello anteriore, alluminio: 8/T/E/4.0
TLR344003	Al Rr Hub Carrier St: 8/T/E/4.0	Al Heck-Nabenträgersatz: 8/T/E/4.0	8/T/E/4.0 - Set d'étriers arrière en aluminium	Set portamozzo posteriore, alluminio: 8/T/E/4.0
TLR44000	1/8 BX Dish Whl, Yel (4): 8B/3.0	1/8 BX Tellerscheibe, gelb (4): 8B/3.0	8B/3.0 - Jantes pleines Buggy, jaunes (4)	Cerchione ruota BX 1/8, giallo (4): 8B/3.0

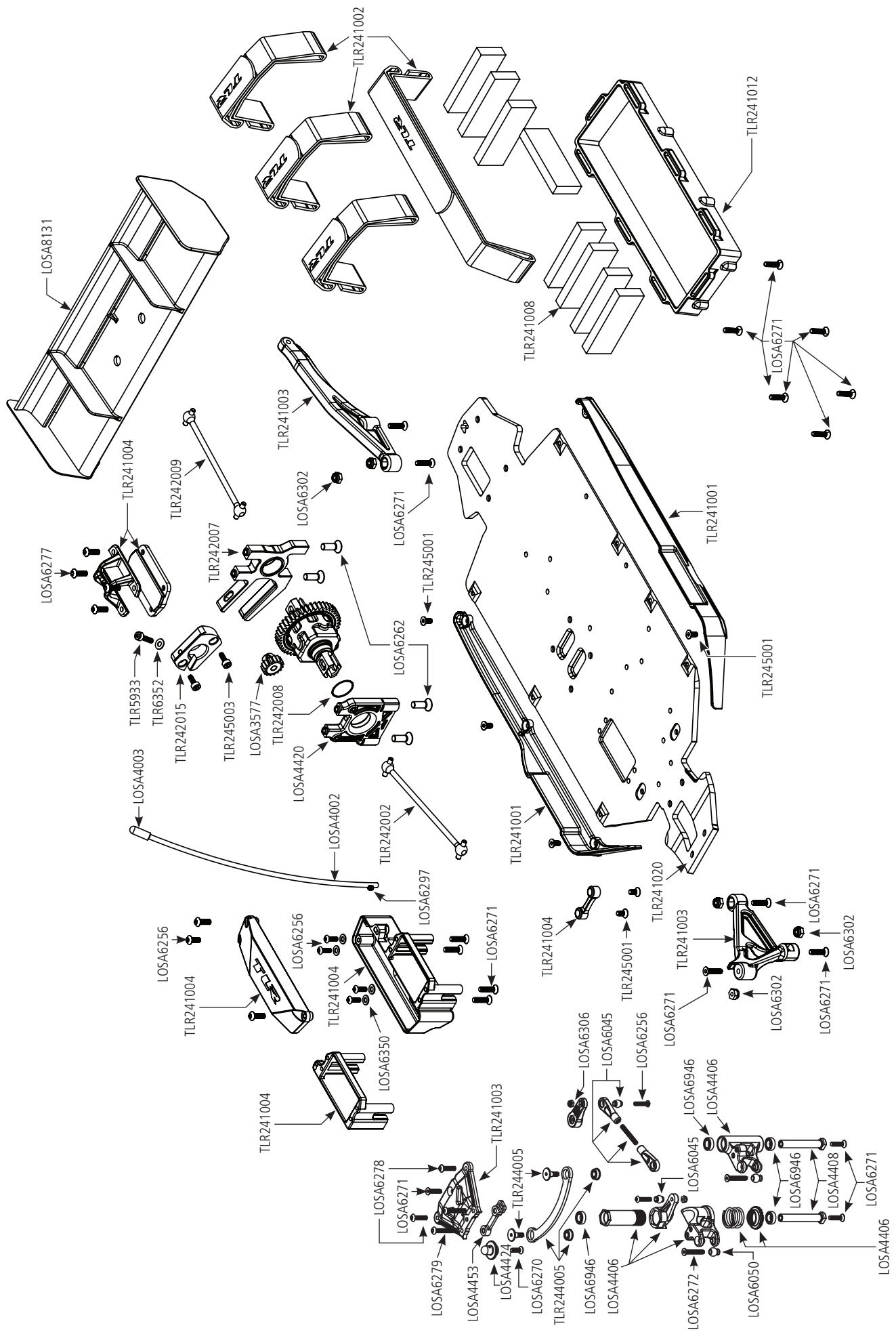

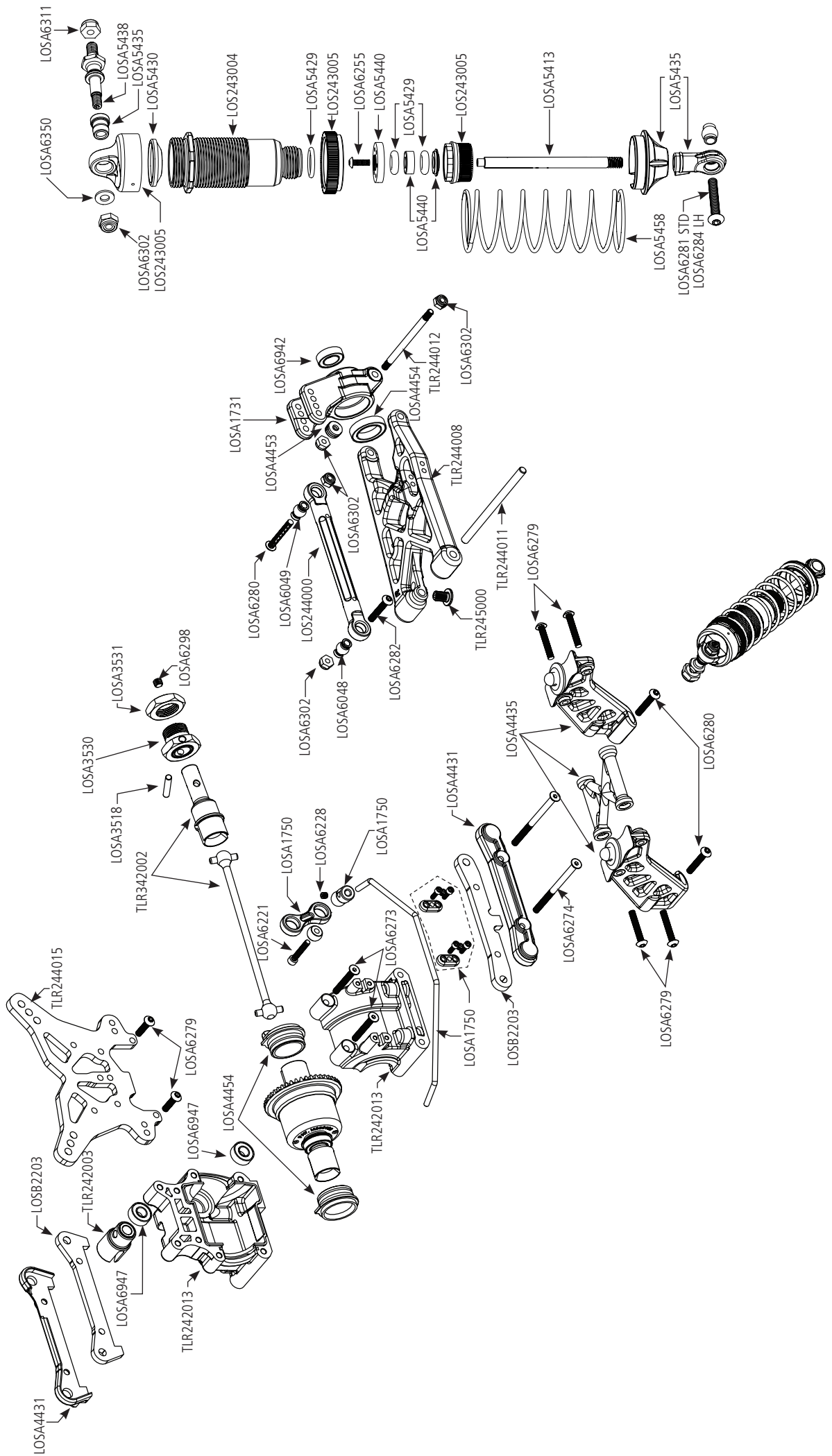

FRONT DIFFERENTIAL
VORDERDIFFERENTIAL
DIFFÉRENTIEL AVANT
DIFFERENZIALE ANTERIORE

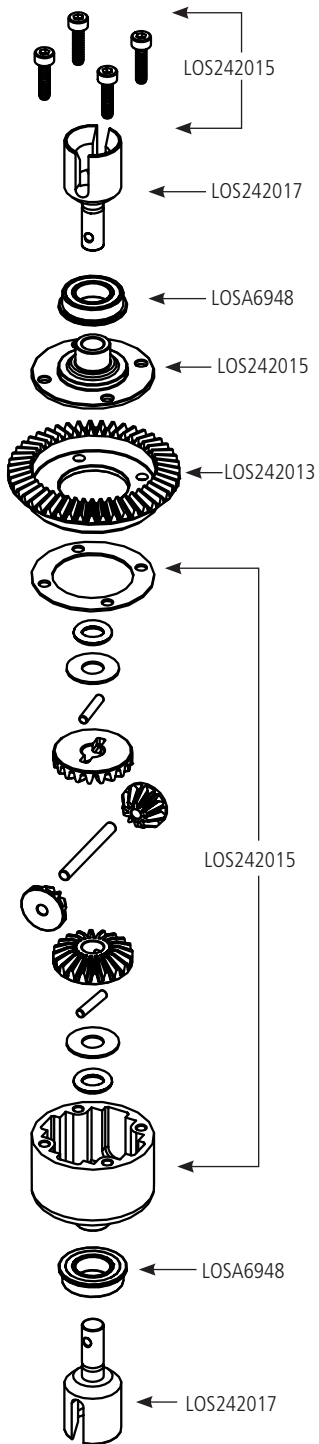

CENTER DIFFERENTIAL
MITTELDIFFERENTIAL
DIFFÉRENTIEL CENTRAL
DIFFERENZIALE CENTRALE

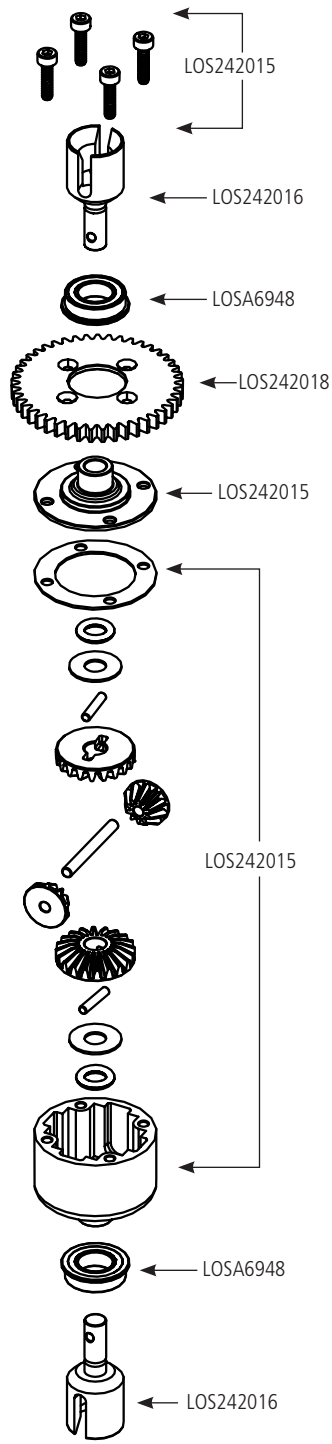

REAR DIFFERENTIAL
HECKDIFFERENTIAL
DIFFÉRENTIEL ARRIERE
DIFFERENZIALE POSTERIORE

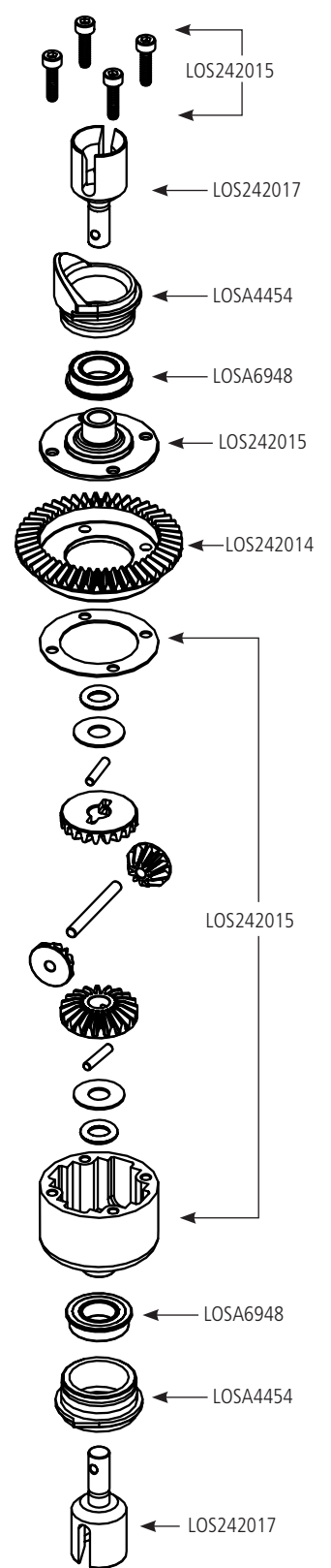



WWW.LOSI.COM

53339.1

Updated 09/2017 LOS04014

©2017 Horizon Hobby LLC.

Losi, 8IGHT-E, DSM, DSMR, Dynamite, Fuze, Reaction, Prophet, Precept, Speedpack, EC5, SpeedTreads and the Horizon Hobby logo are trademarks or registered trademarks of Horizon Hobby, LLC. The Spektrum trademark is used with permission of Bachmann Industries, Inc. All other trademarks, service marks and logos are property of their respective owners. Patents pending.