

Name: _____	Date: _____ Event: _____
City: _____ State: _____	Track: _____
Track Conditions: <input type="checkbox"/> Indoor <input type="checkbox"/> Tight <input type="checkbox"/> Smooth <input type="checkbox"/> Hard Packed <input type="checkbox"/> Blue Groove <input type="checkbox"/> Wet <input type="checkbox"/> Low Bite <input type="checkbox"/> High Bite <input type="checkbox"/> Outdoor <input type="checkbox"/> Open <input type="checkbox"/> Rough <input type="checkbox"/> Loose/Loamy <input type="checkbox"/> Dry <input type="checkbox"/> Dusty <input type="checkbox"/> Med Bite <input type="checkbox"/> Other _____	

Front Suspension

Toe: _____

Ride Height: _____

Camber: _____

Caster Block: 17.5 20

Spindle Height: High Low

Wheel Hex: _____

Sway Bar: _____

Piston/Oil: _____

Shock Type: Bladder Emulsion Vented

Spring: _____

Pills: A _____ B _____

Overall Shock Length: _____

Drag Link/Ackerman: _____

Bump Spindle: _____ Link: _____

Camber Link: _____

Shock Location: _____

Receiver Battery Type: _____

Weight: _____

Differentials

Front: Standard Smart

Spring Wire Dia. _____

Qty of Springs: _____

Ramp Plate: _____

Grease: _____

Diff Fluid: _____

Center: Standard Smart

Spring Wire Dia.: _____

Qty of Springs: _____

Ramp Plate: _____

Grease: _____

Diff Fluid: _____

Drive Shaft

Front: CVA UNI

Rear: CVA UNI

Arm Inserts

Front: None Plastic Carbon

Rear: None Plastic Carbon

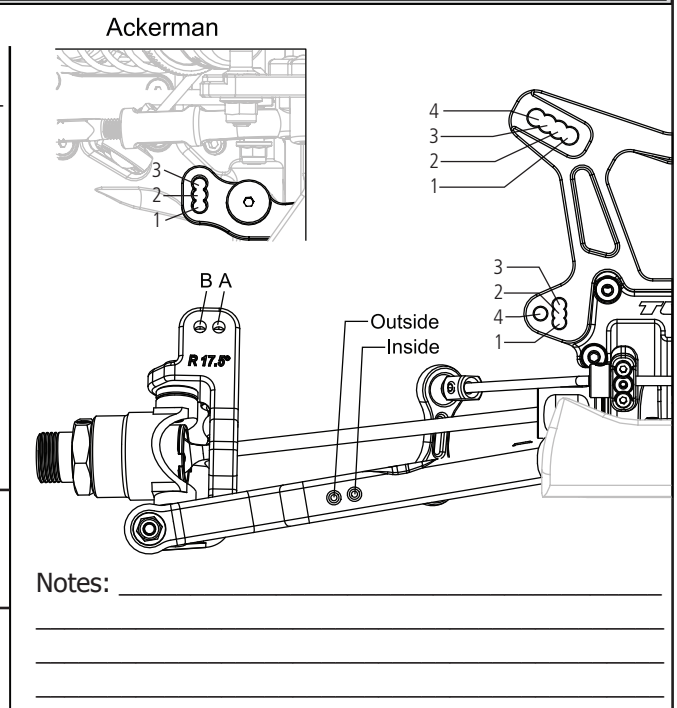

Rear Suspension

Shocks: FWD Back Shock Shaft: 3.5 4.0

Toe/D Pill: _____

Anti-Squat/C Pill: _____

Ride Height: _____

Camber: _____

Rear Hub Spacing: _____

Hub Height: A B Other

Wheel Hex: _____

Sway Bar: _____

Piston/Oil: _____

Shock Type: Bladder Emulsion Vented

Spring: _____

Stroke: _____

Overall Shock Length: _____

Camber Link: _____

Shock Position: _____

Rear Diff Fluid: _____

Weight: _____

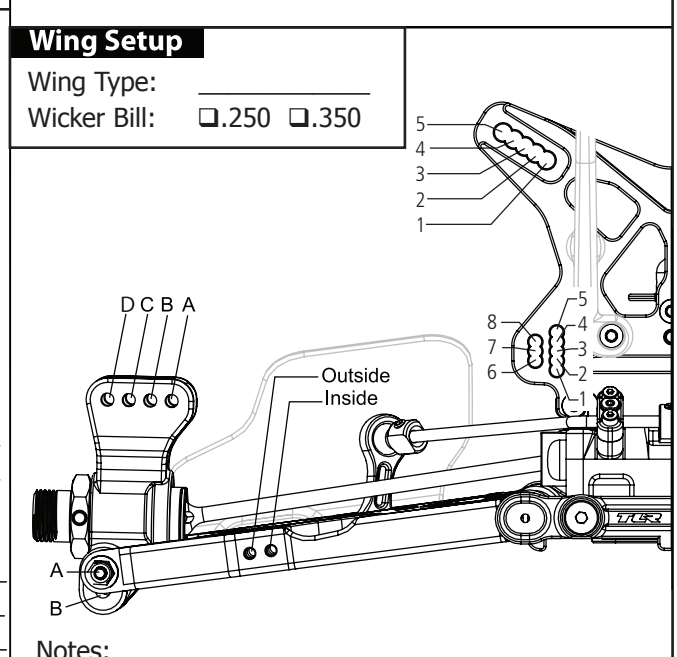

Engine

Engine: _____ Fuel: _____

Glow Plug: _____ Head Clearance _____

Pipe/Header: _____ Gearing: _____

Clutch

Clutch Shoes and Springs Info

Tires

Type	Compound	Insert
Front: _____	_____	_____
Rear: _____	_____	_____
Notes: _____	_____	_____